

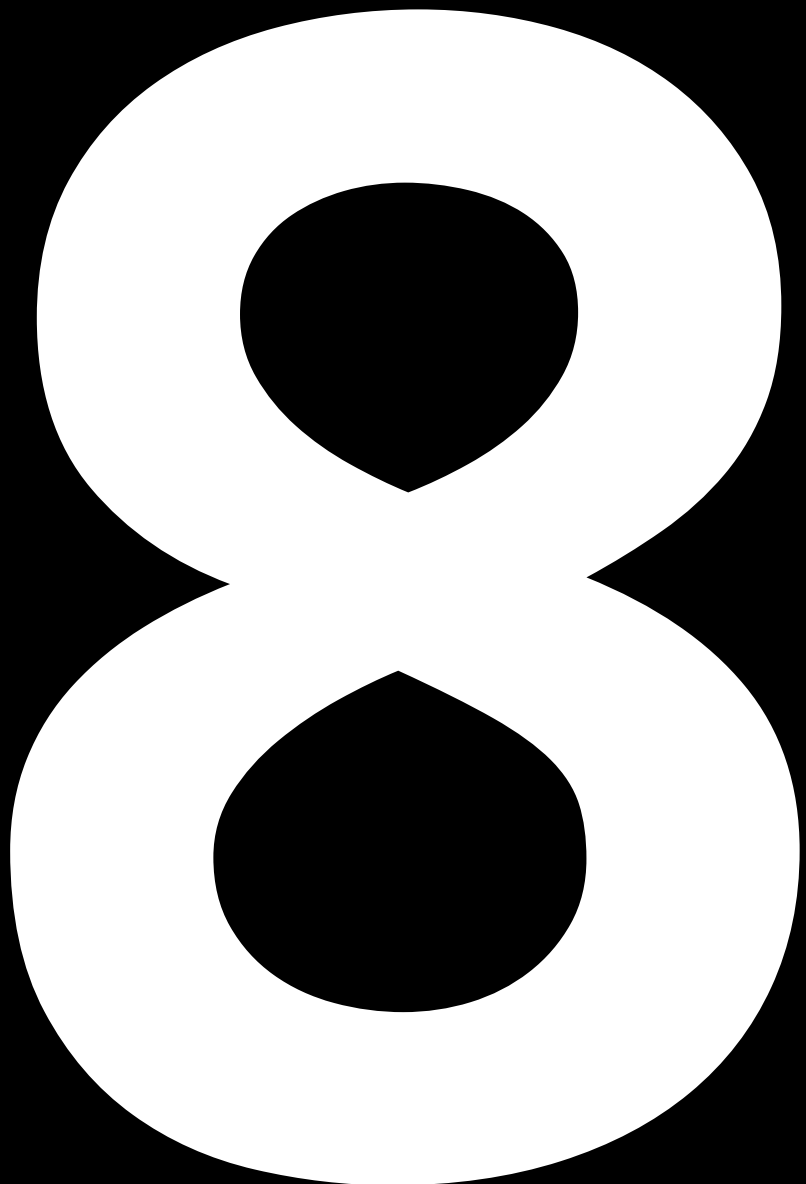

Pegasus
hydraulics

24° compression fittings to
ISO 8434-1 / DIN 2353



































	Product Groups	Page
	Straight coupling	8.05
	Straight reducing coupling	
	LL and L series	8.06
	S series	8.07
	Equal elbow	8.08
	Equal tee	8.09
	Reducing branch tee	
	S series	8.10
	L series	8.11
	Equal cross	8.12
	Bulkhead coupling	8.13
	Bulkhead elbow	8.14
	Male stud coupling to BSP parallel	
	L series	8.15
	Male stud coupling to BSP parallel – captive seal	
	L series	8.16
	Male stud coupling to BSP parallel	
	S series	8.17









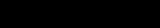

	Product Groups	Page
	Male stud coupling to BSP parallel – captive seal	
	S series	8.18
	Male stud coupling to metric parallel	
	L series	8.19
	S series	8.20
	Male stud coupling to metric parallel – captive seal	
	LL and L series	8.21
	S series	8.22
	Male stud coupling to NPT	
	LL and L series	8.23
	S series	8.24
	Male stud coupling to BSP taper	
	LL and L series	8.25
	S series	8.26
	Male stud coupling to metric taper	
	LL and L series	8.27
	Male stud coupling to UNF	
	L series	8.28
	S series	8.29
	Male stud elbow to BSP taper	
	LL and L series	8.30
	S series	8.31
	Male stud elbow to BSP parallel	8.32
	Male stud elbow to metric taper	8.33

	Product Groups	Page
	Male stud elbow to metric parallel	8.34
	Male stud elbow to NPT LL and L series	8.35
	S series	8.36
	Male stud branch tee to BSP taper	8.37
	Male stud branch tee to BSP parallel	8.38
	Male stud branch tee to metric taper	8.39
	Male stud branch tee to metric parallel	8.40
	Male stud branch tee to NPT	8.41
	Male stud run tee to BSP taper	8.42
	Male stud run tee to BSP parallel	8.43
	Male stud run tee to metric taper	8.44

	Product Groups	Page
	Male stud run tee to metric parallel	8.45
	Male stud run tee to NPT	8.46
	Standpipe to BSP parallel male – body only	8.47
	Adjustable standpipe to BSP parallel male	8.48
	Standpipe to NPT male – body only	8.49
	Adjustable standpipe to NPT male	8.50
	Standpipe to metric parallel male – body only	8.51
	Adjustable standpipe to metric parallel male	8.52
	BSP parallel female pressure gauge connector	8.53
	NPT female pressure gauge connector	8.54

	Product Groups	Page
	Adjustable BSP parallel female pressure gauge connector	
	Assembled	8.55
	Plain standpipe	8.56
	Female stud coupling	
	Female stud coupling to BSP parallel	8.57
	Female stud coupling to metric parallel	8.58
	Female stud coupling to NPT	8.59
	Banjo elbow	
	BSP parallel	8.60
	BSP parallel (ISO 1179 tight access)	8.61
	Metric parallel	8.62
	Banjo tee	
	BSP parallel	8.64
	BSP parallel (ISO 1179 tight access)	8.65
	Adjustable elbow	
	Adjustable male stud elbow to integrated BSP parallel	8.68
	Adjustable standpipe elbow	8.69
	Adjustable elbow	
	Adjustable standpipe elbow with BSP parallel male stud body	8.70
	Adjustable standpipe elbow with metric parallel male stud body	8.71
	Adjustable standpipe branch tee	8.72
	Adjustable standpipe branch tee with BSP parallel male stud body	8.73

	Product Groups	Page
	Adjustable standpipe branch tee with metric parallel male stud body	8.74
	Adjustable standpipe run tee	8.75
	Adjustable standpipe run tee with BSP parallel male stud body	8.76
	Adjustable standpipe run tee with metric parallel male stud body	8.77
	Non-return valve	
	BSP parallel and NPT female	8.84
	Non-return valve	
	Compression to metric parallel male – flow towards thread	8.85
	Compression to BSP parallel male – flow towards thread	8.86
	Non-return valve	
	Compression to metric parallel male – flow away from thread	8.87
	Compression to BSP parallel male – flow away from thread	8.88
	Non-return valve	
	Compression both ends	8.89
	Adjustable standpipe reducer	
	S series	8.90
	L series	8.91
	Hexagonal reducing bush – BSP parallel	
	Form A	8.92
	Hexagonal reducing bush – BSP parallel	
	Form B	8.93
	Hexagonal reducing bush – BSP parallel – with captive seal	
	Form A	8.94

	Product Groups	Page
	Hexagonal reducing bush – BSP parallel – with captive seal Form B	8.95
	Blanking end	8.96
	Blanking plug	8.97
	Threaded Allen key port plug BSP and metric parallel	8.98
	Tube reinforcing ring	8.99
	Locknut	8.100
	Internal coupling nut	8.101
	PTFE sealing ring for banjo fittings	8.102
	Bonded seal	8.103
	Viton sealing ring for banjo fittings	8.104

	Product Groups	Page
	Stainless external sealing ring	8.105
	Stainless internal sealing rings for pressure gauges	8.106
	Viton elastomeric soft seal	8.107
	SAE flange seal	8.108
	Double bite compression cutting ring – “Olive”	8.109
	Double bite compression cutting ring – with Viton soft seal	8.110
	Nut	8.111

Straight coupling

BOOK INDEX

SECTION INDEX

to ISO 8434-1 / DIN 2353

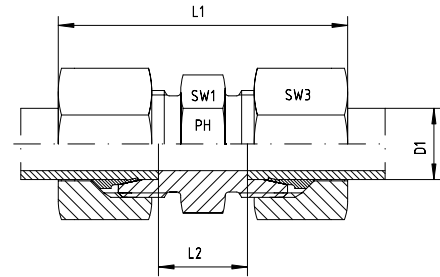

Series	Pressure PN	Tube O.D. D1	Approx. Dimensions				Part code
			L1	L2	SW1	SW3	
LL	100	4	35.0	12	9	10	GV-LL-04
LL	100	6	36.0	9	11	12	GV-LL-06
LL	100	8	38.5	12	12	14	GV-LL-08

Series	Pressure PN	Tube O.D. D1	Approx. Dimensions				Part code
			L1	L2	SW1	SW3	
L	500	6	44.0	10	12	14	GV-L-06
L	500	8	45.0	11	14	17	GV-L-08
L	500	10	48.0	13	17	19	GV-L-10
L	400	12	49.0	14	19	22	GV-L-12
L	400	15	54.0	16	24	27	GV-L-15
L	400	18	56.0	16	27	32	GV-L-18
L	250	22	63.0	20	32	36	GV-L-22
L	250	28	65.0	21	41	41	GV-L-28
L	250	35	74.0	20	46	50	GV-L-35
L	250	42	75.0	21	55	60	GV-L-42

Series	Pressure PN	Tube O.D. D1	Approx. Dimensions				Part code
			L1	L2	SW1	SW3	
S	800	6	50.0	16	14	17	GV-S-06
S	800	8	52.0	18	17	19	GV-S-08
S	800	10	54.0	17	19	22	GV-S-10
S	630	12	57.0	19	22	24	GV-S-12
S	630	14	63.0	22	24	27	GV-S-14
S	630	16	65.0	21	27	30	GV-S-16
S	420	20	73.0	23	32	36	GV-S-20
S	420	25	84.0	26	41	46	GV-S-25
S	420	30	88.0	27	46	50	GV-S-30
S	420	38	99.0	29	55	60	GV-S-38

Fittings can be supplied with nuts with silver-plated threads to help to prevent galling, or can be supplied body only - no nut or cutting ring.

If you require silver-plated nuts, use suffix -SC. If you require body only, use suffix -OMD.

Eg. GV-L-12-SC or, GV-L-12-OMD.

Straight reducing coupling

BOOK INDEX

SECTION INDEX

to ISO 8434-1 / DIN 2353

LL and L series

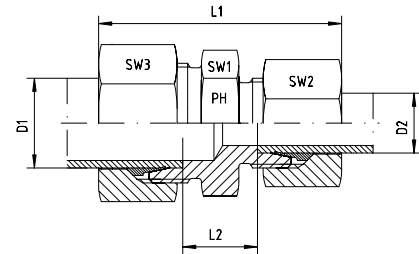

Series	Pressure PN	Tube O.D.		Approx. Dimensions					Part code
		D1	D2	L1	L2	SW1	SW2	SW3	
LL	100	6	4	36.0	10.5	11	10	12	GRV-LL-06/04
LL	100	8	6	38.0	11.0	12	12	14	GRV-LL-08/06

Series	Pressure PN	Tube O.D.		Approx. Dimensions					Part code
		D1	D2	L1	L2	SW1	SW2	SW3	
L	500	8	6	45.5	11.0	14	14	17	GRV-L-08/06
L	500	10	6	47.0	12.0	17	14	19	GRV-L-10/06
L	500	10	8	47.0	12.0	17	17	19	GRV-L-10/08
L	400	12	6	48.0	13.0	19	14	22	GRV-L-12/06
L	400	12	8	48.0	13.0	19	17	22	GRV-L-12/08
L	400	12	10	49.5	14.0	19	19	22	GRV-L-12/10
L	400	15	6	50.5	14.0	24	14	27	GRV-L-15/06
L	400	15	8	50.5	14.0	24	17	27	GRV-L-15/08
L	400	15	10	52.0	15.0	24	19	27	GRV-L-15/10
L	400	15	12	52.0	15.0	24	22	27	GRV-L-15/12
L	400	18	8	52.0	14.5	27	27	32	GRV-L-18/08
L	400	18	10	53.5	15.5	27	19	32	GRV-L-18/10
L	400	18	12	53.5	15.5	27	22	32	GRV-L-18/12
L	400	18	15	56.5	16.5	27	27	32	GRV-L-18/15
L	250	22	8	56.5	17.5	32	17	36	GRV-L-22/08
L	250	22	10	57.0	17.5	32	19	36	GRV-L-22/10
L	250	22	12	57.0	17.5	32	22	36	GRV-L-22/12
L	250	22	15	59.0	18.5	32	27	36	GRV-L-22/15
L	250	22	18	60.0	18.0	32	32	36	GRV-L-22/18
L	250	28	10	60.0	20.5	41	19	41	GRV-L-28/10
L	250	28	12	60.0	19.0	41	22	41	GRV-L-28/12
L	250	28	15	62.5	19.0	41	27	41	GRV-L-28/15
L	250	28	18	61.0	19.0	41	32	41	GRV-L-28/18
L	250	28	22	64.0	21.0	41	36	41	GRV-L-28/22
L	250	35	15			46	27	50	GRV-L-35/15
L	250	35	18	66.5	19.0	46	32	50	GRV-L-35/18
L	250	35	22	69.5	21.0	46	36	50	GRV-L-35/22
L	250	35	28	70.5	21.0	46	41	50	GRV-L-35/28
L	250	42	15	64.0	21.0	55	27	60	GRV-L-42/15
L	250	42	18		20.5	55	32	60	GRV-L-42/18
L	250	42	22	70.5	22.5	55	36	60	GRV-L-42/22
L	250	42	28	71.0	22.5	55	41	60	GRV-L-42/28
L	250	42	35	75.0	21.5	55	50	60	GRV-L-42/35

Fittings can be supplied with nuts with silver-plated threads to help to prevent galling, or can be supplied body only - no nut or cutting ring.

If you require silver-plated nuts, use suffix -SC. If you require body only, use suffix -OMD.

Eg. GRV-L-12/10-SC or, GRV-L-12/10-OMD.

Straight reducing coupling

BOOK INDEX

SECTION INDEX

to ISO 8434-1 / DIN 2353

S series

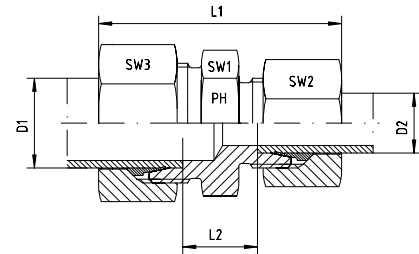

Series	Pressure PN	Tube O.D.		Approx. Dimensions					Part code
		D1	D2	L1	L2	SW1	SW2	SW3	
S	800	8	6	52.5	18.0	17	17	19	GRV-S-08/06
S	800	10	6	53.5	17.5	19	17	22	GRV-S-10/06
S	800	10	8	54.0	17.5	19	19	22	GRV-S-10/08
S	630	12	6	55.5	19.5	22	17	24	GRV-S-12/06
S	630	12	8	55.5	19.5	22	19	24	GRV-S-12/08
S	630	12	10	56.5	19.0	22	22	24	GRV-S-12/10
S	630	14	6			24	17	27	GRV-S-14/06
S	630	14	8			24	19	27	GRV-S-14/08
S	630	14	10	60.0	20.5	24	22	27	GRV-S-14/10
S	630	14	12	60.0	20.5	24	24	27	GRV-S-14/12
S	630	16	6	59.5	20.0	27	17	30	GRV-S-16/06
S	630	16	8	59.5	20.0	27	19	30	GRV-S-16/08
S	630	16	10	60.5	20.0	27	22	30	GRV-S-16/10
S	630	16	12	60.5	20.0	27	24	30	GRV-S-16/12
S	630	16	14	63.5	21.5	27	27	30	GRV-S-16/14
S	420	20	6	64.5	23.5	32	17	36	GRV-S-20/06
S	420	20	8	64.5	21.0	32	19	36	GRV-S-20/08
S	420	20	10	65.5	22.0	32	22	36	GRV-S-20/10
S	420	20	12	65.5	22.0	32	24	36	GRV-S-20/12
S	420	20	14	68.5	23.0	32	27	36	GRV-S-20/14
S	420	20	16	69.5	23.0	32	30	36	GRV-S-20/16
S	420	25	6			41	17	46	GRV-S-25/06
S	420	25	8	71.5	26.5	41	19	46	GRV-S-25/08
S	420	25	10	72.5	27.5	41	22	46	GRV-S-25/10
S	420	25	12	72.5	24.0	41	24	46	GRV-S-25/12
S	420	25	14	74.5	26.5	41	27	46	GRV-S-25/14
S	420	25	16	74.5	25.5	41	30	46	GRV-S-25/16
S	420	25	20	79.0	25.5	41	36	46	GRV-S-25/20
S	420	30	10	74.5	25.0	46	22	50	GRV-S-30/10
S	420	30	12	74.5	27.0	46	24	50	GRV-S-30/12
S	420	30	14			46	27	50	GRV-S-30/14
S	420	30	16	78.5	26.0	46	30	50	GRV-S-30/16
S	420	30	20	81.5	26.0	46	36	50	GRV-S-30/20
S	420	30	25	86.0	26.5	46	46	50	GRV-S-30/25
S	420	38	10	75.5	24.5	55	22	60	GRV-S-38/10
S	420	38	12			55	24	60	GRV-S-38/12
S	420	38	14			55	27	60	GRV-S-38/14
S	420	38	16	85.0	26.0	55	30	60	GRV-S-38/16
S	420	38	20	88.0	28.0	55	36	60	GRV-S-38/20
S	420	38	25	94.0	29.0	55	46	60	GRV-S-38/25
S	420	38	30	95.5	29.5	55	50	60	GRV-S-38/30

Fittings can be supplied with nuts with silver-plated threads to help to prevent galling, or can be supplied body only - no nut or cutting ring.

If you require silver-plated nuts, use suffix -SC. If you require body only, use suffix -OMD.

Eg. GRV-S-12/10-SC or, GRV-S-12/10-OMD.

Equal elbow

BOOK INDEX

SECTION INDEX

to ISO 8434-1 / DIN 2353

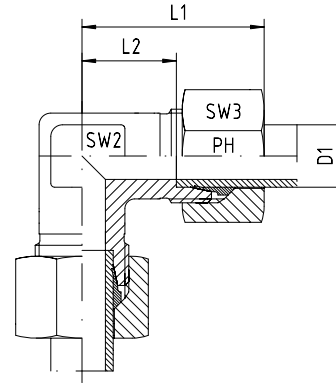

Series	Pressure PN	Tube O.D. D1	Approx. Dimensions				Part code
			L1	L2	SW2	SW3	
LL	100	4	21	11.0	9	10	WV-LL-04
LL	100	6	21	9.5	9	12	WV-LL-06
LL	100	8	23	11.5	12	14	WV-LL-08

Series	Pressure PN	Tube O.D. D1	Approx. Dimensions				Part code
			L1	L2	SW2	SW3	
L	500	6	27	12.0	12	14	WV-L-06
L	500	8	29	14.0	12	17	WV-L-08
L	500	10	30	15.0	14	19	WV-L-10
L	400	12	32	17.0	17	22	WV-L-12
L	400	15	36	21.0	19	27	WV-L-15
L	400	18	40	23.5	24	32	WV-L-18
L	250	22	44	27.5	27	36	WV-L-22
L	250	28	47	30.5	36	41	WV-L-28
L	250	35	56	34.5	41	50	WV-L-35
L	250	42	63	40.0	50	60	WV-L-42

Series	Pressure PN	Tube O.D. D1	Approx. Dimensions				Part code
			L1	L2	SW2	SW3	
S	800	6	31	16.0	12	17	WV-S-06
S	800	8	32	17.0	14	19	WV-S-08
S	800	10	34	17.5	17	22	WV-S-10
S	630	12	38	21.5	17	24	WV-S-12
S	630	14	40	22.0	19	27	WV-S-14
S	630	16	43	24.5	24	30	WV-S-16
S	420	20	48	26.5	27	36	WV-S-20
S	420	25	54	30.0	36	46	WV-S-25
S	420	30	62	35.5	41	50	WV-S-30
S	420	38	72	41.0	50	60	WV-S-38

Fittings can be supplied with nuts with silver-plated threads to help to prevent galling, or can be supplied body only - no nut or cutting ring.

If you require silver-plated nuts, use suffix -SC. If you require body only, use suffix -OMD.

Eg. WV-L-12-SC or, WV-L-12-OMD.

Equal tee

BOOK INDEX

SECTION INDEX

to ISO 8434-1 / DIN 2353

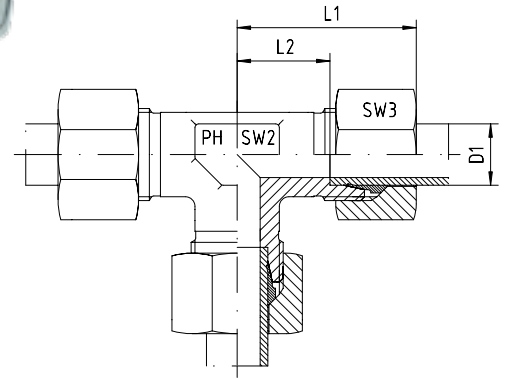

Series	Pressure PN	Tube O.D. D1	Approx. Dimensions				Part code
			L1	L2	SW2	SW3	
LL	100	4	21	11.0	9	10	TV-LL-04
LL	100	6	21	9.5	9	12	TV-LL-06
LL	100	8	23	11.5	12	14	TV-LL-08

Series	Pressure PN	Tube O.D. D1	Approx. Dimensions				Part code
			L1	L2	SW2	SW3	
L	500	6	27	12.0	12	14	TV-L-06
L	500	8	29	14.0	12	17	TV-L-08
L	500	10	30	15.0	14	19	TV-L-10
L	400	12	32	17.0	17	22	TV-L-12
L	400	15	36	21.0	19	27	TV-L-15
L	400	18	40	23.5	24	32	TV-L-18
L	250	22	44	27.5	27	36	TV-L-22
L	250	28	47	30.5	36	41	TV-L-28
L	250	35	56	34.5	41	50	TV-L-35
L	250	42	63	40.0	50	60	TV-L-42

Series	Pressure PN	Tube O.D. D1	Approx. Dimensions				Part code
			L1	L2	SW2	SW3	
S	800	6	31	16.0	12	17	TV-S-06
S	800	8	32	17.0	14	19	TV-S-08
S	800	10	34	17.5	17	22	TV-S-10
S	630	12	38	21.5	17	24	TV-S-12
S	630	14	40	22.0	19	27	TV-S-14
S	630	16	43	24.4	24	30	TV-S-16
S	420	20	48	26.5	27	36	TV-S-20
S	420	25	54	30.0	36	46	TV-S-25
S	420	30	62	35.5	41	50	TV-S-30
S	420	38	72	41.0	50	60	TV-S-38

Fittings can be supplied with nuts with silver-plated threads to help to prevent galling, or can be supplied body only - no nut or cutting ring.

If you require silver-plated nuts, use suffix -SC. If you require body only, use suffix -OMD.

Eg. TV-L-12-SC or, TV-L-12-OMD.

Reducing branch tee

BOOK INDEX

SECTION INDEX

to ISO 8434-1 / DIN 2353

S series

Other reducing sizes
available upon request

The branch is the middle
size in the code

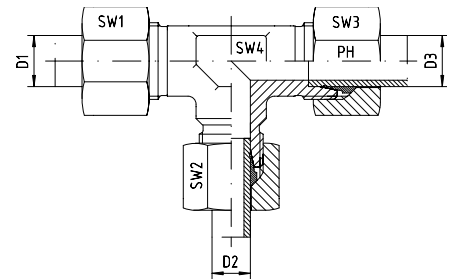

Series	Pressure PN	Tube O.D.			Approx. Dimensions				Part code
		D1	D2	D3	SW1	SW2	SW3	SW4	
S	800	8	6	8	19	17	19	14	TRV-S-08/06/08
S	800	10	6	10	22	17	22	17	TRV-S-10/06/10
S	800	10	8	10	22	19	22	17	TRV-S-10/08/10
S	630	12	6	12	24	17	24	17	TRV-S-12/06/12
S	630	12	8	8	24	19	19	17	TRV-S-12/08/08
S	630	12	8	12	24	19	24	17	TRV-S-12/08/12
S	630	12	10	12	24	22	24	17	TRV-S-12/10/12
S	630	12	16	12	24	30	24	24	TRV-S-12/16/12
S	630	14	8	14	27	19	27	19	TRV-S-14/08/14
S	630	14	10	14	27	22	27	19	TRV-S-14/10/14
S	630	16	6	16	30	17	30	24	TRV-S-16/06/16
S	630	16	8	16	30	19	30	24	TRV-S-16/08/16
S	630	16	10	16	30	22	30	24	TRV-S-16/10/16
S	630	16	12	12	30	24	24	24	TRV-S-16/12/12
S	630	16	12	16	30	24	30	24	TRV-S-16/12/16
S	630	16	14	16	30	27	30	24	TRV-S-16/14/16
S	420	16	20	16	30	36	30	27	TRV-S-16/20/16
S	420	20	8	20	36	19	36	27	TRV-S-20/08/20
S	420	20	10	20	36	22	36	27	TRV-S-20/10/20
S	420	20	12	20	36	24	36	27	TRV-S-20/12/20
S	420	20	14	20	36	27	36	27	TRV-S-20/14/20
S	420	20	16	20	36	30	36	27	TRV-S-20/16/20
S	420	20	25	20	36	46	36	36	TRV-S-20/25/20
S	420	25	10	25	46	22	46	36	TRV-S-25/10/25
S	420	25	12	25	46	24	46	36	TRV-S-25/12/25
S	420	25	14	25	46	27	46	36	TRV-S-25/14/25
S	420	25	16	25	46	30	46	36	TRV-S-25/16/25
S	420	25	20	25	46	36	46	36	TRV-S-25/20/25
S	420	25	30	25	46	50	46	41	TRV-S-25/30/25
S	420	30	12	30	50	24	50	41	TRV-S-30/12/30
S	420	30	16	30	50	30	40	41	TRV-S-30/16/30
S	420	30	20	30	50	36	50	41	TRV-S-30/20/30
S	420	30	25	30	50	46	50	41	TRV-S-30/25/30
S	420	30	38	30	50	60	50	50	TRV-S-30/38/30
S	420	38	16	38	60	30	60	50	TRV-S-38/16/38
S	420	38	20	38	60	36	60	50	TRV-S-38/20/38
S	420	38	25	38	60	46	60	50	TRV-S-38/25/38
S	420	38	30	38	60	50	60	50	TRV-S-38/30/38

Reducing branch tee

BOOK INDEX

SECTION INDEX

to ISO 8434-1 / DIN 2353

L series

Other reducing sizes available upon request

The branch is the middle size in the code

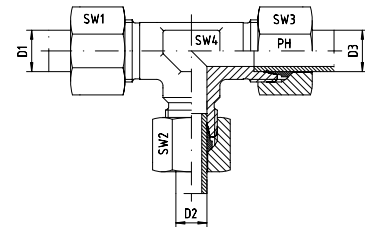

Series	Pressure PN	Tube O.D.			Approx. Dimensions				Part code
		D1	D2	D3	SW1	SW2	SW3	SW4	
L	500	6	8	6	14	17	14	14	TRV-L-06/08/06
L	500	6	10	6	14	19	14	17	TRV-L-06/10/06
L	500	8	6	8	17	14	17	14	TRV-L-08/06/08
L	500	8	10	8	17	19	17	17	TRV-L-08/10/08
L	400	8	12	8	17	22	17	17	TRV-L-08/12/08
L	500	10	6	10	19	14	19	17	TRV-L-10/06/10
L	500	10	8	10	19	17	19	17	TRV-L-10/08/10
L	500	10	10	6	19	19	14	17	TRV-L-10/10/06
L	400	10	12	10	19	22	19	17	TRV-L-10/12/10
L	400	10	15	10	19	27	19	19	TRV-L-10/15/10
L	400	12	6	12	22	14	22	17	TRV-L-12/06/12
L	400	12	8	8	22	17	17	17	TRV-L-12/08/08
L	400	12	8	12	22	17	22	17	TRV-L-12/08/12
L	400	12	10	10	22	19	19	17	TRV-L-12/10/10
L	400	12	10	12	22	19	22	17	TRV-L-12/10/12
L	400	12	12	10	22	22	19	17	TRV-L-12/12/10
L	400	12	15	12	22	27	22	19	TRV-L-12/15/12
L	400	12	18	12	22	32	22	24	TRV-L-12/18/12
L	400	15	6	15	27	14	27	19	TRV-L-15/06/15
L	400	15	8	15	27	17	27	19	TRV-L-15/08/15
L	400	15	10	15	27	19	27	19	TRV-L-15/10/15
L	400	15	12	12	27	22	22	19	TRV-L-15/12/12
L	400	15	12	15	27	22	27	19	TRV-L-15/12/15
L	400	15	15	12	27	27	22	19	TRV-L-15/15/12
L	250	15	22	15	27	36	27	27	TRV-L-15/22/15
L	400	18	8	18	32	17	32	24	TRV-L-18/08/18
L	400	18	10	10	32	19	19	24	TRV-L-18/10/10
L	400	18	10	18	32	19	32	24	TRV-L-18/10/18
L	400	18	12	18	32	22	32	24	TRV-L-18/12/18
L	400	18	15	18	32	27	32	24	TRV-L-18/15/18
L	400	18	18	10	32	32	19	24	TRV-L-18/18/10
L	250	22	10	22	36	19	36	27	TRV-L-22/10/22
L	250	22	12	22	36	22	36	27	TRV-L-22/12/22
L	250	22	15	15	36	27	27	27	TRV-L-22/15/15
L	250	22	15	22	36	27	36	27	TRV-L-22/15/22
L	250	22	18	18	36	32	32	27	TRV-L-22/18/18
L	250	22	18	22	36	32	36	27	TRV-L-22/18/22
L	250	22	22	18	36	36	32	27	TRV-L-22/22/18
L	250	28	10	28	41	19	41	36	TRV-L-28/10/28
L	250	28	12	28	41	22	41	36	TRV-L-28/12/28
L	250	28	15	28	41	27	41	36	TRV-L-28/15/28
L	250	28	18	28	41	32	41	36	TRV-L-28/18/28
L	250	28	22	22	41	36	36	36	TRV-L-28/22/22
L	250	28	22	28	41	36	41	36	TRV-L-28/22/28
L	250	28	35	28	41	50	41	41	TRV-L-28/35/28
L	250	35	12	35	50	22	50	41	TRV-L-35/12/35
L	250	35	15	35	50	27	50	41	TRV-L-35/15/35
L	250	35	18	35	50	32	50	41	TRV-L-35/18/35
L	250	35	22	35	50	36	50	41	TRV-L-35/22/35
L	250	35	28	35	50	41	50	41	TRV-L-35/28/35
L	250	35	42	35	50	60	50	50	TRV-L-35/42/35
L	250	42	15	42	60	27	60	50	TRV-L-42/15/42
L	250	42	18	42	60	32	60	50	TRV-L-42/18/42
L	250	42	22	42	60	36	60	50	TRV-L-42/22/42
L	250	42	28	42	60	41	60	50	TRV-L-42/28/42
L	250	42	35	42	60	50	60	50	TRV-L-42/35/42

Equal cross

BOOK INDEX

SECTION INDEX

to ISO 8434-1 / DIN 2353

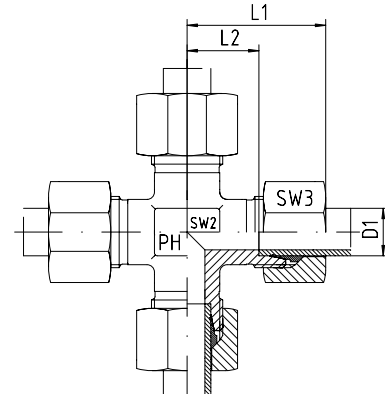

Series	Pressure PN	Tube O.D. D1	Approx. Dimensions				Part code
			L1	L2	SW2	SW3	
LL	100	4	21	11.0	7	10	KV-LL-04
LL	100	6	21	9.5	9	12	KV-LL-06
LL	100	8	23	11.5	12	14	KV-LL-08

Series	Pressure PN	Tube O.D. D1	Approx. Dimensions				Part code
			L1	L2	SW2	SW3	
L	315	6	27	12.0	12	14	KV-L-06
L	315	8	29	14.0	12	17	KV-L-08
L	315	10	30	15.0	14	19	KV-L-10
L	315	12	32	17.0	17	22	KV-L-12
L	315	15	36	21.0	19	27	KV-L-15
L	315	18	40	23.5	24	32	KV-L-18
L	160	22	44	27.5	27	36	KV-L-22
L	160	28	47	30.5	36	41	KV-L-28
L	160	35	56	34.5	41	50	KV-L-35
L	160	42	63	40.0	50	60	KV-L-42

Series	Pressure PN	Tube O.D. D1	Approx. Dimensions				Part code
			L1	L2	SW2	SW3	
S	630	6	31	16.0	12	17	KV-S-06
S	630	8	32	17.0	14	19	KV-S-08
S	630	10	34	17.5	17	22	KV-S-10
S	630	12	38	21.5	17	24	KV-S-12
S	630	14	40	22.0	19	27	KV-S-14
S	400	16	43	24.5	24	30	KV-S-16
S	400	20	48	26.5	27	36	KV-S-20
S	400	25	54	30.0	36	46	KV-S-25
S	400	30	62	35.5	41	50	KV-S-30
S	315	38	72	41.0	50	60	KV-S-38

Fittings can be supplied with nuts with silver-plated threads to help to prevent galling, or can be supplied body only - no nut or cutting ring.

If you require silver-plated nuts, use suffix -SC. If you require body only, use suffix -OMD.

Eg. KV-L-12-SC, or KV-L-12-OMD.

Bulkhead coupling

BOOK INDEX

SECTION INDEX

to ISO 8434-1 / DIN 2353

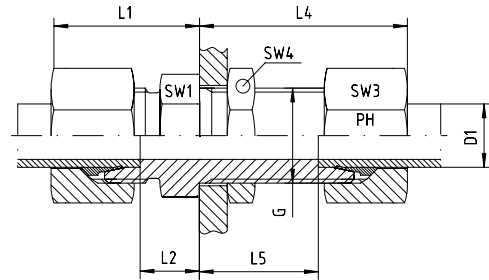
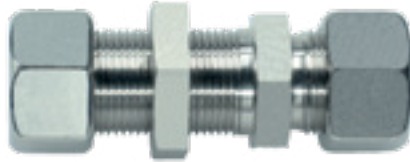

Series	Pressure PN	Tube O.D. D1	Thread G	Approx. Dimensions							Part code
				L1	L2	L4	L5	SW1	SW3	SW4	
LL	100	4	M 8 x 1	19	7.0	23	11.0	11	10	11	GSV-LL-04
LL	100	6	M 10 x 1								GSV-LL-06
LL	100	8	M 12 x 1								GSV-LL-08

Series	Pressure PN	Tube O.D. D1	Thread G	Approx. Dimensions							Part code
				L1	L2	L4	L5	SW1	SW3	SW4	
L	500	6	M 12 x 1.5	22	7.0	42	27.0	17	14	17	GSV-L-06
L	500	8	M 14 x 1.5	23	8.0	42	27.0	19	17	19	GSV-L-08
L	500	10	M 16 x 1.5	25	10.0	43	28.0	22	19	22	GSV-L-10
L	400	12	M 18 x 1.5	25	10.0	44	29.0	24	22	24	GSV-L-12
L	400	15	M 22 x 1.5	27	12.0	46	31.0	27	27	30	GSV-L-15
L	400	18	M 26 x 1.5	30	13.5	49	32.5	32	32	36	GSV-L-18
L	250	22	M 30 x 2	33	16.5	51	34.5	36	36	41	GSV-L-22
L	250	28	M 36 x 2	35	18.5	52	35.5	41	41	46	GSV-L-28
L	250	35	M 45 x 2	40	18.5	58	36.5	50	50	55	GSV-L-35
L	250	42	M 52 x 2	42	19.0	59	36.0	60	60	65	GSV-L-42

Series	Pressure PN	Tube O.D. D1	Thread G	Approx. Dimensions							Part code
				L1	L2	L4	L5	SW1	SW3	SW4	
S	800	6	M 14 x 1.5	27	12.0	44	29.0	19	17	19	GSV-S-06
S	800	8	M 16 x 1.5	28	13.0	44	29.0	22	19	22	GSV-S-08
S	800	10	M 18 x 1.5	31	14.5	46	29.5	24	22	24	GSV-S-10
S	630	12	M 20 x 1.5	31	14.5	47	30.5	27	24	27	GSV-S-12
S	630	14	M 22 x 1.5	35	17.0	50	32.0	30	27	30	GSV-S-14
S	630	16	M 24 x 1.5	35	16.5	50	31.5	32	30	32	GSV-S-16
S	420	20	M 30 x 2	39	17.5	55	33.5	41	36	41	GSV-S-20
S	420	25	M 36 x 2	44	20.0	59	35.0	46	46	46	GSV-S-25
S	420	30	M 42 x 2	48	21.5	64	37.5	50	50	50	GSV-S-30
S	420	38	M 52 x 2	53	22.0	68	37.0	65	60	65	GSV-S-38

Fittings can be supplied with nuts with silver-plated threads to help to prevent galling, or can be supplied body only - no nut or cutting ring.

If you require silver-plated nuts, use suffix -SC. If you require body only, use suffix -OMD.

Eg. GSV-L-12-SC, or GSV-L-12-OMD.

Bulkhead elbow

BOOK INDEX

SECTION INDEX

to ISO 8434-1 / DIN 2353

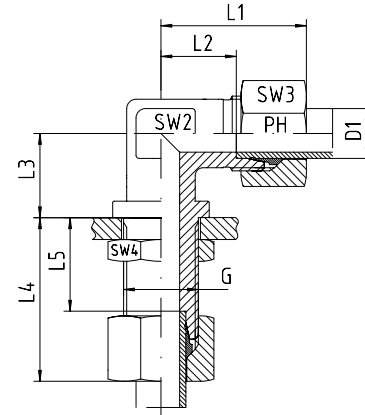

Series	Pressure PN	Tube O.D. D1	Thread G	Approx. Dimensions								Part code
				L1	L2	L3	L4	L5	SW2	SW3	SW4	
L	315	6	M 12 x 1.5	27	12.0	14	42	27.0	12	14	17	WSV-L-06
L	315	8	M 14 x 1.5	29	14.0	17	42	27.0	12	17	19	WSV-L-08
L	315	10	M 16 x 1.5	30	15.0	18	43	28.0	14	19	22	WSV-L-10
L	315	12	M 18 x 1.5	32	17.0	20	44	29.0	17	22	24	WSV-L-12
L	315	15	M 22 x 1.5	36	21.0	23	46	31.0	19	27	30	WSV-L-15
L	315	18	M 26 x 1.5	40	23.5	24	49	32.5	24	32	36	WSV-L-18
L	160	22	M 30 x 2	44	27.5	30	51	34.5	27	36	41	WSV-L-22
L	160	28	M 36 x 2	47	30.5	34	52	35.5	36	41	46	WSV-L-28
L	160	35	M 45 x 2	56	34.5	39	58	36.5	41	50	55	WSV-L-35
L	160	42	M 52 x 2	63	40.0	43	59	36.0	50	60	65	WSV-L-42

Series	Pressure PN	Tube O.D. D1	Thread G	Approx. Dimensions								Part code
				L1	L2	L3	L4	L5	SW2	SW3	SW4	
S	630	6	M 14 x 1.5	31	16.0	17	44	29.0	12	17	19	WSV-S-06
S	630	8	M 16 x 1.5	32	17.0	18	44	29.0	14	19	22	WSV-S-08
S	630	10	M 18 x 1.5	34	17.5	20	46	29.5	17	22	24	WSV-S-10
S	630	12	M 20 x 1.5	38	21.5	21	47	30.5	17	24	27	WSV-S-12
S	630	14	M 22 x 1.5	40	22.0	23	50	32.0	19	27	30	WSV-S-14
S	400	16	M 24 x 1.5	43	24.5	24	50	31.5	24	30	32	WSV-S-16
S	400	20	M 30 x 2	48	26.5	30	55	33.5	27	36	41	WSV-S-20
S	400	25	M 36 x 2	54	30.0	34	59	35.0	36	46	46	WSV-S-25
S	400	30	M 42 x 2	62	35.5	39	64	37.5	41	50	50	WSV-S-30
S	315	38	M 52 x 2	72	41.0	43	68	37.0	50	60	65	WSV-S-38

Fittings can be supplied with nuts with silver-plated threads to help to prevent galling, or can be supplied body only - no nut or cutting ring.

If you require silver-plated nuts, use suffix -SC. If you require body only, use suffix -OMD.

Eg. WSV-L-12-SC, or WSV-L-12-OMD.

Male stud coupling to BSP parallel

BOOK INDEX

SECTION INDEX

to ISO 8434-1 / DIN 2353

LL and L series

Form B sealing shoulder

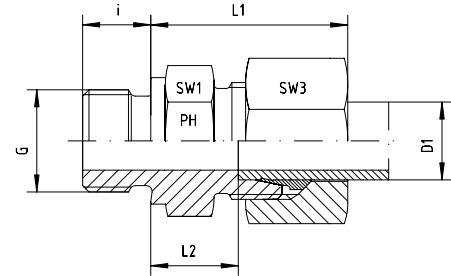
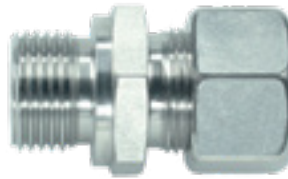

Series	Pressure PN	Tube O.D. D1	Thread G	Approx. Dimensions					Part code
				L1	L2	i	SW1	SW3	
LL	100	4	G 1/8"	19.0	9.5	8	14	10	GE-LLR-04-G 1/8"
LL	100	6	G 1/8"	20.0	9.5	8	14	12	GE-LLR-06-G 1/8"
LL	100	8	G 1/8"		9.0	8	14	14	GE-LLR-08-G 1/8"

Series	Pressure PN	Tube O.D. D1	Thread G	Approx. Dimensions					Part code
				L1	L2	i	SW1	SW3	
L	315	6	G 1/8"	23.0	8.5	8	14	14	GE-LR-06-G 1/8"
L	315	6	G 1/4"	27.0	9.0	12	19	14	GE-LR-06-G 1/4"
L	315	6	G 3/8"	27.0	11.5	12	22	14	GE-LR-06-G 3/8"
L	315	6	G 1/2"	29.0	12.0	14	27	14	GE-LR-06-G 1/2"
L	315	8	G 1/8"	26.0	9.5	8	14	17	GE-LR-08-G 1/8"
L	315	8	G 1/4"	25.0	10.0	12	19	17	GE-LR-08-G 1/4"
L	315	8	G 3/8"	28.5	11.5	12	22	17	GE-LR-08-G 3/8"
L	315	8	G 1/2"	28.5	13.0	14	27	17	GE-LR-08-G 1/2"
L	315	10	G 1/8"	27.5	11.0	8	17	19	GE-LR-10-G 1/8"
L	315	10	G 1/4"	26.0	11.0	12	19	19	GE-LR-10-G 1/4"
L	315	10	G 3/8"	30.5	12.5	12	22	19	GE-LR-10-G 3/8"
L	315	10	G 1/2"	32.5	13.0	14	27	19	GE-LR-10-G 1/2"
L	315	10	G 3/4"			16	32	19	GE-LR-10-G 3/4"
L	315	12	G 1/8"	29.0	11.0	8	19	22	GE-LR-12-G 1/8"
L	315	12	G 1/4"	30.0	12.0	12	19	22	GE-LR-12-G 1/4"
L	315	12	G 3/8"	27.0	12.5	12	22	22	GE-LR-12-G 3/8"
L	315	12	G 1/2"	31.0	13.0	14	27	22	GE-LR-12-G 1/2"
L	315	12	G 3/4"	31.0	14.0	16	32	22	GE-LR-12-G 3/4"
L	315	15	G 1/4"	32.0	13.0	12	24	27	GE-LR-15-G 1/4"
L	315	15	G 3/8"	31.0	13.5	12	24	27	GE-LR-15-G 3/8"
L	315	15	G 1/2"	29.0	14.0	14	27	27	GE-LR-15-G 1/2"
L	315	15	G 3/4"	32.5	15.0	16	32	27	GE-LR-15-G 3/4"
L	315	15	G 1"			18	41	27	GE-LR-15-G 1"
L	315	18	G 3/8"	31.0	12.5	12	27	32	GE-LR-18-G 3/8"
L	315	18	G 1/2"	31.0	14.5	14	27	32	GE-LR-18-G 1/2"
L	315	18	G 3/4"	34.0	14.5	16	32	32	GE-LR-18-G 3/4"
L	315	18	G 1"		16.5	18	41	32	GE-LR-18-G 1"
L	160	22	G 3/8"	49.0	16.0	12	32	36	GE-LR-22-G 3/8"
L	160	22	G 1/2"	37.0	16.5	14	32	36	GE-LR-22-G 1/2"
L	160	22	G 3/4"	33.0	16.5	16	32	36	GE-LR-22-G 3/4"
L	160	22	G 1"	38.0	17.5	18	41	36	GE-LR-22-G 1"
L	160	22	G 1 1/4"			20	50	36	GE-LR-22-G 1 1/4"
L	160	28	G 1/2"		17.5	14	41	41	GE-LR-28-G 1/2"
L	160	28	G 3/4"	38.0	17.5	16	41	41	GE-LR-28-G 3/4"
L	160	28	G 1"	34.0	17.5	18	41	41	GE-LR-28-G 1"
L	160	28	G 1 1/4"		18.5	20	50	41	GE-LR-28-G 1 1/4"
L	160	28	G 1 1/2"	43.0	20.5	22	55	41	GE-LR-28-G 1 1/2"
L	160	35	G 3/4"	42.0	18.5	16	46	50	GE-LR-35-G 3/4"
L	160	35	G 1"	42.0	17.5	18	46	50	GE-LR-35-G 1"
L	160	35	G 1 1/4"	39.0	17.5	20	50	50	GE-LR-35-G 1 1/4"
L	160	35	G 1 1/2"	44.0	19.5	22	55	50	GE-LR-35-G 1 1/2"
L	160	42	G 1"	47.0	19.0	18	55	60	GE-LR-42-G 1"
L	160	42	G 1 1/4"	47.0	19.0	20	55	60	GE-LR-42-G 1 1/4"
L	160	42	G 1 1/2"	47.0	19.0	22	55	60	GE-LR-42-G 1 1/2"
L	160	42	G 2"				70	60	GE-LR-42-G 2"



24° compression fittings to ISO 8434-1 / DIN 2353



Male stud coupling to BSP parallel – captive seal

BOOK INDEX

SECTION INDEX

to ISO 8434-1 / DIN 2353

LL and L series

Captive Viton elastomeric
soft seal

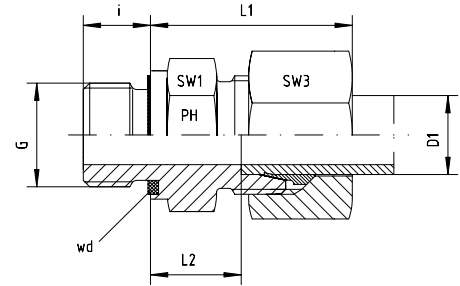
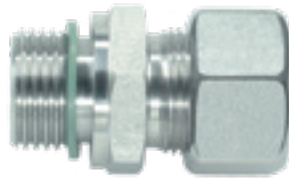

Series	Pressure PN	Tube O.D. D1	Thread G	Approx. Dimensions					Part code
				L1	L2	i	SW1	SW3	
LL	100	4	G 1/8"	19.0	9.5	8	14	10	GE-LLR-04-G 1/8"-wd
LL	100	6	G 1/8"	20.0	9.5	8	14	12	GE-LLR-06-G 1/8"-wd
LL	100	8	G 1/8"		9.0	8	14	14	GE-LLR-08-G 1/8"-wd

Series	Pressure PN	Tube O.D. D1	Thread G	Approx. Dimensions					Part code
				L1	L2	i	SW1	SW3	
L	500	6	G 1/8"	23.0	8.5	8	14	14	GE-LR-06-G 1/8"-wd
L	500	6	G 1/4"	27.0	9.0	12	17	14	GE-LR-06-G 1/4"-wd
L	400	6	G 3/8"	27.0	11.5	12	22	14	GE-LR-06-G 3/8"-wd
L	400	6	G 1/2"	29.0	12.0	14	27	14	GE-LR-06-G 1/2"-wd
L	500	8	G 1/8"	26.0	9.5	8	14	17	GE-LR-08-G 1/8"-wd
L	500	8	G 1/4"	25.0	10.0	12	19	17	GE-LR-08-G 1/4"-wd
L	400	8	G 3/8"	28.5	11.5	12	22	17	GE-LR-08-G 3/8"-wd
L	400	8	G 1/2"	28.5	13.0	14	27	17	GE-LR-08-G 1/2"-wd
L	500	10	G 1/8"	27.5	11.0	8	17	19	GE-LR-10-G 1/8"-wd
L	500	10	G 1/4"	26.0	11.0	12	19	19	GE-LR-10-G 1/4"-wd
L	400	10	G 3/8"	30.5	12.5	12	22	19	GE-LR-10-G 3/8"-wd
L	400	10	G 1/2"	32.5	13.0	14	27	19	GE-LR-10-G 1/2"-wd
L	250	10	G 3/4"		14.0	16	32	19	GE-LR-10-G 3/4"-wd
L	400	12	G 1/8"	29.0	11.0	8	19	22	GE-LR-12-G 1/8"-wd
L	400	12	G 1/4"	30.0	12.0	12	19	22	GE-LR-12-G 1/4"-wd
L	400	12	G 3/8"	27.0	12.5	12	22	22	GE-LR-12-G 3/8"-wd
L	400	12	G 1/2"	31.0	13.0	14	27	22	GE-LR-12-G 1/2"-wd
L	250	12	G 3/4"	31.0	14.0	16	32	22	GE-LR-12-G 3/4"-wd
L	400	15	G 1/4"	32.0	13.0	12	24	27	GE-LR-15-G 1/4"-wd
L	400	15	G 3/8"	31.0	13.5	12	24	27	GE-LR-15-G 3/8"-wd
L	400	15	G 1/2"	29.0	14.0	14	27	27	GE-LR-15-G 1/2"-wd
L	250	15	G 3/4"	32.5	15.0	16	32	27	GE-LR-15-G 3/4"-wd
L	250	15	G 1"		16.0	18	41	27	GE-LR-15-G 1"-wd
L	400	18	G 1/4"		13.5	12	27	32	GE-LR-18-G 1/4"-wd
L	400	18	G 3/8"	33.0	12.5	12	27	32	GE-LR-18-G 3/8"-wd
L	400	18	G 1/2"	31.0	14.5	14	27	32	GE-LR-18-G 1/2"-wd
L	315	18	G 3/4"	34.0	14.5	16	32	32	GE-LR-18-G 3/4"-wd
L	250	18	G 1"		16.5	18	41	32	GE-LR-18-G 1"-wd
L	250	22	G 3/8"	49.0	16.0	12	32	36	GE-LR-22-G 3/8"-wd
L	250	22	G 1/2"	37.0	16.5	14	32	36	GE-LR-22-G 1/2"-wd
L	250	22	G 3/4"	33.0	16.5	16	32	36	GE-LR-22-G 3/4"-wd
L	250	22	G 1"		17.5	18	41	36	GE-LR-22-G 1"-wd
L	250	22	G 1 1/4"		18.5	20	50	36	GE-LR-22-G 1 1/4"-wd
L	250	28	G 1/2"		17.5	14	41	41	GE-LR-28-G 1/2"-wd
L	250	28	G 3/4"	38.0	17.5	16	41	41	GE-LR-28-G 3/4"-wd
L	250	28	G 1"		17.5	18	41	41	GE-LR-28-G 1"-wd
L	250	28	G 1 1/4"		18.5	20	50	41	GE-LR-28-G 1 1/4"-wd
L	250	28	G 1 1/2"	43.0	20.5	22	55	41	GE-LR-28-G 1 1/2"-wd
L	250	35	G 1/2"	42.0	17.5	14	46	50	GE-LR-35-G 1/2"-wd
L	250	35	G 3/4"	42.0	18.5	16	46	50	GE-LR-35-G 3/4"-wd
L	250	35	G 1"	42.0	17.5	18	46	50	GE-LR-35-G 1"-wd
L	250	35	G 1 1/4"	39.0	17.5	20	50	50	GE-LR-35-G 1 1/4"-wd
L	250	35	G 1 1/2"	44.0	19.5	22	55	50	GE-LR-35-G 1 1/2"-wd
L	250	42	G 1"	47.0	19.0	18	55	60	GE-LR-42-G 1"-wd
L	250	42	G 1 1/4"	47.0	19.0	20	55	60	GE-LR-42-G 1 1/4"-wd
L	250	42	G 1 1/2"	47.0	19.0	22	55	60	GE-LR-42-G 1 1/2"-wd
L	250	42	G 2"		21.0	23	70	60	GE-LR-42-G 2"-wd

Male stud coupling to BSP parallel

BOOK INDEX

SECTION INDEX

to ISO 8434-1 / DIN 2353

S series

Form B sealing shoulder

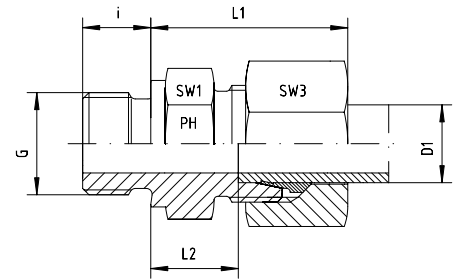
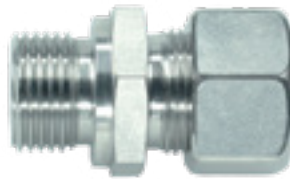

Series	Pressure PN	Tube O.D. D1	Thread G	Approx. Dimensions					Part code
				L1	L2	i	SW1	SW3	
S	630	6	G 1/8"	28.0	13.0	8	14	17	GE-SR-06-G 1/8"
S	630	6	G 1/4"	28.0	13.0	12	19	17	GE-SR-06-G 1/4"
S	630	6	G 3/8"	30.0	15.5	12	22	19	GE-SR-06-G 3/8"
S	630	6	G 1/2"	34.0	17.0	14	27	19	GE-SR-06-G 1/2"
S	630	8	G 1/8"		14.0	8	17	19	GE-SR-08-G 1/8"
S	630	8	G 1/4"	30.0	15.0	12	19	19	GE-SR-08-G 1/4"
S	630	8	G 3/8"		15.5	12	22	19	GE-SR-08-G 3/8"
S	630	8	G 1/2"		15.0	14	27	19	GE-SR-08-G 1/2"
S	630	10	G 1/8"		13.5	8	19	22	GE-SR-10-G 1/8"
S	630	10	G 1/4"		14.5	12	19	22	GE-SR-10-G 1/4"
S	630	10	G 3/8"	31.0	15.0	12	22	22	GE-SR-10-G 3/8"
S	630	10	G 1/2"		13.5	14	27	22	GE-SR-10-G 1/2"
S	630	10	G 3/4"			16	32	22	GE-SR-10-G 3/4"
S	630	12	G 1/4"		16.5	12	22	24	GE-SR-12-G 1/4"
S	630	12	G 3/8"	33.0	17.0	12	22	24	GE-SR-12-G 3/8"
S	630	12	G 1/2"	34.0	17.5	14	27	24	GE-SR-12-G 1/2"
S	630	12	G 3/4"	36.0	17.5	16	32	24	GE-SR-12-G 3/4"
S	630	14	G 1/4"	37.0	17.0	12	24	27	GE-SR-14-G 1/4"
S	630	14	G 3/8"	37.0	17.0	12	24	27	GE-SR-14-G 3/8"
S	630	14	G 1/2"	37.0	19.0	14	27	27	GE-SR-14-G 1/2"
S	400	14	G 3/4"		19.0	16	32	27	GE-SR-14-G 3/4"
S	400	16	G 1/4"	38.0	17.5	12	27	30	GE-SR-16-G 1/4"
S	400	16	G 3/8"		18.0	12	27	30	GE-SR-16-G 3/8"
S	400	16	G 1/2"	37.0	18.5	14	27	30	GE-SR-16-G 1/2"
S	400	16	G 3/4"	39.0	20.5	16	32	30	GE-SR-16-G 3/4"
S	400	16	G 1"	43.5	22.5	18	41	30	GE-SR-16-G 1"
S	400	20	G 3/8"		18.0	12	32	36	GE-SR-20-G 3/8"
S	400	20	G 1/2"		20.5	14	32	36	GE-SR-20-G 1/2"
S	400	20	G 3/4"	42.0	20.5	16	32	36	GE-SR-20-G 3/4"
S	400	20	G 1"		22.5	18	41	36	GE-SR-20-G 1"
S	400	20	G 1 1/4"		22.5	20	50	36	GE-SR-20-G 1 1/4"
S	400	25	G 1/2"		23.0	14	41	46	GE-SR-25-G 1/2"
S	400	25	G 3/4"		23.0	16	41	46	GE-SR-25-G 3/4"
S	400	25	G 1"	47.0	23.0	18	41	46	GE-SR-25-G 1"
S	250	25	G 1 1/4"		23.0	20	50	46	GE-SR-25-G 1 1/4"
S	250	30	G 3/4"		25.5	16	46	50	GE-SR-30-G 3/4"
S	250	30	G 1"	50.0	23.5	18	46	50	GE-SR-30-G 1"
S	250	30	G 1 1/4"	50.0	23.5	20	50	50	GE-SR-30-G 1 1/4"
S	250	30	G 1 1/2"	50.0	23.5	22	55	50	GE-SR-30-G 1 1/2"
S	250	38	G 1"	42.0	26.0	18	46	50	GE-SR-38-G 1"
S	250	38	G 1 1/4"		23.0	20	55	60	GE-SR-38-G 1 1/4"
S	250	38	G 1 1/2"	57.0	26.0	22	55	60	GE-SR-38-G 1 1/2"
S	250	38	G 2"				70	60	GE-SR-38-G 2"



24° compression fittings to ISO 8434-1 / DIN 2353

Male stud coupling to BSP parallel – captive seal

BOOK INDEX

SECTION INDEX

to ISO 8434-1 / DIN 2353

S series

Captive Viton elastomeric
soft seal

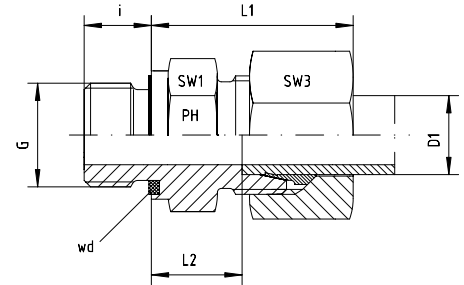
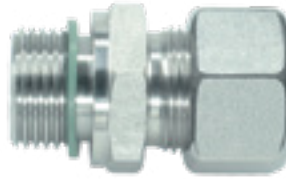

Series	Pressure PN	Tube O.D. D1	Thread G	Approx. Dimensions					Part code
				L1	L2	i	SW1	SW3	
S	800	6	G 1/8"	28.0	13.0	8		17	GE-SR-06-G 1/8"-wd
S	800	6	G 1/4"	28.0	13.0	12	19	17	GE-SR-06-G 1/4"-wd
S	800	6	G 3/8"	30.0	15.5	12	22	19	GE-SR-06-G 3/8"-wd
S	630	6	G 1/2"	34.0	17.0	14	27	19	GE-SR-06-G 1/2"-wd
S	800	8	G 1/8"		14.0	8	17	19	GE-SR-08-G 1/8"-wd
S	800	8	G 1/4"	30.0	15.0	12	19	19	GE-SR-08-G 1/4"-wd
S	800	8	G 3/8"		15.5	12	22	19	GE-SR-08-G 3/8"-wd
S	630	8	G 1/2"		15.0	14	27	19	GE-SR-08-G 1/2"-wd
S	800	10	G 1/8"		13.5	8	19	22	GE-SR-10-G 1/8"-wd
S	800	10	G 1/4"		14.5	12	19	22	GE-SR-10-G 1/4"-wd
S	800	10	G 3/8"	31.0	15.0	12	22	22	GE-SR-10-G 3/8"-wd
S	630	10	G 1/2"		13.5	14	27	22	GE-SR-10-G 1/2"-wd
S	420	10	G 3/4"	36.0	17.5	16	32	22	GE-SR-10-G 3/4"-wd
S	630	12	G 1/4"		16.5	12	22	24	GE-SR-12-G 1/4"-wd
S	630	12	G 3/8"	33.0	17.0	12	22	24	GE-SR-12-G 3/8"-wd
S	630	12	G 1/2"	34.0	17.5	14	27	24	GE-SR-12-G 1/2"-wd
S	420	12	G 3/4"	36.0	17.5	16	32	24	GE-SR-12-G 3/4"-wd
S	630	14	G 1/4"	37.0	17.0	12	24	27	GE-SR-14-G 1/4"-wd
S	630	14	G 3/8"	37.0	17.0	12	24	27	GE-SR-14-G 3/8"-wd
S	630	14	G 1/2"	37.0	19.0	14	27	27	GE-SR-14-G 1/2"-wd
S	420	14	G 3/4"		19.0	16	32	27	GE-SR-14-G 3/4"-wd
S	630	16	G 1/4"	38.0	17.5	12	27	30	GE-SR-16-G 1/4"-wd
S	630	16	G 3/8"		18.0	12	27	30	GE-SR-16-G 3/8"-wd
S	630	16	G 1/2"	37.0	18.5	14	27	30	GE-SR-16-G 1/2"-wd
S	420	16	G 3/4"	39.0	20.5	16	32	30	GE-SR-16-G 3/4"-wd
S	420	16	G 1"	43.5	22.5	18	41	30	GE-SR-16-G 1"-wd
S	420	20	G 3/8"		18.0	12	32	36	GE-SR-20-G 3/8"-wd
S	420	20	G 1/2"		20.5	14	32	36	GE-SR-20-G 1/2"-wd
S	420	20	G 3/4"	42.0	20.5	16	32	36	GE-SR-20-G 3/4"-wd
S	420	20	G 1"		22.5	18	41	36	GE-SR-20-G 1"-wd
S	420	20	G 1 1/4"		22.5	20	50	36	GE-SR-20-G 1 1/4"-wd
S	420	25	G 1/2"		23.0	14	41	46	GE-SR-25-G 1/2"-wd
S	420	25	G 3/4"		23.0	16	41	46	GE-SR-25-G 3/4"-wd
S	420	25	G 1"	47.0	23.0	18	41	46	GE-SR-25-G 1"-wd
S	420	25	G 1 1/4"		23.0	20	50	46	GE-SR-25-G 1 1/4"-wd
S	420	30	G 3/4"		25.5	16	46	50	GE-SR-30-G 3/4"-wd
S	420	30	G 1"	50.0	23.5	18	46	50	GE-SR-30-G 1"-wd
S	420	30	G 1 1/4"	50.0	23.5	20	50	50	GE-SR-30-G 1 1/4"-wd
S	420	30	G 1 1/2"	50.0	23.5	22	55	50	GE-SR-30-G 1 1/2"-wd
S	420	38	G 1"	42.0	26.0	18	46	50	GE-SR-38-G 1"-wd
S	420	38	G 1 1/4"		23.0	20	55	60	GE-SR-38-G 1 1/4"-wd
S	420	38	G 1 1/2"	57.0	26.0	22	55	60	GE-SR-38-G 1 1/2"-wd
S	250	38	G 2"				70	60	GE-SR-38-G 2"-wd

Male stud coupling to metric parallel

BOOK INDEX

SECTION INDEX

to ISO 8434-1 / DIN 2353

L series

Form B sealing shoulder

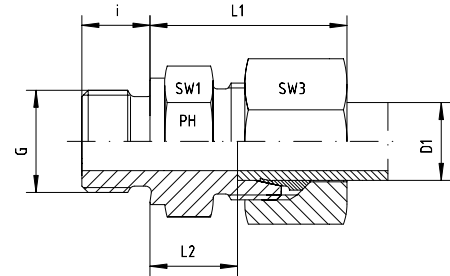
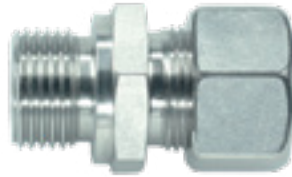

Series	Pressure PN	Tube O.D. D1	Thread G	Approx. Dimensions					Part code
				L1	L2	i	SW1	SW3	
L	315	6	M 10 x 1	23.0	8.5	8	14	14	GE-L-06-M 10x1
L	315	6	M 12 x 1.5		10.0	12	17	14	GE-L-06-M 12x1.5
L	315	6	M 14 x 1.5	27.0	10.0	12	19	14	GE-L-06-M 14x1.5
L	315	8	M 10 x 1	26.0	9.5	8	17	17	GE-L-08-M 10x1
L	315	8	M 12 x 1.5	25.0	10.0	12	17	17	GE-L-08-M 12x1.5
L	315	8	M 14 x 1.5	27.0	10.0	12	19	17	GE-L-08-M 14x1.5
L	315	8	M 16 x 1.5	27.5	11.5	12	22	17	GE-L-08-M 16x1.5
L	315	8	M 18 x 1.5	27.5	11.5	12	24	17	GE-L-08-M 18x1.5
L	315	10	M 10 x 1		11.0	8	17	19	GE-L-10-M 10x1
L	315	10	M 12 x 1.5	28.5	11.5	12	17	19	GE-L-10-M 12x1.5
L	315	10	M 14 x 1.5	26.0	11.0	12	19	19	GE-L-10-M 14x1.5
L	315	10	M 16 x 1.5	30.0	12.5	12	22	19	GE-L-10-M 16x1.5
L	315	10	M 18 x 1.5	30.0	12.5	12	24	19	GE-L-10-M 18x1.5
L	315	10	M 22 x 1.5		14.0	14	27	19	GE-L-10-M 22x1.5
L	315	12	M 12 x 1.5	28.0	13.0	12	19	22	GE-L-12-M 12x1.5
L	315	12	M 14 x 1.5	28.0	12.5	12	19	22	GE-L-12-M 14x1.5
L	315	12	M 16 x 1.5	27.0	12.5	12	22	22	GE-L-12-M 16x1.5
L	315	12	M 18 x 1.5	30.0	12.5	12	24	22	GE-L-12-M 18x1.5
L	315	12	M 22 x 1.5		14.0	14	27	22	GE-L-12-M 22x1.5
L	315	15	M 16 x 1.5	32.0	13.5	12	24	27	GE-L-15-M 16x1.5
L	315	15	M 18 x 1.5	29.0	13.5	12	24	27	GE-L-15-M 18x1.5
L	315	15	M 22 x 1.5	33.0	15.0	14	27	27	GE-L-15-M 22x1.5
L	315	18	M 18 x 1.5	33.0	14.0	12	27	32	GE-L-18-M 18x1.5
L	315	18	M 22 x 1.5	31.0	14.5	14	27	32	GE-L-18-M 22x1.5
L	160	18	M 26 x 1.5		14.5	16	32	32	GE-L-18-M 26x1.5
L	160	22	M 22 x 1.5	38.0	17.5	14	32	36	GE-L-22-M 22x1.5
L	160	22	M 26 x 1.5	33.0	16.5	16	32	36	GE-L-22-M 26x1.5
L	160	28	M 33 x 2	34.0	17.5	18	41	41	GE-L-28-M 33x2
L	160	35	M 42 x 2	39.0	17.5	20	50	50	GE-L-35-M 42x2
L	160	42	M 48 x 2	42.0	19.0	22	55	60	GE-L-42-M 48x2

Fittings can be supplied with nuts with silver-plated threads to help to prevent galling, or can be supplied body only - no nut or cutting ring.

If you require silver-plated nuts, use suffix -SC. If you require body only, use suffix -OMD.

Eg. GE-L-12-M 14x1.5-SC, or GE-L-12-M 14x1.5-OMD.

Male stud coupling to metric parallel

BOOK INDEX

SECTION INDEX

to ISO 8434-1 / DIN 2353

S series

Form B sealing shoulder

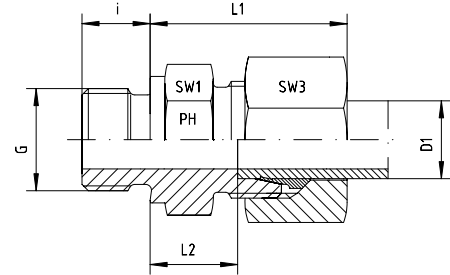
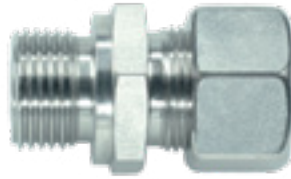

Series	Pressure PN	Tube O.D. D1	Thread G	Approx. Dimensions					Part code
				L1	L2	i	SW1	SW3	
S	630	6	M 12 x 1.5	28.0	13.0	12	17	17	GE-S-06-M 12x1.5
S	630	6	M 14 x 1.5			12	19	17	GE-S-06-M 14x1.5
S	630	8	M 12 x 1.5	32.0	15.0	12	17	19	GE-S-08-M 12x1.5
S	630	8	M 14 x 1.5	30.0	15.0	12	19	19	GE-S-08-M 14x1.5
S	630	8	M 16 x 1.5			12	22	19	GE-S-08-M 16x1.5
S	630	10	M 14 x 1.5			12	19	22	GE-S-10-M 14x1.5
S	630	10	M 16 x 1.5	31.0	15.0	12	22	22	GE-S-10-M 16x1.5
S	630	10	M 18 x 1.5	31.0	15.0	12	24	22	GE-S-10-M 18x1.5
S	630	12	M 12 x 1.5	33.5	16.5	12	22	24	GE-S-12-M 12x1.5
S	630	12	M 14 x 1.5	33.0	16.0	12	22	24	GE-S-12-M 14x1.5
S	630	12	M 16 x 1.5	35.5	17.0	12	22	24	GE-S-12-M 16x1.5
S	630	12	M 18 x 1.5	33.0	17.0	12	24	24	GE-S-12-M 18x1.5
S	630	12	M 20 x 1.5			14	27	24	GE-S-12-M 20x1.5
S	400	12	M 22 x 1.5	36.5	17.5	14	27	24	GE-S-12-M 22x1.5
S	630	14	M 20 x 1.5	37.0	19.0	14	27	27	GE-S-14-M 20x1.5
S	400	14	M 22 x 1.5			14	27	27	GE-S-14-M 22x1.5
S	400	16	M 18 x 1.5		18.0	12	27	30	GE-S-16-M 18x1.5
S	400	16	M 22 x 1.5	37.0	18.5	14	27	30	GE-S-16-M 22x1.5
S	400	20	M 27 x 2	42.5	20.5	16	32	36	GE-S-20-M 27x2
S	400	25	M 33 x 2	47.0	23.0	18	41	46	GE-S-25-M 33x2
S	250	30	M 42 x 2	50.0	23.5	20	50	50	GE-S-30-M 42x2
S	250	38	M 48 x 2	57.0	26.0	22	55	60	GE-S-38-M 48x2

Fittings can be supplied with nuts with silver-plated threads to help to prevent galling, or can be supplied body only - no nut or cutting ring.

If you require silver-plated nuts, use suffix -SC. If you require body only, use suffix -OMD.

Eg. GE-S-12-M 14x1.5-SC, or GE-S-12-M 14x1.5-OMD.

Male stud coupling to metric parallel – captive seal

BOOK INDEX

SECTION INDEX

to ISO 8434-1 / DIN 2353

LL and L series

Captive Viton elastomeric
soft seal

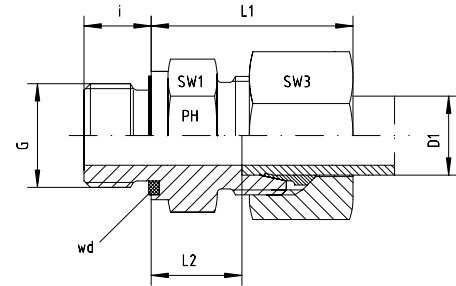
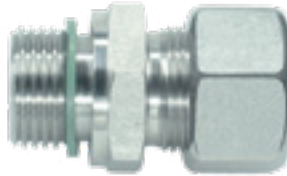

Series	Pressure PN	Tube O.D. D1	Thread G	Approx. Dimensions					Part code
				L1	L2	i	SW1	SW3	
LL	100	8	M 10 x 1		9.0	8	14	14	GE-LL-08-M 10x1-wd

Series	Pressure PN	Tube O.D. D1	Thread G	Approx. Dimensions					Part number Standard
				L1	L2	i	SW1	SW3	
L	500	6	M 10 x 1	23.0	8.5	8	14	14	GE-L-06-M 10x1-wd
L	500	6	M 12 x 1.5		10.0	12	17	14	GE-L-06-M 12x1.5-wd
L	500	6	M 14 x 1.5	27.0	10.0	12	19	14	GE-L-06-M 14x1.5-wd
L	500	8	M 10 x 1	26.0	9.5	8	17	17	GE-L-08-M 10x1-wd
L	500	8	M 12 x 1.5	25.0	10.0	12	17	17	GE-L-08-M 12x1.5-wd
L	500	8	M 14 x 1.5	27.0	10.0	12	19	17	GE-L-08-M 14x1.5-wd
L	400	8	M 16 x 1.5	27.5	11.5	12	22	17	GE-L-08-M 16x1.5-wd
L	400	8	M 18 x 1.5	27.5	11.5	12	24	17	GE-L-08-M 18x1.5-wd
L	500	10	M 10 x 1		11.0	8	17	19	GE-L-10-M 10x1-wd
L	500	10	M 12 x 1.5	28.5	11.5	12	17	19	GE-L-10-M 12x1.5-wd
L	500	10	M 14 x 1.5	26.0	11.0	12	19	19	GE-L-10-M 14x1.5-wd
L	400	10	M 16 x 1.5	30.0	12.5	12	22	19	GE-L-10-M 16x1.5-wd
L	400	10	M 18 x 1.5	30.0	12.5	12	24	19	GE-L-10-M 18x1.5-wd
L	400	10	M 22 x 1.5		14.0	14	27	19	GE-L-10-M 22x1.5-wd
L	400	12	M 12 x 1.5	28.0	13.0	12	19	22	GE-L-12-M 12x1.5-wd
L	400	12	M 14 x 1.5	28.0	12.5	12	19	22	GE-L-12-M 14x1.5-wd
L	400	12	M 16 x 1.5	27.0	12.5	12	22	22	GE-L-12-M 16x1.5-wd
L	400	12	M 18 x 1.5	30.0	12.5	12	24	22	GE-L-12-M 18x1.5-wd
L	400	12	M 22 x 1.5		14.0	14	27	22	GE-L-12-M 22x1.5-wd
L	400	15	M 16 x 1.5	32.0	13.5	12	24	27	GE-L-15-M 16x1.5-wd
L	400	15	M 18 x 1.5	29.0	13.5	12	24	27	GE-L-15-M 18x1.5-wd
L	400	15	M 22 x 1.5	33.0	15.0	14	27	27	GE-L-15-M 22x1.5-wd
L	400	18	M 18 x 1.5	33.0	14.0	12	27	32	GE-L-18-M 18x1.5-wd
L	400	18	M 22 x 1.5	31.0	14.5	14	27	32	GE-L-18-M 22x1.5-wd
L	250	18	M 26 x 1.5		14.5	16	32	32	GE-L-18-M 26x1.5-wd
L	250	22	M 22 x 1.5	38.0	17.5	14	32	36	GE-L-22-M 22x1.5-wd
L	250	22	M 26 x 1.5	33.0	16.5	16	32	36	GE-L-22-M 26x1.5-wd
L	250	28	M 33 x 2	34.0	17.5	18	41	41	GE-L-28-M 33x2-wd
L	250	35	M 42 x 2	39.0	17.5	20	50	50	GE-L-35-M 42x2-wd
L	250	42	M 48 x 2	42.0	19.0	22	55	60	GE-L-42-M 48x2-wd

Fittings can be supplied with nuts with silver-plated threads to help to prevent galling, or can be supplied body only - no nut or cutting ring.

If you require silver-plated nuts, use suffix -SC. If you require body only, use suffix -OMD.

Eg. GE-L-12-M 14x1.5-wd-SC, or GE-L-12-M 14x1.5-wd-OMD.

to ISO 8434-1 / DIN 2353

S series

Captive Viton elastomeric
soft seal

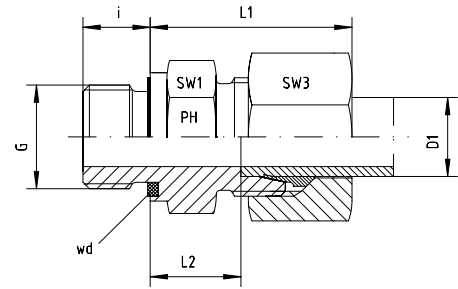
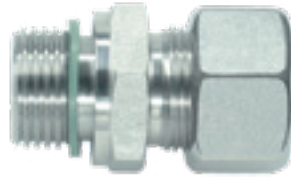

Series	Pressure PN	Tube O.D. D1	Thread G	Approx. Dimensions					Part code
				L1	L2	i	SW1	SW3	
S	800	6	M 12 x 1.5	28.0	13.0	12	17	17	GE-S-06-M 12x1.5-wd
S	800	6	M 14 x 1.5	30.0	13.0	12	19	17	GE-S-06-M 14x1.5-wd
S	800	8	M 12 x 1.5	32.0	15.0	12	17	19	GE-S-08-M 12x1.5-wd
S	800	8	M 14 x 1.5	30.0	15.0	12	19	19	GE-S-08-M 14x1.5-wd
S	800	8	M 16 x 1.5	33.0	15.5	12	22	19	GE-S-08-M 16x1.5-wd
S	800	10	M 14 x 1.5	32.0	14.5	12	19	22	GE-S-10-M 14x1.5-wd
S	800	10	M 16 x 1.5	31.0	15.0	12	22	22	GE-S-10-M 16x1.5-wd
S	630	10	M 18 x 1.5	31.0	15.0	12	24	22	GE-S-10-M 18x1.5-wd
S	630	12	M 14 x 1.5	33.0	16.0	12	22	24	GE-S-12-M 14x1.5-wd
S	630	12	M 16 x 1.5	35.5	17.0	12	22	24	GE-S-12-M 16x1.5-wd
S	630	12	M 18 x 1.5	33.0	17.0	12	24	24	GE-S-12-M 18x1.5-wd
S	630	12	M 20 x 1.5	36.0	17.5	14	27	24	GE-S-12-M 20x1.5-wd
S	630	12	M 22 x 1.5	36.5	17.5	14	27	24	GE-S-12-M 22x1.5-wd
S	630	14	M 20 x 1.5	39.0	19.0	14	27	27	GE-S-14-M 20x1.5-wd
S	630	14	M 22 x 1.5	39.0	18.5	14	27	27	GE-S-14-M 22x1.5-wd
S	630	16	M 18 x 1.5		18.0	12	27	30	GE-S-16-M 18x1.5-wd
S	630	16	M 22 x 1.5	37.0	18.5	14	27	30	GE-S-16-M 22x1.5-wd
S	420	20	M 27 x 2	42.5	20.5	16	32	36	GE-S-20-M 27x2-wd
S	420	25	M 33 x 2	47.0	23.0	18	41	46	GE-S-25-M 33x2-wd
S	420	30	M 42 x 2	50.0	23.5	20	50	50	GE-S-30-M 42x2-wd
S	420	38	M 48 x 2	57.0	26.0	22	55	60	GE-S-38-M 48x2-wd

Fittings can be supplied with nuts with silver-plated threads to help to prevent galling, or can be supplied body only - no nut or cutting ring.

If you require silver-plated nuts, use suffix -SC. If you require body only, use suffix -OMD.

Eg. GE-S-12-M 14x1.5-wd-SC, or GE-S-12-M 14x1.5-wd-OMD.

Male stud coupling to NPT

BOOK INDEX

SECTION INDEX

to ISO 8434-1 / DIN 2353

LL and L series

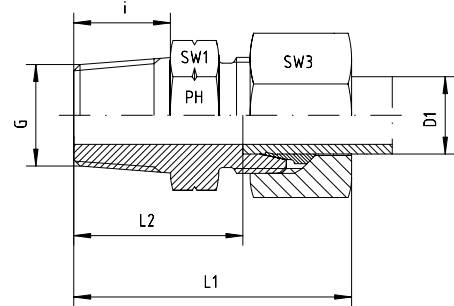
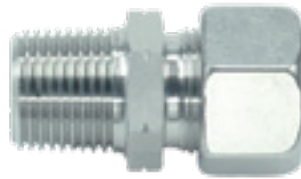

Series	Pressure PN	Tube O.D. D1	Thread G	Approx. Dimensions					Part code
				L1	L2	i	SW1	SW3	
LL	100	4	1/8" NPT	28	18.5	10.0	11	10	GE-LL-04-1/8"-NPT
LL	100	6	1/8" NPT	28	16.5	10.0	11	12	GE-LL-06-1/8"-NPT
LL	100	8	1/8" NPT	30	18.5	10.0	12	14	GE-LL-08-1/8"-NPT

Series	Pressure PN	Tube O.D. D1	Thread G	Approx. Dimensions					Part code
				L1	L2	i	SW1	SW3	
L	315	6	1/8" NPT	32	17.0	10.0	12	14	GE-L-06-1/8"-NPT
L	315	6	1/4" NPT	38	23.0	15.0	17	14	GE-L-06-1/4"-NPT
L	315	6	3/8" NPT	38	23.0	15.3	19	14	GE-L-06-3/8"-NPT
L	315	6	1/2" NPT	44	29.0	20.0	22	14	GE-L-06-1/2"-NPT
L	315	8	1/8" NPT	33	18.0	10.0	14	17	GE-L-08-1/8"-NPT
L	315	8	1/4" NPT	38	23.0	15.0	17	17	GE-L-08-1/4"-NPT
L	315	8	3/8" NPT	38	23.0	15.3	19	17	GE-L-08-3/8"-NPT
L	315	8	1/2" NPT	44	29.0	20.0	24	17	GE-L-08-1/2"-NPT
L	315	10	1/8" NPT	33	18.0	10.0	17	19	GE-L-10-1/8"-NPT
L	315	10	1/4" NPT	39	24.0	15.0	17	19	GE-L-10-1/4"-NPT
L	315	10	3/8" NPT	40	25.0	15.3	19	19	GE-L-10-3/8"-NPT
L	315	10	1/2" NPT	45	30.0	20.0	24	19	GE-L-10-1/2"-NPT
L	160	10	3/4" NPT	46	31.0	20.0	27	19	GE-L-10-3/4"-NPT
L	315	12	1/8" NPT	34	19.0	10.0	19	22	GE-L-12-1/8"-NPT
L	315	12	1/4" NPT	40	25.0	15.0	19	22	GE-L-12-1/4"-NPT
L	315	12	3/8" NPT	40	25.0	15.3	19	22	GE-L-12-3/8"-NPT
L	315	12	1/2" NPT	45	30.0	20.0	22	22	GE-L-12-1/2"-NPT
L	160	12	3/4" NPT	48	31.0	20.0	27	22	GE-L-12-3/4"-NPT
L	315	15	1/4" NPT	45	26.0	15.0	24	27	GE-L-15-1/4"-NPT
L	315	15	3/8" NPT	41	26.0	15.3	24	27	GE-L-15-3/8"-NPT
L	315	15	1/2" NPT	46	31.0	20.0	24	27	GE-L-15-1/2"-NPT
L	160	15	3/4" NPT	47	32.0	20.0	27	27	GE-L-15-3/4"-NPT
L	315	18	3/8" NPT	43	26.5	15.3	27	32	GE-L-18-3/8"-NPT
L	315	18	1/2" NPT	48	31.5	20.0	27	32	GE-L-18-1/2"-NPT
L	160	18	3/4" NPT	48	31.5	20.0	27	32	GE-L-18-3/4"-NPT
L	160	18	1" NPT	54	37.5	25.0	36	32	GE-L-18-1"-NPT
L	160	22	3/8" NPT	45	28.5	15.3	32	36	GE-L-22-3/8"-NPT
L	160	22	1/2" NPT	50	33.5	20.0	32	36	GE-L-22-1/2"-NPT
L	160	22	3/4" NPT	50	33.5	20.0	32	36	GE-L-22-3/4"-NPT
L	160	22	1" NPT	56	39.5	25.0	36	36	GE-L-22-1"-NPT
L	160	22	1 1/4" NPT	68	46.5	25.5	46	36	GE-L-22-1 1/4"-NPT
L	160	28	1/2" NPT	56	35.0	20.0	41	41	GE-L-28-1/2"-NPT
L	160	28	3/4" NPT	51	34.5	20.0	41	41	GE-L-28-3/4"-NPT
L	160	28	1" NPT	56	39.5	25.0	41	41	GE-L-28-1"-NPT
L	160	28	1 1/4" NPT	48	41.5	25.5	46	41	GE-L-28-1 1/4"-NPT
L	160	35	3/4" NPT			20.0	46	50	GE-L-35-3/4"-NPT
L	160	35	1" NPT	61	39.5	25.0	46	50	GE-L-35-1"-NPT
L	160	35	1 1/4" NPT	62	40.5	25.5	46	50	GE-L-35-1 1/4"-NPT
L	160	35	1 1/2" NPT	69	42.5	26.0	55	50	GE-L-35-1 1/2"-NPT
L	160	42	1" NPT	67	40.5	25.0	55	60	GE-L-42-1"-NPT
L	160	42	1 1/4" NPT	65	42.0	25.5	55	60	GE-L-42-1 1/4"-NPT
L	160	42	1 1/2" NPT	65	42.0	26.0	55	60	GE-L-42-1 1/2"-NPT



24° compression fittings to ISO 8434-1 / DIN 2353

Male stud coupling to NPT

BOOK INDEX

SECTION INDEX

to ISO 8434-1 / DIN 2353

S series

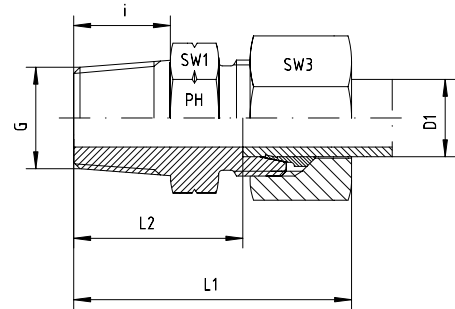
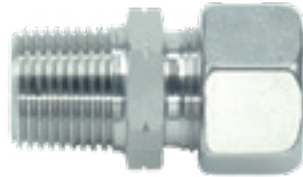

Series	Pressure PN	Tube O.D. D1	Thread G	Approx. Dimensions					Part code
				L1	L2	i	SW1	SW3	
S	630	6	1/8" NPT	36.0	21.0	10.0	14	17	GE-S-06-1/8"-NPT
S	630	6	1/4" NPT	43.0	28.0	15.0	17	17	GE-S-06-1/4"-NPT
S	630	6	3/8" NPT	41.0	26.0	15.3	19	17	GE-S-06-3/8"-NPT
S	630	6	1/2" NPT	50.0	35.0	20.0	22	17	GE-S-06-1/2"-NPT
S	630	8	1/8" NPT		23.0	10.0	17	19	GE-S-08-1/8"-NPT
S	630	8	1/4" NPT	43.0	28.0	15.0	17	19	GE-S-08-1/4"-NPT
S	630	8	3/8" NPT	43.0	28.0	15.3	19	19	GE-S-08-3/8"-NPT
S	630	8	1/2" NPT	50.0	35.0	20.0	22	19	GE-S-08-1/2"-NPT
S	630	10	1/8" NPT	40.0	22.5	10.0	19	22	GE-S-10-1/8"-NPT
S	630	10	1/4" NPT	44.0	27.5	15.0	19	22	GE-S-10-1/4"-NPT
S	630	10	3/8" NPT	44.0	27.5	15.3	19	22	GE-S-10-3/8"-NPT
S	630	10	1/2" NPT	51.0	34.5	20.0	22	22	GE-S-10-1/2"-NPT
S	400	10	3/4" NPT	50.5	31.5	20.0	27	22	GE-S-10-3/4"-NPT
S	630	12	1/4" NPT	46.0	29.5	15.0	22	24	GE-S-12-1/4"-NPT
S	630	12	3/8" NPT	46.0	29.5	15.3	22	24	GE-S-12-3/8"-NPT
S	630	12	1/2" NPT	51.0	34.5	20.0	22	24	GE-S-12-1/2"-NPT
S	400	12	3/4" NPT	53.0	36.5	20.0	27	24	GE-S-12-3/4"-NPT
S	630	14	3/8" NPT	49.0	23.0	15.3	24	27	GE-S-14-3/8"-NPT
S	630	14	1/2" NPT	54.0	36.0	20.0	24	27	GE-S-14-1/2"-NPT
S	400	14	3/4" NPT	56.0	38.0	20.0	27	27	GE-S-14-3/4"-NPT
S	400	16	3/8" NPT	49.0	30.5	15.3	27	30	GE-S-16-3/8"-NPT
S	400	16	1/2" NPT	54.0	35.5	20.0	27	30	GE-S-16-1/2"-NPT
S	400	16	3/4" NPT	56.0	37.5	20.0	30	30	GE-S-16-3/4"-NPT
S	400	16	1" NPT	63.0	44.5	25.0	36	30	GE-S-16-1"-NPT
S	400	20	3/8" NPT		32.5	15.3	32	36	GE-S-20-3/8"-NPT
S	400	20	1/2" NPT	59.0	37.5	20.0	32	36	GE-S-20-1/2"-NPT
S	400	20	3/4" NPT	59.0	37.5	20.0	32	36	GE-S-20-3/4"-NPT
S	400	20	1" NPT	66.0	44.5	25.0	36	36	GE-S-20-1"-NPT
S	400	20	1 1/4" NPT	67.5	44.5	25.5	46	36	GE-S-20-1 1/4"-NPT
S	400	25	1/2" NPT	67.5	40.0	20.0	41	46	GE-S-25-1/2"-NPT
S	400	25	3/4" NPT	64.0	40.0	20.0	41	46	GE-S-25-3/4"-NPT
S	400	25	1" NPT	69.0	45.0	25.0	41	46	GE-S-25-1"-NPT
S	400	25	1 1/4" NPT	70.0	46.0	25.5	46	46	GE-S-25-1 1/4"-NPT
S	400	30	3/4" NPT	67.0	40.5	20.0	46	50	GE-S-30-3/4"-NPT
S	400	30	1" NPT	72.0	45.5	25.0	46	50	GE-S-30-1"-NPT
S	400	30	1 1/4" NPT	73.0	46.5	25.5	46	50	GE-S-30-1 1/4"-NPT
S	315	30	1 1/2" NPT	73.0	46.5	26.0	55	50	GE-S-30-1 1/2"-NPT
S	315	38	1" NPT	79.0	48.0	25.0	55	60	GE-S-38-1"-NPT
S	315	38	1 1/4" NPT	80.0	49.0	25.5	55	60	GE-S-38-1 1/4"-NPT
S	315	38	1 1/2" NPT	80.0	49.0	26.0	55	60	GE-S-38-1 1/2"-NPT

Male stud coupling to BSP taper

BOOK INDEX

SECTION INDEX

to ISO 8434-1 / DIN 2353

LL and L series

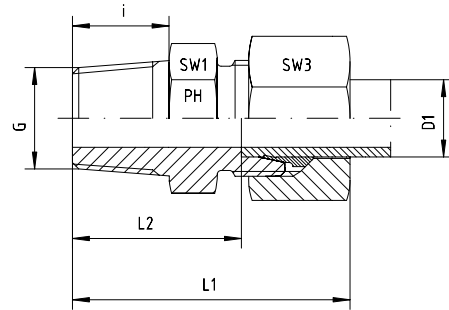
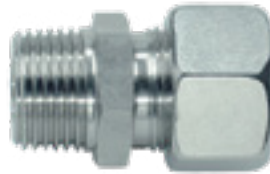

Series	Pressure PN	Tube O.D. D1	Thread G	Approx. Dimensions					Part code
				L1	L2	i	SW1	SW3	
LL	100	4	R 1/8" keg	26	16.0	8	11	10	GE-LL-04-R 1/8"-k
LL	100	6	R 1/8" keg	26	14.5	8	11	12	GE-LL-06-R 1/8"-k
LL	100	6	R 1/4" keg	31	18.5	12	14	12	GE-LL-06-R 1/4"-k
LL	100	8	R 1/8" keg	28	16.5	8	12	14	GE-LL-08-R 1/8"-k
LL	100	8	R 1/4" keg	32	20.5	12	14	12	GE-LL-08-R 1/4"-k

Series	Pressure PN	Tube O.D. D1	Thread G	Approx. Dimensions					Part code
				L1	L2	i	SW1	SW3	
L	315	6	R 1/8" keg	30	15.0	8	14	14	GE-L-06-R 1/8"-k
L	315	6	R 1/4" keg	35	20.0	12	17	14	GE-L-06-R 1/4"-k
L	315	6	R 3/8" keg	36	21.0	12	17	14	GE-L-06-R 3/8"-k
L	315	6	R 1/2" keg	40	23.0	14	22	14	GE-L-06-R 1/2"-k
L	315	8	R 1/8" keg	31	16.0	8	14	17	GE-L-08-R 1/8"-k
L	315	8	R 1/4" keg	35	20.0	12	17	17	GE-L-08-R 1/4"-k
L	315	8	R 3/8" keg	35	20.0	12	17	17	GE-L-08-R 3/8"-k
L	315	8	R 1/2" keg	38	22.0	14	22	17	GE-L-08-R 1/2"-k
L	315	10	R 1/8" keg	32	17.0	8	17	19	GE-L-10-R 1/8"-k
L	315	10	R 1/4" keg	36	21.0	12	17	19	GE-L-10-R 1/4"-k
L	315	10	R 3/8" keg	36	21.0	12	17	19	GE-L-10-R 3/8"-k
L	315	10	R 1/2" keg	39	24.0	14	22	19	GE-L-10-R 1/2"-k
L	315	12	R 1/8" keg			8	19	22	GE-L-12-R 1/8"-k
L	315	12	R 1/4" keg	37	22.0	12	19	22	GE-L-12-R 1/4"-k
L	315	12	R 3/8" keg	37	22.0	12	19	22	GE-L-12-R 3/8"-k
L	315	12	R 1/2" keg	39	24.0	14	22	22	GE-L-12-R 1/2"-k
L	160	12	R 3/4" keg	43	27.0	16	27	22	GE-L-12-R 3/4"-k
L	315	15	R 1/4" keg			12	24	27	GE-L-15-R 1/4"-k
L	315	15	R 3/8" keg	38	23.0	12	24	27	GE-L-15-R 3/8"-k
L	315	15	R 1/2" keg	40	25.0	14	24	27	GE-L-15-R 1/2"-k
L	160	15	R 3/4" keg	45	28.0	16	27	27	GE-L-15-R 3/4"-k
L	315	18	R 3/8" keg	42	23.5	12	27	32	GE-L-18-R 3/8"-k
L	315	18	R 1/2" keg	42	25.5	14	27	32	GE-L-18-R 1/2"-k
L	160	18	R 3/4" keg	47	27.5	16	27	32	GE-L-18-R 3/4"-k
L	160	22	R 3/8" keg	46	25.5	12	32	36	GE-L-22-R 3/8"-k
L	160	22	R 1/2" keg	46	25.5	14	32	36	GE-L-22-R 1/2"-k
L	160	22	R 3/4" keg	46	29.5	16	32	36	GE-L-22-R 3/4"-k
L	160	22	R 1" keg	50	31.5	18	36	36	GE-L-22-R 1"-k
L	160	28	R 1/2" keg			14	41	41	GE-L-28-R 1/2"-k
L	160	28	R 3/4" keg	49	30.5	16	41	41	GE-L-28-R 3/4"-k
L	160	28	R 1" keg	49	32.5	18	41	41	GE-L-28-R 1"-k
L	160	28	R 1 1/4" keg	49	30.5	20	46	41	GE-L-28-R 1 1/4"-k
L	160	35	R 1" keg	51	27.5	18	46	50	GE-L-35-R 1"-k
L	160	35	R 1 1/4" keg	56	34.5	20	46	50	GE-L-35-R 1 1/4"-k
L	160	35	R 1 1/2" keg	63	37.5	22	50	50	GE-L-35-R 1 1/2"-k
L	160	42	R 1 1/4" keg	55	31.0	20	55	60	GE-L-42-R 1 1/4"-k
L	160	42	R 1 1/2" keg	61	38.0	22	55	60	GE-L-42-R 1 1/2"-k

Male stud coupling to BSP taper

BOOK INDEX

SECTION INDEX

to ISO 8434-1 / DIN 2353

S series

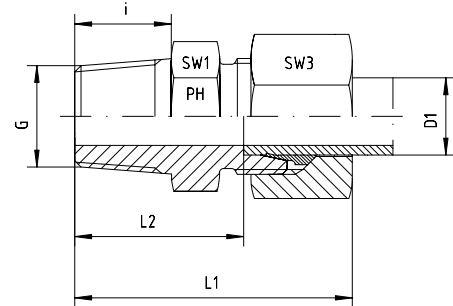
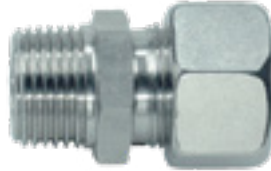

Series	Pressure PN ⁽¹⁾	Tube O.D. D1	Thread G	Approx. Dimensions					Part code
				L1	L2	i	SW1	SW3	
S	630	6	R 1/8" keg			8	17	17	GE-S-06-R 1/8"-k
S	630	6	R 1/4" keg	40.0	25.0	12	17	17	GE-S-06-R 1/4"-k
S	630	6	R 3/8" keg	40.0	25.0	12	17	17	GE-S-06-R 3/8"-k
S	630	8	R 1/8" keg	35.0	19.0	8	17	19	GE-S-08-R 1/8"-k
S	630	8	R 1/4" keg	40.0	25.0	12	17	19	GE-S-08-R 1/4"-k
S	630	8	R 3/8" keg	40.0	25.0	12	19	19	GE-S-08-R 3/8"-k
S	630	10	R 1/4" keg	41.0	25.0	12	19	22	GE-S-10-R 1/4"-k
S	630	10	R 3/8" keg	41.0	25.0	12	19	22	GE-S-10-R 3/8"-k
S	630	10	R 1/2" keg			14	22	22	GE-S-10-R 1/2"-k
S	630	12	R 1/4" keg	43.0	26.5	12	22	24	GE-S-12-R 1/4"-k
S	630	12	R 3/8" keg	42.0	25.0	12	22	24	GE-S-12-R 3/8"-k
S	630	12	R 1/2" keg	44.0	26.5	14	22	24	GE-S-12-R 1/2"-k
S	630	14	R 3/8" keg	46.0	27.0	12	24	27	GE-S-14-R 3/8"-k
S	630	14	R 1/2" keg	50.5	32.0	14	24	27	GE-S-14-R 1/2"-k
S	400	16	R 3/8" keg	48.0	28.5	12	27	30	GE-S-16-R 3/8"-k
S	400	16	R 1/2" keg	49.0	29.0	14	27	30	GE-S-16-R 1/2"-k
S	400	16	R 3/4" keg	53.0	31.5	16	27	30	GE-S-16-R 3/4"-k
S	400	20	R 1/2" keg	54.0	29.5	14	32	36	GE-S-20-R 1/2"-k
S	400	20	R 3/4" keg	55.0	33.5	16	32	36	GE-S-20-R 3/4"-k
S	160	20	R 1" keg	58.0	35.5	18	36	36	GE-S-20-R 1"-k
S	160	25	R 3/4" keg			16	41	46	GE-S-25-R 3/4"-k
S	160	25	R 1" keg	59.0	33.0	18	41	46	GE-S-25-R 1"-k
S	160	30	R 1 1/4" keg	63.0	35.5	20	46	50	GE-S-30-R 1 1/4"-k
S	160	38	R 1 1/2" keg	81.0	49.0	22	55	60	GE-S-38-R 1 1/2"-k

⁽¹⁾ These pressure ratings are only valid when screwed into a taper female thread.

Fittings can be supplied with nuts with silver-plated threads to help to prevent galling, or can be supplied body only - no nut or cutting ring.

If you require silver-plated nuts, use suffix -SC. If you require body only, use suffix -OMD.

Eg. GE-S-12-R 3/8"-k-SC, or GE-S-12-R 3/8"-k-OMD

Male stud coupling to metric taper

BOOK INDEX

SECTION INDEX

to ISO 8434-1 / DIN 2353

LL and L series

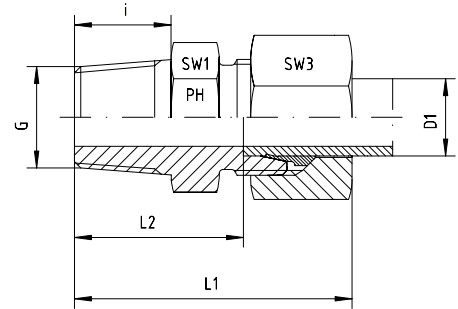
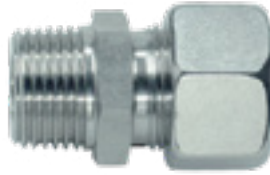

Series	Pressure PN	Tube O.D. D1	Thread G	Approx. Dimensions					Part code
				L1	L2	i	SW1	SW3	
LL	100	4	M 6 x 1 keg	26.0	16.0	8	10	10	GE-LL-04-M 6x1-k
LL	100	4	M 8 x 1 keg	26.0	16.0	8	10	10	GE-LL-04-M 8x1-k
LL	100	4	M 10 x 1 keg	26.0	16.0	8	11	10	GE-LL-04-M 10x1-k
LL	100	6	M 6 x 1 keg	26.0	14.5	8	11	12	GE-LL-06-M 6x1-k
LL	100	6	M 8 x 1 keg	26.0	14.5	8	11	12	GE-LL-06-M 8x1-k
LL	100	6	M 10 x 1 keg	26.0	14.5	8	11	12	GE-LL-06-M 10x1-k
LL	100	8	M 6 x 1 keg	28.0	16.5	8	12	14	GE-LL-08-M 6x1-k
LL	100	8	M 8 x 1 keg	28.0	16.5	8	12	14	GE-LL-08-M 8x1-k
LL	100	8	M 10 x 1 keg	28.0	16.5	8	12	14	GE-LL-08-M 10x1-k

Series	Pressure PN	Tube O.D. D1	Thread G	Approx. Dimensions					Part code
				L1	L2	i	SW1	SW3	
L	315	6	M 10 x 1 keg	30.5	16.0	8	14	14	GE-L-06-M 10x1-k
L	315	8	M 12 x 1.5 keg	35.0	20.0	12	17	17	GE-L-08-M 12x1.5-k
L	315	10	M 14 x 1.5 keg	36.0	21.0	12	17	19	GE-L-10-M 14x1.5-k
L	315	12	M 16 x 1.5 keg	37.0	22.0	12	19	22	GE-L-12-M 16x1.5-k
L	315	15	M 18 x 1.5 keg	40.0	23.0	12	24	27	GE-L-15-M 18x1.5-k
L	315	18	M 22 x 1.5 keg	42.0	25.5	14	27	32	GE-L-18-M 22x1.5-k

Fittings can be supplied with nuts with silver-plated threads to help to prevent galling, or can be supplied body only - no nut or cutting ring.

If you require silver-plated nuts, use suffix -SC. If you require body only, use suffix -OMD.

Eg. GE-L-12-M 16x1.5-k-SC, or GE-L-12-M 16x1.5-k-OMD.

Male stud coupling to UNF

BOOK INDEX

SECTION INDEX

to ISO 8434-1 / DIN 2353

L series

UNF thread to ASA B 1.1-1960 / J514

Note - correct port dimensions must be created.

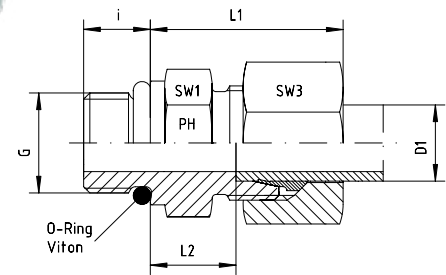

Series	Pressure PN	Tube O.D. D1	Thread G	Approx. Dimensions					O-ring	Part code
				L1	L2	i	SW1	SW3		
L	315	6	7/16"-20 UNF	23.5	9.0	9.2	17	14	8.92 x 1.83	GE-L-06-7/16"-UNF
L	315	6	1/2"-20 UNF		10.0	9.2	17	14	10.52 x 1.83	GE-L-06-1/2"-UNF
L	315	6	9/16"-18 UNF			10.0	19	14	11.90 x 1.98	GE-L-06-9/16"-UNF
L	315	8	7/16"-20 UNF	25.0	10.0	9.2	17	17	8.92 x 1.83	GE-L-08-7/16"-UNF
L	315	8	1/2"-20 UNF	25.0	10.0	9.2	17	17	10.52 x 1.83	GE-L-08-1/2"-UNF
L	315	8	9/16"-18 UNF	25.0	10.0	10.0	19	17	11.90 x 1.98	GE-L-08-9/16"-UNF
L	315	10	7/16"-20 UNF	26.0	11.0	9.2	17	19	8.92 x 1.83	GE-L-10-7/16"-UNF
L	315	10	1/2"-20 UNF	26.0	11.0	9.2	17	19	10.52 x 1.83	GE-L-10-1/2"-UNF
L	315	10	9/16"-18 UNF	26.0	11.0	10.0	19	19	11.90 x 1.98	GE-L-10-9/16"-UNF
L	315	10	3/4"-16 UNF	30.5	13.0	11.2	24	19	16.36 x 2.20	GE-L-10-3/4"-UNF
L	315	12	9/16"-18 UNF	26.0	12.5	10.0	19	22	11.90 x 1.98	GE-L-12-9/16"-UNF
L	315	12	3/4"-16 UNF	27.0	12.5	11.2	24	22	16.36 x 2.20	GE-L-12-3/4"-UNF
L	315	12	7/8"-14 UNF	27.5	13.5	12.7	27	22	19.18 x 2.46	GE-L-12-7/8"-UNF
L	315	15	9/16"-18 UNF	29.0	14.0	10.0	24	27	11.90 x 1.98	GE-L-15-9/16"-UNF
L	315	15	3/4"-16 UNF	29.0	14.0	11.2	24	27	16.36 x 2.20	GE-L-15-3/4"-UNF
L	315	15	7/8"-14 UNF	29.0	14.0	12.7	27	27	19.18 x 2.46	GE-L-15-7/8"-UNF
L	315	18	3/4"-16 UNF	31.0	14.5	11.2	27	32	16.36 x 2.20	GE-L-18-3/4"-UNF
L	315	18	7/8"-14 UNF	31.0	14.5	12.7	27	32	19.18 x 2.46	GE-L-18-7/8"-UNF
L	315	18	1 1/16"-12 UNF	31.0	14.5	15.0	32	32	23.47 x 2.95	GE-L-18-1 1/16"-UNF
L	160	22	3/4"-16 UNF	33.0	16.5	11.2	32	36	16.36 x 2.20	GE-L-22-3/4"-UNF
L	160	22	7/8"-14 UNF	33.0	16.5	12.7	32	36	19.18 x 2.46	GE-L-22-7/8"-UNF
L	160	22	1 1/16"-12 UNF	33.0	16.5	15.0	32	36	23.47 x 2.95	GE-L-22-1 1/16"-UNF
L	160	22	1 5/16"-12 UNF	33.0	16.5	15.0	41	36	29.74 x 2.95	GE-L-22-1 5/16"-UNF
L	160	28	7/8"-14 UNF	34.0	17.5	12.7	41	41	19.18 x 2.46	GE-L-28-7/8"-UNF
L	160	28	1 1/16"-12 UNF	34.0	17.5	15.0	41	41	23.47 x 2.95	GE-L-28-1 1/16"-UNF
L	160	28	1 5/16"-12 UNF	34.0	17.5	15.0	41	41	29.74 x 2.95	GE-L-28-1 5/16"-UNF
L	160	28	1 5/8"-12 UNF	34.0	17.5	15.0	50	41	37.46 x 3.00	GE-L-28-1 5/8"-UNF
L	160	35	1 1/16"-12 UNF	39.0	17.5	15.0	46	50	23.47 x 2.95	GE-L-35-1 1/16"-UNF
L	160	35	1 5/16"-12 UNF	39.0	17.5	15.0	46	50	29.74 x 2.95	GE-L-35-1 5/16"-UNF
L	160	35	1 5/8"-12 UNF	39.0	17.5	15.0	50	50	37.46 x 3.00	GE-L-35-1 5/8"-UNF
L	160	42	1 5/8"-12 UNF	42.0	19.0	15.0	55	60	37.46 x 3.00	GE-L-42-1 5/8"-UNF
L	160	42	1 7/8"-12 UNF	42.0	19.0	15.0	55	60	43.69 x 3.00	GE-L-42-1 7/8"-UNF

Fittings can be supplied with nuts with silver-plated threads to help to prevent galling, or can be supplied body only - no nut or cutting ring.

If you require silver-plated nuts, use suffix -SC. If you require body only, use suffix -OMD.

Eg. GE-L-12-3/4"-UNF-SC, or GE-L-12-3/4"-UNF-OMD.

Male stud coupling to UNF

BOOK INDEX

SECTION INDEX

to ISO 8434-1 / DIN 2353

S series

UNF thread to ASA B 1.1-1960 / J514

Note - correct port dimensions must be created.

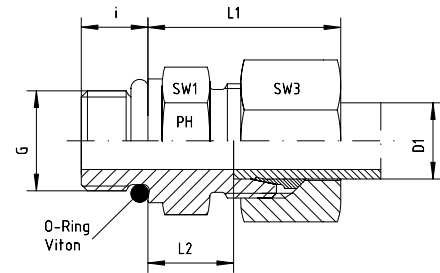

Series	Pressure PN	Tube O.D. D1	Thread G	Approx. Dimensions					O-ring	Part code
				L1	L2	i	SW1	SW3		
S	630	6	7/16"-20 UNF	28.0	13.0	9.2	17	17	8.92 x 1.83	GE-S-06-7/16"-UNF
S	630	6	9/16"-18 UNF	29.0	13.0	10.0	19	17	11.90 x 1.98	GE-S-06-9/16"-UNF
S	630	8	7/16"-20 UNF	30.0	15.0	9.2	17	19	8.92 x 1.83	GE-S-08-7/16"-UNF
S	630	8	1/2"-20 UNF	30.0	15.0	9.2	17	19	10.52 x 1.83	GE-S-08-1/2"-UNF
S	630	8	9/16"-18 UNF	30.0	13.0	10.0	19	19	11.90 x 1.98	GE-S-08-9/16"-UNF
S	630	10	9/16"-18 UNF	31.0	15.5	10.0	19	22	11.90 x 1.98	GE-S-10-9/16"-UNF
S	630	10	3/4"-16 UNF	31.0	15.0	11.2	24	22	16.36 x 2.20	GE-S-10-3/4"-UNF
S	630	12	9/16"-18 UNF		14.5	10.0	22	24	11.90 x 1.98	GE-S-12-9/16"-UNF
S	630	12	3/4"-16 UNF	33.5	17.5	11.2	24	24	16.36 x 2.20	GE-S-12-3/4"-UNF
S	630	12	7/8"-14 UNF	32.5	14.8	12.7	27	24	19.18 x 2.46	GE-S-12-7/8"-UNF
S	630	14	9/16"-18 UNF	37.0	19.0	10.0	24	27	11.90 x 1.98	GE-S-14-9/16"-UNF
S	630	14	3/4"-16 UNF	37.0	19.0	11.2	24	27	16.36 x 2.20	GE-S-14-3/4"-UNF
S	400	16	3/4"-16 UNF	37.0	18.5	11.2	27	30	16.36 x 2.20	GE-S-16-3/4"-UNF
S	400	16	7/8"-14 UNF	33.5	15.5	14.0	30	30	19.18 x 2.46	GE-S-16-7/8"-UNF
S	400	16	1 1/16"-12 UNF	37.0	18.5	15.0	32	30	23.47 x 2.95	GE-S-16-1 1/16"-UNF
S	400	20	3/4"-16 UNF	42.0	20.5	11.2	32	36	16.36 x 2.20	GE-S-20-3/4"-UNF
S	400	20	7/8"-14 UNF	42.0	20.5	12.7	32	36	19.18 x 2.46	GE-S-20-7/8"-UNF
S	400	20	1 1/16"-12 UNF	42.0	20.5	15.0	32	36	23.47 x 2.95	GE-S-20-1 1/16"-UNF
S	400	20	1 5/16"-12 UNF		22.5	15.0	41	36	29.74 x 2.95	GE-S-20-1 5/16"-UNF
S	400	25	1 1/16"-12 UNF	47.0	23.0	15.0	41	46	23.47 x 2.95	GE-S-25-1 1/16"-UNF
S	400	25	1 5/16"-12 UNF	47.0	23.0	15.0	41	46	29.74 x 2.95	GE-S-25-1 5/16"-UNF
S	400	30	1 1/16"-12 UNF	50.0	23.5	15.0	46	50	23.47 x 2.95	GE-S-30-1 1/16"-UNF
S	400	30	1 5/16"-12 UNF	50.0	23.5	15.0	46	50	29.74 x 2.95	GE-S-30-1 5/16"-UNF
S	400	30	1 5/8"-12 UNF	50.0	23.5	15.0	50	50	37.46 x 3.00	GE-S-30-1 5/8"-UNF
S	315	38	1 5/8"-12 UNF	57.0	26.0	15.0	55	60	37.46 x 3.00	GE-S-38-1 5/8"-UNF
S	315	38	1 7/8"-12 UNF	57.0	26.0	15.0	55	60	43.69 x 3.00	GE-S-38-1 7/8"-UNF

Fittings can be supplied with nuts with silver-plated threads to help to prevent galling, or can be supplied body only - no nut or cutting ring.

If you require silver-plated nuts, use suffix -SC. If you require body only, use suffix -OMD.

Eg. GE-S-12-3/4"-UNF-SC, or GE-S-12-3/4"-UNF-OMD.

Male stud elbow to BSP taper

BOOK INDEX

SECTION INDEX

to ISO 8434-1 / DIN 2353

LL and L series

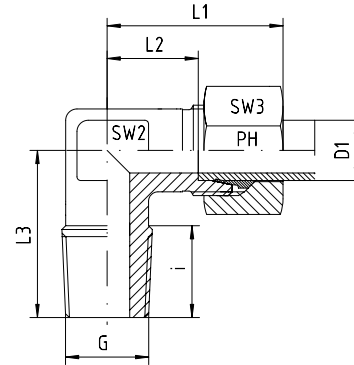

Series	Pressure PN	Tube O.D. D1	Thread G	Approx. Dimensions						Part code
				L1	L2	L3	i	SW2	SW3	
LL	100	4	R 1/8" keg	21.0	11.0	17	8	9	10	WE-LL-04-R 1/8"-k
LL	100	6	R 1/8" keg	21.0	9.5	17	8	9	12	WE-LL-06-R 1/8"-k
LL	100	8	R 1/8" keg	23.0	11.5	20	8	12	14	WE-LL-08-R 1/8"-k

Series	Pressure PN	Tube O.D. D1	Thread G	Approx. Dimensions						Part code
				L1	L2	L3	i	SW2	SW3	
L	315	6	R 1/8" keg	27.0	12.0	20	8	12	14	WE-L-06-R 1/8"-k
L	315	6	R 1/4" keg	27.0	12.0	26	12	12	14	WE-L-06-R 1/4"-k
L	315	6	R 3/8" keg	30.0	15.0	27	12	14	14	WE-L-06-R 3/8"-k
L	315	6	R 1/2" keg	30.5	15.5	30	14	17	14	WE-L-06-R 1/2"-k
L	315	8	R 1/8" keg	29.0	14.0	26	8	12	17	WE-L-08-R 1/8"-k
L	315	8	R 1/4" keg	29.0	14.0	26	12	12	17	WE-L-08-R 1/4"-k
L	315	8	R 3/8" keg	32.0	17.0	28	12	14	17	WE-L-08-R 3/8"-k
L	315	8	R 1/2" keg	34.5	19.5	30	14	17	17	WE-L-08-R 1/2"-k
L	315	10	R 1/8" keg	31.5	15.0	27	8	14	19	WE-L-10-R 1/8"-k
L	315	10	R 1/4" keg	30.0	15.0	27	12	14	19	WE-L-10-R 1/4"-k
L	315	10	R 3/8" keg	30.0	15.0	28	12	14	19	WE-L-10-R 3/8"-k
L	315	10	R 1/2" keg	37.0	21.0	33	14	17	19	WE-L-10-R 1/2"-k
L	315	12	R 1/8" keg	32.0	17.5	27	8	17	22	WE-L-12-R 1/8"-k
L	315	12	R 1/4" keg	32.0	17.5	27	12	17	22	WE-L-12-R 1/4"-k
L	315	12	R 3/8" keg	32.0	17.5	28	12	17	22	WE-L-12-R 3/8"-k
L	315	12	R 1/2" keg	32.0	17.5	34	14	17	22	WE-L-12-R 1/2"-k
L	315	15	R 1/4" keg	36.0	21.0	32	12	19	27	WE-L-15-R 1/4"-k
L	315	15	R 3/8" keg	36.0	21.0		12	19	27	WE-L-15-R 3/8"-k
L	315	15	R 1/2" keg	36.0	21.0	34	14	19	27	WE-L-15-R 1/2"-k
L	160	15	R 3/4" keg				16	24	27	WE-L-15-R 3/4"-k
L	315	18	R 3/8" keg	40.0	23.5		12	24	32	WE-L-18-R 3/8"-k
L	315	18	R 1/2" keg	40.0	23.5	36	14	24	32	WE-L-18-R 1/2"-k
L	160	18	R 3/4" keg	38.5	22.0	41	16	24	32	WE-L-18-R 3/4"-k
L	160	22	R 1/2" keg	44.0	27.5	41	14	27	36	WE-L-22-R 1/2"-k
L	160	22	R 3/4" keg	44.0	27.5	41	16	27	36	WE-L-22-R 3/4"-k
L	160	28	R 1" keg	51.5	30.5	47	20	36	41	WE-L-28-R 1"-k
L	160	35	R 1 1/4" keg	59.5	33.0	56	26	41	50	WE-L-35-R 1 1/4"-k

Fittings can be supplied with nuts with silver-plated threads to help to prevent galling, or can be supplied body only - no nut or cutting ring.

If you require silver-plated nuts, use suffix -SC. If you require body only, use suffix -OMD.

Eg. WE-L-12-R 3/8"-k-SC, or WE-L-12-R 3/8"-k-OMD.

Male stud elbow to BSP taper

BOOK INDEX

SECTION INDEX

to ISO 8434-1 / DIN 2353

S series

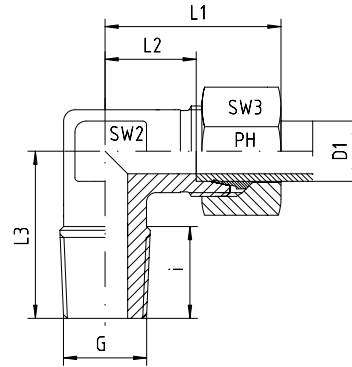

Series	Pressure PN ⁽¹⁾	Tube O.D. D1	Thread G	Approx. Dimensions						Part code
				L1	L2	L3	i	SW2	SW3	
S	630	6	R 1/8" keg	29.5	15.0	25	8	12	17	WE-S-06-R 1/8"-k
S	630	6	R 1/4" keg	31.0	16.5	26	12	12	17	WE-S-06-R 1/4"-k
S	630	6	R 3/8" keg	32.0	17.5	27	12	14	17	WE-S-06-R 3/8"-k
S	630	6	R 1/2" keg	34.0	19.0	33	14	17	17	WE-S-06-R 1/2"-k
S	630	8	R 1/8" keg				8	14	19	WE-S-08-R 1/8"-k
S	630	8	R 1/4" keg	32.0	17.0	27	12	14	19	WE-S-08-R 1/4"-k
S	630	8	R 3/8" keg	33.0	18.0	28	12	14	19	WE-S-08-R 3/8"-k
S	630	8	R 1/2" keg	38.0	23.0	33	14	17	19	WE-S-08-R 1/2"-k
S	630	10	R 1/8" keg				8	17	22	WE-S-10-R 1/8"-k
S	630	10	R 1/4" keg	34.0	17.5	28	12	17	22	WE-S-10-R 1/4"-k
S	630	10	R 3/8" keg	34.0	17.5	28	12	17	22	WE-S-10-R 3/8"-k
S	630	10	R 1/2" keg	39.0	22.5	32	14	17	22	WE-S-10-R 1/2"-k
S	630	12	R 1/4" keg	38.0	21.5	27	12	17	24	WE-S-12-R 1/4"-k
S	630	12	R 3/8" keg	38.0	21.5	28	12	17	24	WE-S-12-R 3/8"-k
S	630	12	R 1/2" keg	39.0	22.5	32	14	17	24	WE-S-12-R 1/2"-k
S	630	14	R 3/8" keg	40.0	22.0	30	12	19	27	WE-S-14-R 3/8"-k
S	630	14	R 1/2" keg	40.0	22.0	32	14	19	27	WE-S-14-R 1/2"-k
S	400	16	R 3/8" keg	43.0	24.5	32	12	24	30	WE-S-16-R 3/8"-k
S	400	16	R 1/2" keg	43.0	24.5	32	14	24	30	WE-S-16-R 1/2"-k
S	160	16	R 3/4" keg	43.0	24.5	41	16	24	30	WE-S-16-R 3/4"-k
S	400	20	R 1/2" keg	48.0	26.5	42	14	27	36	WE-S-20-R 1/2"-k
S	400	20	R 3/4" keg	48.0	26.5	42	16	27	36	WE-S-20-R 3/4"-k

⁽¹⁾ These pressure ratings are only valid when screwed into a taper female thread.

Fittings can be supplied with nuts with silver-plated threads to help to prevent galling, or can be supplied body only - no nut or cutting ring.

If you require silver-plated nuts, use suffix -SC. If you require body only, use suffix -OMD.

Eg. WE-S-12-R 3/8"-k-SC, or WE-S-12-R 3/8"-k-OMD.

to ISO 8434-1 / DIN 2353

L and S series

Form B sealing shoulder

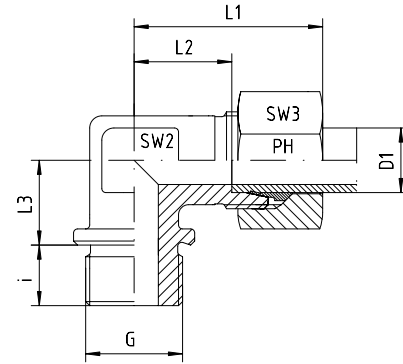

Series	Pressure PN	Tube O.D. D1	Thread G	Approx. Dimensions						Part code
				L1	L2	L3	i	SW2	SW3	
L	160	22	G 3/4" zyl	44	27.5	26	16	27	36	WE-L-22-G 3/4"-z
L	160	28	G 1" zyl	47	30.5	30	18	36	41	WE-L-28-G 1"-z
L	160	35	G 1 1/4" zyl	56	34.5	34	20	41	50	WE-L-35-G 1 1/4"-z
L	160	42	G 1 1/2" zyl	63	40.0	39	22	50	60	WE-L-42-G 1 1/2"-z

Series	Pressure PN	Tube O.D. D1	Thread G	Approx. Dimensions						Part code
				L1	L2	L3	i	SW2	SW3	
S	400	20	G 3/4" zyl	48	26.5	26	16	27	36	WE-S-20-G 3/4"-z
S	250	25	G 1" zyl	54	30.0	30	18	36	46	WE-S-25-G 1"-z
S	160	30	G 1 1/4" zyl	62	35.5	34	20	41	50	WE-S-30-G 1 1/4"-z
S	160	38	G 1 1/2" zyl	72	41.0	39	22	50	60	WE-S-38-G 1 1/2"-z

Fittings can be supplied with nuts with silver-plated threads to help to prevent galling, or can be supplied body only - no nut or cutting ring.

If you require silver-plated nuts, use suffix -SC. If you require body only, use suffix -OMD.

Eg. WE-L-22-G 3/4"-z-SC, or WE-L-22-G 3/4"-z-OMD.

Male stud elbow to metric taper

BOOK INDEX

SECTION INDEX

to ISO 8434-1 / DIN 2353

LL, L and S series

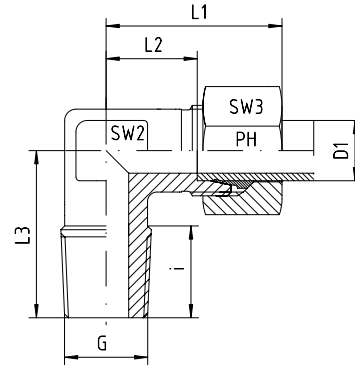

Series	Pressure PN	Tube O.D. D1	Thread G	Approx. Dimensions						Part code
				L1	L2	L3	i	SW2	SW3	
LL	100	4	M 6 x 1 keg	21	11.0	17	8	9	10	WE-LL-04-M 6x1-k
LL	100	4	M 8 x 1 keg	21	11.0	17	8	9	10	WE-LL-04-M 8x1-k
LL	100	4	M 10 x 1 keg	21	11.0	17	8	9	10	WE-LL-04-M 10x1-k
LL	100	6	M 6 x 1 keg	23	10.0	17	8	9	12	WE-LL-06-M 6x1-k
LL	100	6	M 8 x 1 keg	23	10.0	17	8	9	12	WE-LL-06-M 8x1-k
LL	100	6	M 10 x 1 keg	21	9.5	17	8	9	12	WE-LL-06-M 10x1-k
LL	100	8	M 6 x 1 keg	23	11.5	20	8	12	14	WE-LL-08-M 6x1-k
LL	100	8	M 8 x 1 keg	23	11.5	20	8	12	14	WE-LL-08-M 8x1-k
LL	100	8	M 10 x 1 keg	23	11.5	20	8	12	14	WE-LL-08-M 10x1-k

Series	Pressure PN	Tube O.D. D1	Thread G	Approx. Dimensions						Part code
				L1	L2	L3	i	SW2	SW3	
L	315	6	M 10 x 1 keg	27	12.0	20	8	12	14	WE-L-06-M 10x1-k
L	315	8	M 12 x 1.5 keg	29	14.0	26	12	12	17	WE-L-08-M 12x1.5-k
L	315	10	M 12 x 1.5 keg	30	15.0	27	12	14	19	WE-L-10-M 12x1.5-k
L	315	10	M 14 x 1.5 keg	30	15.0	27	12	14	19	WE-L-10-M 14x1.5-k
L	315	10	M 16 x 1.5 keg	30	15.0	28	12	14	19	WE-L-10-M 16x1.5-k
L	315	12	M 16 x 1.5 keg	32	17.0	28	12	17	22	WE-L-12-M 16x1.5-k
L	315	15	M 18 x 1.5 keg	36	21.0	32	12	19	27	WE-L-15-M 18x1.5-k
L	315	18	M 22 x 1.5 keg	40	23.0	36	14	24	32	WE-L-18-M 22x1.5-k

Series	Pressure PN ⁽¹⁾	Tube O.D. D1	Thread G	Approx. Dimensions						Part code
				L1	L2	L3	i	SW2	SW3	
S	630	6	M 12 x 1.5 keg	31	16.0	26	12	12	17	WE-S-06-M 12x1.5-k
S	630	8	M 14 x 1.5 keg	32	17.0	27	12	14	19	WE-S-08-M 14x1.5-k
S	630	10	M 16 x 1.5 keg	34	17.5	28	12	17	22	WE-S-10-M 16x1.5-k
S	630	12	M 18 x 1.5 keg	38	21.5	28	12	17	24	WE-S-12-M 18x1.5-k
S	630	14	M 20 x 1.5 keg	40	22.0	32	14	19	27	WE-S-14-M 20x1.5-k
S	630	16	M 22 x 1.5 keg	43	24.5	32	14	24	30	WE-S-16-M 22x1.5-k

⁽¹⁾ These pressure ratings are only valid when screwed into a taper female thread.

Fittings can be supplied with nuts with silver-plated threads to help to prevent galling, or can be supplied body only - no nut or cutting ring.

If you require silver-plated nuts, use suffix -SC. If you require body only, use suffix -OMD.

Eg. WE-L-12-M 16x1.5-k-SC, or WE-L-12-M 16x1.5-k-OMD.

Male stud coupling to metric parallel

BOOK INDEX

SECTION INDEX

to ISO 8434-1 / DIN 2353

L and S series

Form B sealing shoulder

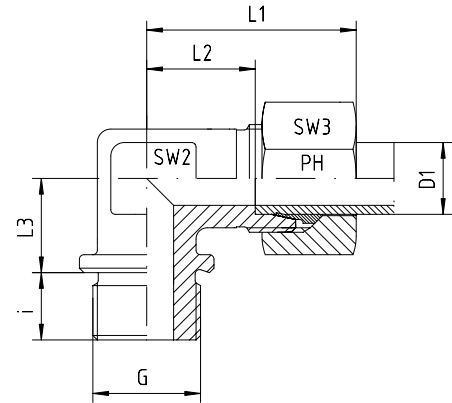

Series	Pressure PN	Tube O.D. D1	Thread G	Approx. Dimensions						Part code
				L1	L2	L3	i	SW2	SW3	
L	160	22	M 26 x 1.5 zyl	44	27.5	26	16	27	36	WE-L-22-M 26x1.5-z
L	160	28	M 33 x 2 zyl	47	30.5	30	18	36	41	WE-L-28-M 33x2-z
L	160	35	M 42 x 2 zyl	56	34.5	34	20	41	50	WE-L-35-M 42x2-z
L	160	42	M 48 x 2 zyl	63	40.0	39	22	50	60	WE-L-42-M 48x2-z

Series	Pressure PN	Tube O.D. D1	Thread G	Approx. Dimensions						Part code
				L1	L2	L3	i	SW2	SW3	
S	400	20	M 27 x 2 zyl	48	26.5	26	16	27	36	WE-S-20-M 27x2-z
S	250	25	M 33 x 2 zyl	54	30.0	30	18	36	46	WE-S-25-M 33x2-z
S	160	30	M 42 x 2 zyl	62	35.5	34	20	41	50	WE-S-30-M 42x2-z
S	160	38	M 48 x 2 zyl	72	41.0	39	22	50	60	WE-S-38-M 48x2-z

Fittings can be supplied with nuts with silver-plated threads to help to prevent galling, or can be supplied body only - no nut or cutting ring.

If you require silver-plated nuts, use suffix -SC. If you require body only, use suffix -OMD.

Eg. WE-L-22-M 25x1.5-z-SC, or WE-L-22-M 25x1.5-z-OMD.

Male stud elbow to NPT

BOOK INDEX

SECTION INDEX

to ISO 8434-1 / DIN 2353

LL and L series

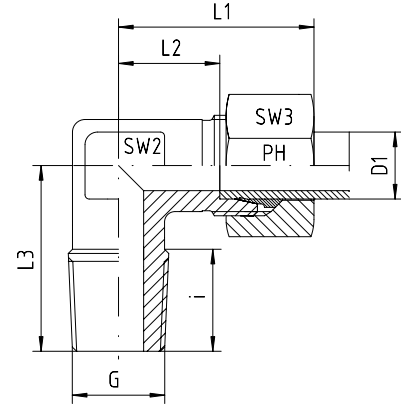

Series	Pressure PN	Tube O.D. D1	Thread G	Approx. Dimensions						Part code
				L1	L2	L3	i	SW2	SW3	
LL	100	4	1/8" NPT	21.0	11.0	17	10.0	9	10	WE-LL-04-1/8"-NPT
LL	100	6	1/8" NPT	21.0	9.5	17	10.0	9	12	WE-LL-06-1/8"-NPT
LL	100	8	1/8" NPT	23.0	11.5	20	10.0	12	14	WE-LL-08-1/8"-NPT

Series	Pressure PN	Tube O.D. D1	Thread G	Approx. Dimensions						Part number Standard
				L1	L2	L3	i	SW2	SW3	
L	315	6	1/8" NPT	27.0	12.0	20	10.0	12	14	WE-L-06-1/8"-NPT
L	315	6	1/4" NPT	29.0	14.0	26	15.0	12	14	WE-L-06-1/4"-NPT
L	315	6	3/8" NPT	33.0	18.0	28	15.3	14	14	WE-L-06-3/8"-NPT
L	315	6	1/2" NPT	30.5	15.5	30	20.0	17	14	WE-L-06-1/2"-NPT
L	315	8	1/8" NPT	29.0	14.0	26	10.0	12	17	WE-L-08-1/8"-NPT
L	315	8	1/4" NPT	29.0	14.0	26	15.0	12	17	WE-L-08-1/4"-NPT
L	315	8	3/8" NPT	29.0	14.0	26	15.3	14	17	WE-L-08-3/8"-NPT
L	315	8	1/2" NPT	34.5	19.5	30	20.0	17	17	WE-L-08-1/2"-NPT
L	315	10	1/8" NPT	30.0	15.0	27	10.0	14	19	WE-L-10-1/8"-NPT
L	315	10	1/4" NPT	30.0	15.0	27	15.0	14	19	WE-L-10-1/4"-NPT
L	315	10	3/8" NPT	32.0	17.0	28	15.3	14	19	WE-L-10-3/8"-NPT
L	315	10	1/2" NPT	37.0	21.0	33	20.0	17	19	WE-L-10-1/2"-NPT
L	315	12	1/8" NPT	32.0	17.0	28	10.0	17	22	WE-L-12-1/8"-NPT
L	315	12	1/4" NPT	32.0	17.0	28	15.0	17	22	WE-L-12-1/4"-NPT
L	315	12	3/8" NPT	32.0	17.0	28	15.3	17	22	WE-L-12-3/8"-NPT
L	315	12	1/2" NPT	36.0	21.0	34	20.0	17	22	WE-L-12-1/2"-NPT
L	315	15	3/8" NPT	36.0	21.0	34	15.3	19	27	WE-L-15-3/8"-NPT
L	315	15	1/2" NPT	36.0	21.0	34	20.0	19	27	WE-L-15-1/2"-NPT
L	160	15	3/4" NPT	36.0	21.0	42	20.0	24	27	WE-L-15-3/4"-NPT
L	315	18	3/8" NPT	40.0	23.5	36	15.3	24	32	WE-L-18-3/8"-NPT
L	315	18	1/2" NPT	40.0	23.5	36	20.0	24	32	WE-L-18-1/2"-NPT
L	160	18	3/4" NPT	38.5	22.0	41	20.0	24	32	WE-L-18-3/4"-NPT
L	160	22	1/2" NPT	44.0	27.5	42	20.0	27	36	WE-L-22-1/2"-NPT
L	160	22	3/4" NPT	44.0	27.5	42	20.0	27	36	WE-L-22-3/4"-NPT
L	160	28	3/4" NPT	47.0	30.5	48	20.0	36	41	WE-L-28-3/4"-NPT
L	160	28	1" NPT	47.0	30.5	48	25.0	36	41	WE-L-28-1"-NPT
L	160	35	1 1/4" NPT	56.0	34.5	54	25.5	41	50	WE-L-35-1 1/4"-NPT
L	160	42	1 1/2" NPT	63.0	40.0	61	26.0	50	60	WE-L-42-1 1/2"-NPT

Male stud elbow to NPT

BOOK INDEX

SECTION INDEX

to ISO 8434-1 / DIN 2353

S series

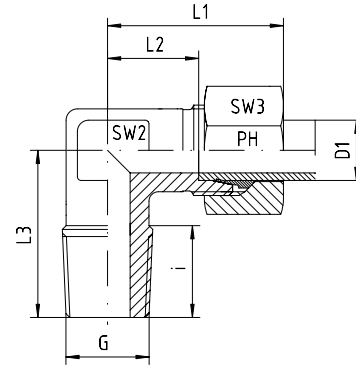

Series	Pressure PN	Tube O.D. D1	Thread G	Approx. Dimensions						Part code
				L1	L2	L3	i	SW2	SW3	
S	630	6	1/4" NPT	31	16.0	26	15.0	12	17	WE-S-06-1/4"-NPT
S	630	6	3/8" NPT	32	17.5	27	15.3	14	17	WE-S-06-3/8"-NPT
S	630	6	1/2" NPT	36	21.0	34	20.0	17	17	WE-S-06-1/2"-NPT
S	630	8	1/4" NPT	32	17.0	27	15.0	14	19	WE-S-08-1/4"-NPT
S	630	8	3/8" NPT	33	18.0	28	15.3	14	19	WE-S-08-3/8"-NPT
S	630	8	1/2" NPT	38	23.0	34	20.0	17	19	WE-S-08-1/2"-NPT
S	630	10	1/4" NPT	34	17.5	28	15.0	17	22	WE-S-10-1/4"-NPT
S	630	10	3/8" NPT	34	17.5	28	15.3	17	22	WE-S-10-3/8"-NPT
S	630	10	1/2" NPT	39	22.5	32	20.0	17	22	WE-S-10-1/2"-NPT
S	630	12	1/4" NPT	38	21.5	29	15.0	17	24	WE-S-12-1/4"-NPT
S	630	12	3/8" NPT	38	21.5	28	15.3	17	24	WE-S-12-3/8"-NPT
S	630	12	1/2" NPT	39	21.5	34	20.0	17	24	WE-S-12-1/2"-NPT
S	630	14	3/8" NPT	40	22.0	30	15.3	19	27	WE-S-14-3/8"-NPT
S	630	14	1/2" NPT	40	22.0	34	20.0	19	27	WE-S-14-1/2"-NPT
S	400	16	3/8" NPT	43	24.5	32	15.3	24	30	WE-S-16-3/8"-NPT
S	400	16	1/2" NPT	43	24.5	36	20.0	24	30	WE-S-16-1/2"-NPT
S	400	16	3/4" NPT	43	24.5	41	20.0	24	30	WE-S-16-3/4"-NPT
S	400	20	1/2" NPT	48	26.5	42	20.0	27	36	WE-S-20-1/2"-NPT
S	400	20	3/4" NPT	48	26.5	42	20.0	27	36	WE-S-20-3/4"-NPT
S	400	25	1" NPT	54	30.0	48	25.0	36	46	WE-S-25-1"-NPT
S	400	30	1 1/4" NPT	62	35.5	54	25.5	41	50	WE-S-30-1 1/4"-NPT
S	315	38	1 1/2" NPT	72	41.0	61	26.0	50	60	WE-S-38-1 1/2"-NPT

Fittings can be supplied with nuts with silver-plated threads to help to prevent galling, or can be supplied body only - no nut or cutting ring.

If you require silver-plated nuts, use suffix -SC. If you require body only, use suffix -OMD.

Eg. WE-S-12-3/8"-NPT-SC, or WE-S-12-3/8"-NPT-OMD.

Male stud branch tee to BSP taper

BOOK INDEX

SECTION INDEX

to ISO 8434-1 / DIN 2353

LL, L and S series

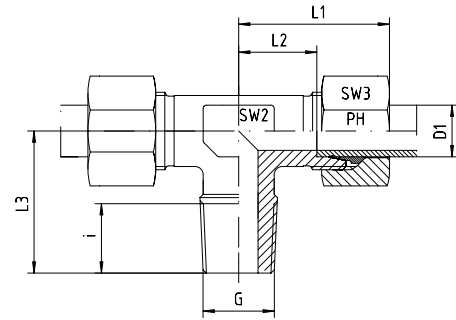
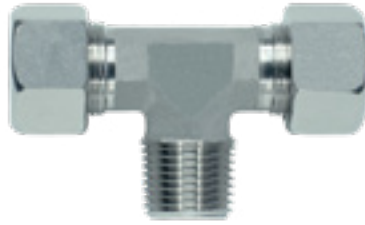

Series	Pressure PN	Tube O.D. D1	Thread G	Approx. Dimensions						Part code
				L1	L2	L3	i	SW2	SW3	
LL	100	4	R 1/8" keg	21	11.0	17	8	9	10	TE-LL-04-R 1/8"-k
LL	100	6	R 1/8" keg	21	9.5	17	8	9	12	TE-LL-06-R 1/8"-k
LL	100	8	R 1/8" keg	23	11.5	20	8	12	14	TE-LL-08-R 1/8"-k

Series	Pressure PN	Tube O.D. D1	Thread G	Approx. Dimensions						Part number Standard
				L1	L2	L3	i	SW2	SW3	
L	315	6	R 1/8" keg	27	12.0	20	8	12	14	TE-L-06-R 1/8"-k
L	315	6	R 1/4" keg	29	14.0	26	12	12	14	TE-L-06-R 1/4"-k
L	315	8	R 1/4" keg	29	14.0	26	12	12	17	TE-L-08-R 1/4"-k
L	315	8	R 3/8" keg	30	15.0	28	12	14	17	TE-L-08-R 3/8"-k
L	315	10	R 1/8" keg				8	14	19	TE-L-10-R 1/8"-k
L	315	10	R 1/4" keg	30	15.0	27	12	14	19	TE-L-10-R 1/4"-k
L	315	10	R 3/8" keg	30	15.0	27	12	17	19	TE-L-10-R 3/8"-k
L	315	10	R 1/2" keg	37	21.0	33	14	17	19	TE-L-10-R 1/2"-k
L	315	12	R 1/4" keg	32	17.0	28	12	17	22	TE-L-12-R 1/4"-k
L	315	12	R 3/8" keg	32	17.0	28	12	17	22	TE-L-12-R 3/8"-k
L	315	12	R 1/2" keg	38	20.5	34	14	17	22	TE-L-12-R 1/2"-k
L	315	15	R 3/8" keg	36	21.0	34	12	19	27	TE-L-15-R 3/8"-k
L	315	15	R 1/2" keg	36	21.0	34	14	19	27	TE-L-15-R 1/2"-k
L	315	18	R 1/2" keg	40	23.5	36	14	24	32	TE-L-18-R 1/2"-k

Series	Pressure PN ⁽¹⁾	Tube O.D. D1	Thread G	Approx. Dimensions						Part code
				L1	L2	L3	i	SW2	SW3	
S	630	6	R 1/4" keg	31	16.0	26	12	12	17	TE-S-06-R 1/4"-k
S	630	8	R 1/4" keg	32	17.0	27	12	14	19	TE-S-08-R 1/4"-k
S	630	10	R 3/8" keg	34	17.5	28	12	17	22	TE-S-10-R 3/8"-k
S	630	12	R 3/8" keg	38	21.5	28	12	17	24	TE-S-12-R 3/8"-k
S	630	12	R 1/2" keg	38	21.5	34	14	19	24	TE-S-12-R 1/2"-k
S	630	14	R 1/2" keg	40	22.0	32	14	19	27	TE-S-14-R 1/2"-k
S	400	16	R 1/2" keg	43	24.5	32	14	24	30	TE-S-16-R 1/2"-k

⁽¹⁾ These pressure ratings are only valid when screwed into a taper female thread.

Fittings can be supplied with nuts with silver-plated threads to help to prevent galling, or can be supplied body only - no nut or cutting ring.

If you require silver-plated nuts, use suffix -SC. If you require body only, use suffix -OMD.

Eg. TE-L-12-R 3/8"-k-SC, or TE-L-12-R 3/8"-k-OMD.

Male stud branch tee to BSP parallel

BOOK INDEX

SECTION INDEX

to ISO 8434-1 / DIN 2353

L and S series

Form B sealing shoulder

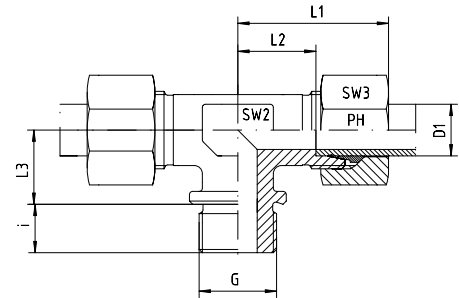

Series	Pressure PN	Tube O.D. D1	Thread G	Approx. Dimensions						Part code
				L1	L2	L3	i	SW2	SW3	
L	160	22	G 3/4" zyl	44	27.5	26	16	27	36	TE-L-22-R 3/4"-z
L	160	28	G 1" zyl	47	30.5	30	18	36	41	TE-L-28-R 1"-z
L	160	35	G 1 1/4" zyl	56	34.5	34	20	41	50	TE-L-35-R 1 1/4"-z
L	160	42	G 1 1/2" zyl	63	40.0	39	22	50	60	TE-L-42-R 1 1/2"-z

Series	Pressure PN	Tube O.D. D1	Thread G	Approx. Dimensions						Part code
				L1	L2	L3	i	SW2	SW3	
S	400	20	G 3/4" zyl	48	26.5	26	16	27	36	TE-S-20-R 3/4"-z
S	250	25	G 1" zyl	54	30.0	30	18	36	46	TE-S-25-R 1"-z
S	160	30	G 1 1/4" zyl	62	35.5	34	20	41	50	TE-S-30-R 1 1/4"-z
S	160	38	G 1 1/2" zyl	72	41.0	39	22	50	60	TE-S-38-R 1 1/2"-z

Fittings can be supplied with nuts with silver-plated threads to help to prevent galling, or can be supplied body only - no nut or cutting ring.

If you require silver-plated nuts, use suffix -SC. If you require body only, use suffix -OMD.

Eg. TE-L-22-R 3/4"-z-SC, or TE-L-22-R 3/4"-z-SC.

Male stud branch tee to metric taper

BOOK INDEX

SECTION INDEX

to ISO 8434-1 / DIN 2353

LL, L and S series

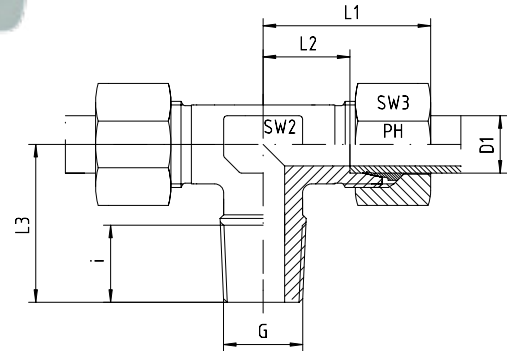

Series	Pressure PN	Tube O.D. D1	Thread G	Approx. Dimensions						Part code
				L1	L2	L3	i	SW2	SW3	
LL	100	4	M 6 x 1 keg	21	11.0	17	8	9	10	TE-LL-04-M 6x1-k
LL	100	4	M 8 x 1 keg	21	11.0	17	8	9	10	TE-LL-04-M 8x1-k
LL	100	6	M 6 x 1 keg	21	9.5	17	8	9	12	TE-LL-06-M 6x1-k
LL	100	6	M 8 x 1 keg	21	9.5	17	8	9	12	TE-LL-06-M 8x1-k
LL	100	6	M 10 x 1 keg	21	9.5	17	8	9	12	TE-LL-06-M 10x1-k
LL	100	8	M 8 x 1 keg	23	11.5	20	8	12	14	TE-LL-08-M 8x1-k
LL	100	8	M 10 x 1 keg	23	11.5	20	8	12	14	TE-LL-08-M 10x1-k

Series	Pressure PN	Tube O.D. D1	Thread G	Approx. Dimensions						Part code
				L1	L2	L3	i	SW2	SW3	
L	315	6	M 10 x 1 keg	27	12.0	20	8	12	14	TE-L-06-M 10x1-k
L	315	8	M 12 x 1.5 keg	29	14.0	26	12	12	17	TE-L-08-M 12x1.5-k
L	315	10	M 14 x 1.5 keg	30	15.0	27	12	14	19	TE-L-10-M 14x1.5-k
L	315	12	M 16 x 1.5 keg	32	17.0	28	12	17	22	TE-L-12-M 16x1.5-k
L	315	15	M 18 x 1.5 keg	36	21.0	32	12	19	27	TE-L-15-M 18x1.5-k
L	315	18	M 22 x 1.5 keg	40	23.5	36	14	24	32	TE-L-18-M 22x1.5-k

Series	Pressure PN ⁽¹⁾	Tube O.D. D1	Thread G	Approx. Dimensions						Part code
				L1	L2	L3	i	SW2	SW3	
S	630	6	M 12 x 1.5 keg	31	16.0	26	12	12	17	TE-S-06-M 12x1.5-k
S	630	8	M 14 x 1.5 keg	32	17.0	27	12	14	19	TE-S-08-M 14x1.5-k
S	630	10	M 16 x 1.5 keg	34	17.5	28	12	17	22	TE-S-10-M 16x1.5-k
S	630	12	M 18 x 1.5 keg	38	21.5	28	12	17	24	TE-S-12-M 18x1.5-k
S	630	14	M 20 x 1.5 keg	40	22.0	32	14	17	27	TE-S-14-M 20x1.5-k
S	400	16	M 22 x 1.5 keg	43	24.5	32	14	19	30	TE-S-16-M 22x1.5-k

⁽¹⁾ These pressure ratings are only valid when screwed into a taper female thread.

Fittings can be supplied with nuts with silver-plated threads to help to prevent galling, or can be supplied body only - no nut or cutting ring.

If you require silver-plated nuts, use suffix -SC. If you require body only, use suffix -OMD.

Eg. TE-L-12-M 16x1.5-k-SC, or TE-L-12-M 16x1.5-k-OMD.

Male stud branch tee to metric parallel

BOOK INDEX

SECTION INDEX

to ISO 8434-1 / DIN 2353

L and S series

Form B sealing shoulder

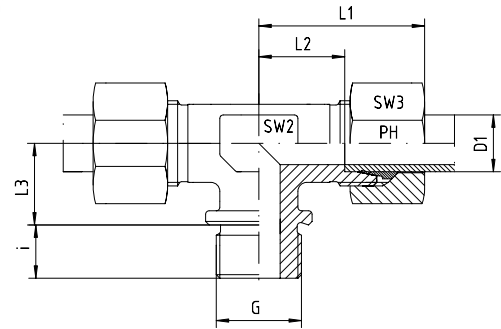

Series	Pressure PN	Tube O.D. D1	Thread G	Approx. Dimensions						Part code
				L1	L2	L3	i	SW2	SW3	
L	160	22	M 26 x 1.5 zyl	44	27.5	26	16	27	36	TE-L-22-M 26x1.5-z
L	160	28	M 33 x 2 zyl	47	30.5	30	18	36	41	TE-L-28-M 33x2-z
L	160	35	M 42 x 2 zyl	56	34.5	34	20	41	50	TE-L-35-M 42x2-z
L	160	42	M 48 x 2 zyl	63	40.0	39	22	50	60	TE-L-42-M 48x2-z

Series	Pressure PN	Tube O.D. D1	Thread G	Approx. Dimensions						Part code
				L1	L2	L3	i	SW2	SW3	
S	400	20	M 27 x 2 zyl	48	26.5	26	16	27	36	TE-S-20-M 27x2-z
S	250	25	M 33 x 2 zyl	54	30.0	30	18	36	46	TE-S-25-M 33x2-z
S	160	30	M 42 x 2 zyl	62	35.5	34	20	41	50	TE-S-30-M 42x2-z
S	160	38	M 48 x 2 zyl	72	41.0	39	22	50	60	TE-S-38-M 48x2-z

Fittings can be supplied with nuts with silver-plated threads to help to prevent galling, or can be supplied body only - no nut or cutting ring.

If you require silver-plated nuts, use suffix -SC. If you require body only, use suffix -OMD.

Eg. TE-L-22-M 26x1.5-k-SC, or TE-L-22-M 26x1.5-k-SC.

Male stud branch tee to NPT

BOOK INDEX

SECTION INDEX

to ISO 8434-1 / DIN 2353

LL, L and S series

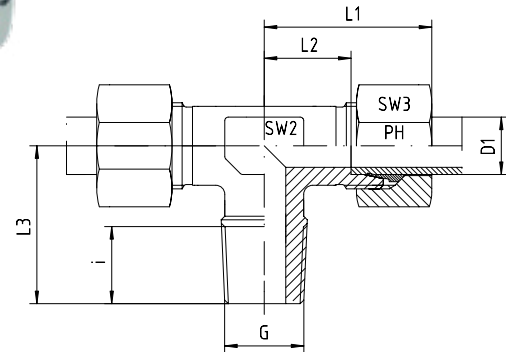

Series	Pressure PN	Tube O.D. D1	Thread G	Approx. Dimensions						Part code
				L1	L2	L3	i	SW2	SW3	
LL	100	4	1/8" NPT	21	11.0	17.0	10.0	9	10	TE-LL-04-1/8"-NPT
LL	100	6	1/8" NPT	21	9.5	17.0	10.0	9	12	TE-LL-06-1/8"-NPT
LL	100	8	1/8" NPT	23	11.5	20.0	10.0	12	14	TE-LL-08-1/8"-NPT

Series	Pressure PN	Tube O.D. D1	Thread G	Approx. Dimensions						Part code
				L1	L2	L3	i	SW2	SW3	
L	315	6	1/8" NPT	27	12.0	20.0	10.0	12	14	TE-L-06-1/8"-NPT
L	315	6	1/4" NPT	27	12.0	25.0	15.0	12	14	TE-L-06-1/4"-NPT
L	315	8	1/4" NPT	29	14.0	26.0	15.0	12	17	TE-L-08-1/4"-NPT
L	315	10	1/4" NPT	30	15.0	27.0	15.0	14	19	TE-L-10-1/4"-NPT
L	315	10	3/8" NPT	30	15.0	27.5	15.3	14	19	TE-L-10-3/8"-NPT
L	315	10	1/2" NPT	37	21.0	33.0	20.0	17	19	TE-L-10-1/2"-NPT
L	315	12	1/4" NPT	32	17.0	28.0	15.0	17	22	TE-L-12-1/4"-NPT
L	315	12	3/8" NPT	32	17.0	28.0	15.3	17	22	TE-L-12-3/8"-NPT
L	315	12	1/2" NPT	36	21.0	34.0	20.0	17	22	TE-L-12-1/2"-NPT
L	315	15	3/8" NPT	36	21.0	34.0	15.3	19	27	TE-L-15-3/8"-NPT
L	315	15	1/2" NPT	36	21.0	34.0	20.0	19	27	TE-L-15-1/2"-NPT
L	315	18	1/2" NPT	40	23.5	36.0	20.0	24	32	TE-L-18-1/2"-NPT
L	160	22	3/4" NPT	44	27.5	42.0	20.0	27	36	TE-L-22-3/4"-NPT
L	160	28	1" NPT	47	30.5	48.0	25.0	36	41	TE-L-28-1"-NPT
L	160	35	1 1/4" NPT	56	34.5	54.0	25.5	41	50	TE-L-35-1 1/4"-NPT
L	160	42	1 1/2" NPT	63	40.0	61.0	26.0	50	60	TE-L-42-1 1/2"-NPT

Series	Pressure PN	Tube O.D. D1	Thread G	Approx. Dimensions						Part code
				L1	L2	L3	i	SW2	SW3	
S	630	6	1/4" NPT	31	16.0	26.0	15.0	12	17	TE-S-06-1/4"-NPT
S	630	8	1/4" NPT	32	17.0	27.0	15.0	14	19	TE-S-08-1/4"-NPT
S	630	10	1/4" NPT	34	17.5	28.0	15.0	17	22	TE-S-10-1/4"-NPT
S	630	10	3/8" NPT	34	17.5	28.0	15.3	17	22	TE-S-10-3/8"-NPT
S	630	10	1/2" NPT				20.0	17	22	TE-S-10-1/2"-NPT
S	630	12	1/4" NPT	38	21.5	29.0	15.0	17	24	TE-S-12-1/4"-NPT
S	630	12	3/8" NPT	38	21.5	28.0	15.3	17	24	TE-S-12-3/8"-NPT
S	630	12	1/2" NPT	39	21.5	34.0	20.0	19	24	TE-S-12-1/2"-NPT
S	630	14	1/2" NPT	40	22.0	34.0	20.0	19	27	TE-S-14-1/2"-NPT
S	400	16	1/2" NPT	43	24.5	36.0	20.0	24	30	TE-S-16-1/2"-NPT
S	400	20	3/4" NPT	48	26.5	42.0	20.0	27	36	TE-S-20-3/4"-NPT
S	400	25	1" NPT	54	30.0	48.0	25.0	36	46	TE-S-25-1"-NPT
S	400	30	1 1/4" NPT	62	35.5	54.0	25.5	41	50	TE-S-30-1 1/4"-NPT
S	315	38	1 1/2" NPT	72	41.0	61.0	26.0	50	60	TE-S-38-1 1/2"-NPT

to ISO 8434-1 / DIN 2353

LL, L and S series

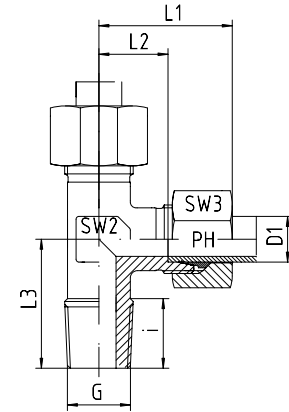

Series	Pressure PN	Tube O.D. D1	Thread G	Approx. Dimensions						Part code
				L1	L2	L3	i	SW2	SW3	
LL	100	4	R 1/8" keg	21	11.0	17	8	9	10	LE-LL-04-R 1/8"-k
LL	100	6	R 1/8" keg	21	9.5	17	8	9	12	LE-LL-06-R 1/8"-k
LL	100	8	R 1/8" keg	23	11.5	20	8	12	14	LE-LL-08-R 1/8"-k

Series	Pressure PN	Tube O.D. D1	Thread G	Approx. Dimensions						Part code
				L1	L2	L3	i	SW2	SW3	
L	315	6	R 1/8" keg	27	12.0	20	8	12	14	LE-L-06-R 1/8"-k
L	315	6	R 1/4" keg	27	12.0	26	12	12	14	LE-L-06-R 1/4"-k
L	315	8	R 1/4" keg	29	14.0	26	12	12	17	LE-L-08-R 1/4"-k
L	315	8	R 3/8" keg	32	17.0	28	12	14	17	LE-L-08-R 3/8"-k
L	315	10	R 1/8" keg				8	14	19	LE-L-10-R 1/8"-k
L	315	10	R 1/4" keg	30	15.0	27	12	14	19	LE-L-10-R 1/4"-k
L	315	10	R 3/8" keg	30	15.0	28	12	17	19	LE-L-10-R 3/8"-k
L	315	10	R 1/2" keg				14	17	19	LE-L-10-R 1/2"-k
L	315	12	R 1/4" keg	32	17.5	27	12	17	22	LE-L-12-R 1/4"-k
L	315	12	R 3/8" keg	32	17.5	28	12	17	22	LE-L-12-R 3/8"-k
L	315	12	R 1/2" keg				14	17	22	LE-L-12-R 1/2"-k
L	315	15	R 3/8" keg				12	19	27	LE-L-15-R 3/8"-k
L	315	15	R 1/2" keg	36	21.0	34	14	19	27	LE-L-15-R 1/2"-k
L	315	18	R 1/2" keg	40	23.5	36	14	24	32	LE-L-18-R 1/2"-k

Series	Pressure PN ⁽¹⁾	Tube O.D. D1	Thread G	Approx. Dimensions						Part code
				L1	L2	L3	i	SW2	SW3	
S	630	6	R 1/4" keg	31	16.5	26	12	12	17	LE-S-06-R 1/4"-k
S	630	8	R 1/4" keg	32	17.0	27	12	14	19	LE-S-08-R 1/4"-k
S	630	10	R 3/8" keg	34	17.5	28	12	17	22	LE-S-10-R 3/8"-k
S	630	12	R 3/8" keg	38	21.5	28	12	17	24	LE-S-12-R 3/8"-k
S	630	12	R 1/2" keg	38	21.5	33	14	19	24	LE-S-12-R 1/2"-k
S	630	14	R 1/2" keg	40	22.0	32	14	19	27	LE-S-14-R 1/2"-k
S	400	16	R 1/2" keg	43	24.5	32	14	24	30	LE-S-16-R 1/2"-k

⁽¹⁾ These pressure ratings are only valid when screwed into a taper female thread.

Fittings can be supplied with nuts with silver-plated threads to help to prevent galling, or can be supplied body only - no nut or cutting ring.

If you require silver-plated nuts, use suffix -SC. If you require body only, use suffix -OMD.

Eg. LE-L-12-M 16x1.5-k-SC, or LE-L-12-M 16x1.5-k-OMD.

Male stud run tee to BSP parallel

BOOK INDEX

SECTION INDEX

to ISO 8434-1 / DIN 2353

L and S series

Form B sealing shoulder

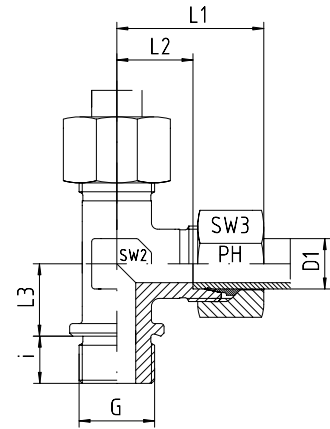
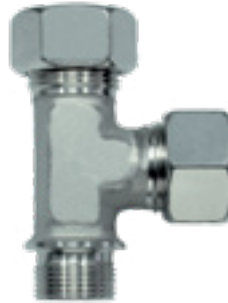

Series	Pressure PN	Tube O.D. D1	Thread G	Approx. Dimensions						Part code
				L1	L2	L3	i	SW2	SW3	
L	160	22	G 3/4" zyl	44	27.5	26	16	27	36	LE-L-22-R 3/4"-z
L	160	28	G 1" zyl	47	30.5	30	18	36	41	LE-L-28-R 1"-z
L	160	35	G 1 1/4" zyl	56	34.5	34	20	41	50	LE-L-35-R 1 1/4"-z
L	160	42	G 1 1/2" zyl	63	40.0	39	22	50	60	LE-L-42-R 1 1/2"-z

Series	Pressure PN	Tube O.D. D1	Thread G	Approx. Dimensions						Part code
				L1	L2	L3	i	SW2	SW3	
S	400	20	G 3/4" zyl	48	26.5	26	16	27	36	LE-S-20-R 3/4"-z
S	250	25	G 1" zyl	54	30.0	30	18	36	46	LE-S-25-R 1"-z
S	160	30	G 1 1/4" zyl	62	35.5	34	20	41	50	LE-S-30-R 1 1/4"-z
S	160	38	G 1 1/2" zyl	72	41.0	39	22	50	60	LE-S-38-R 1 1/2"-z

Fittings can be supplied with nuts with silver-plated threads to help to prevent galling, or can be supplied body only - no nut or cutting ring.

If you require silver-plated nuts, use suffix -SC. If you require body only, use suffix -OMD.

Eg. LE-L-22-R 3/4"-z-SC, or LE-L-22-R 3/4"-z-OMD

Male stud run tee to metric taper

BOOK INDEX

SECTION INDEX

to ISO 8434-1 / DIN 2353

LL, L and S series

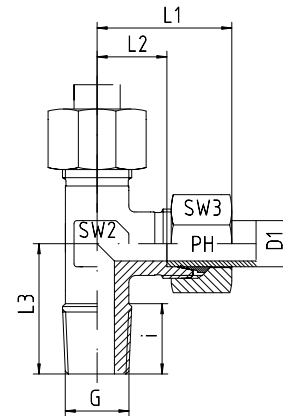

Series	Pressure PN	Tube O.D. D1	Thread G	Approx. Dimensions						Part code
				L1	L2	L3	i	SW2	SW3	
LL	100	4	M 6 x 1 keg	21	11.0	17	8	9	10	LE-LL-04-M 6x1-k
LL	100	4	M 8 x 1 keg	21	11.0	17	8	9	10	LE-LL-04-M 8x1-k
LL	100	6	M 6 x 1 keg				8	9	12	LE-LL-06-M 6x1-k
LL	100	6	M 8 x 1 keg				8	9	12	LE-LL-06-M 8x1-k
LL	100	6	M 10 x 1 keg	21	9.5	17	8	9	12	LE-LL-06-M 10x1-k
LL	100	8	M 8 x 1 keg				8	12	14	LE-LL-08-M 8x1-k
LL	100	8	M 10 x 1 keg	23	11.5	20	8	12	14	LE-LL-08-M 10x1-k

Series	Pressure PN	Tube O.D. D1	Thread G	Approx. Dimensions						Part code
				L1	L2	L3	i	SW2	SW3	
L	315	6	M 10 x 1 keg	27	12.0	20	8	12	14	LE-L-06-M 10x1-k
L	315	8	M 12 x 1.5 keg	29	14.0	26	12	12	17	LE-L-08-M 12x1.5-k
L	315	10	M 14 x 1.5 keg	30	15.0	27	12	14	19	LE-L-10-M 14x1.5-k
L	315	12	M 16 x 1.5 keg	32	17.0	28	12	17	22	LE-L-12-M 16x1.5-k
L	315	15	M 18 x 1.5 keg	36	21.0	32	12	19	27	LE-L-15-M 18x1.5-k
L	315	18	M 22 x 1.5 keg	40	23.0	36	14	24	32	LE-L-18-M 22x1.5-k

Series	Pressure PN ⁽¹⁾	Tube O.D. D1	Thread G	Approx. Dimensions						Part code
				L1	L2	L3	i	SW2	SW3	
S	630	6	M 12 x 1.5 keg	31	16.0	26	12	12	17	LE-S-06-M 12x1.5-k
S	630	8	M 14 x 1.5 keg	32	17.0	27	12	14	19	LE-S-08-M 14x1.5-k
S	630	10	M 16 x 1.5 keg	34	17.5	28	12	17	22	LE-S-10-M 16x1.5-k
S	630	12	M 18 x 1.5 keg	38	21.5	28	12	17	24	LE-S-12-M 18x1.5-k
S	630	14	M 20 x 1.5 keg	40	22.0	32	14	19	27	LE-S-14-M 20x1.5-k
S	400	16	M 22 x 1.5 keg	43	24.5	32	14	24	30	LE-S-16-M 22x1.5-k

⁽¹⁾ These pressure ratings are only valid when screwed into a taper female thread.

Fittings can be supplied with nuts with silver-plated threads to help to prevent galling, or can be supplied body only - no nut or cutting ring.

If you require silver-plated nuts, use suffix -SC. If you require body only, use suffix -OMD.

Eg. LE-L-12-M 16x1.5-k-SC, or LE-L-12-M 16x1.5-k-OMD

Male stud run tee to metric parallel

BOOK INDEX

SECTION INDEX

to ISO 8434-1 / DIN 2353

L and S series

Form B sealing shoulder

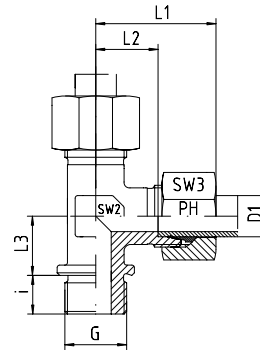

Series	Pressure PN	Tube O.D. D1	Thread G	Approx. Dimensions						Part code
				L1	L2	L3	i	SW2	SW3	
L	160	22	M 26 x 1.5 zyl	44	27.5	26	16	27	36	LE-L-22-M 26x1.5-z
L	160	28	M 33 x 2 zyl	47	30.5	30	18	36	41	LE-L-28-M 33x2-z
L	160	35	M 42 x 2 zyl	56	34.5	34	20	41	50	LE-L-35-M 42x2-z
L	160	42	M 48 x 2 zyl	63	40.0	39	22	50	60	LE-L-42-M 48x2-z

Series	Pressure PN	Tube O.D. D1	Thread G	Approx. Dimensions						Part code
				L1	L2	L3	i	SW2	SW3	
S	400	20	M 27 x 2 zyl	48	26.5	26	16	27	36	LE-S-20-M 27x2-z
S	250	25	M 33 x 2 zyl	54	30.0	30	18	36	46	LE-S-25-M 33x2-z
S	160	30	M 42 x 2 zyl	62	35.5	34	20	41	50	LE-S-30-M 42x2-z
S	160	38	M 48 x 2 zyl	72	41.0	39	22	50	60	LE-S-38-M 48x2-z

Fittings can be supplied with nuts with silver-plated threads to help to prevent galling, or can be supplied body only - no nut or cutting ring.

If you require silver-plated nuts, use suffix -SC. If you require body only, use suffix -OMD.

Eg. LE-L-22-M 26x1.5-z-SC, or LE-L-22-M 26x1.5-z-OMD

Male stud run tee to NPT

BOOK INDEX

SECTION INDEX

to ISO 8434-1 / DIN 2353

LL, L and S series

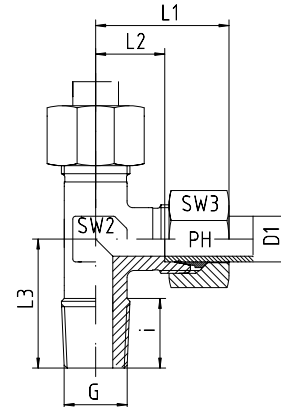

Series	Pressure PN	Tube O.D. D1	Thread G	Approx. Dimensions						Part code
				L1	L2	L3	i	SW2	SW3	
LL	100	4	1/8" NPT	21	11.0	17	10.0	9	10	LE-LL-04-1/8"-NPT
LL	100	6	1/8" NPT	21	9.5	17	10.0	9	14	LE-LL-06-1/8"-NPT
LL	100	8	1/8" NPT	23	11.5	20	10.0	12	17	LE-LL-08-1/8"-NPT

Series	Pressure PN	Tube O.D. D1	Thread G	Approx. Dimensions						Part code
				L1	L2	L3	i	SW2	SW3	
L	315	6	1/8" NPT	27	12.0	20	10.0	12	14	LE-L-06-1/8"-NPT
L	315	6	1/4" NPT	29	14.0	26	15.0	12	14	LE-L-06-1/4"-NPT
L	315	8	1/4" NPT	29	14.0	26	15.0	12	17	LE-L-08-1/4"-NPT
L	315	10	1/4" NPT	30	15.0	27	15.0	14	19	LE-L-10-1/4"-NPT
L	315	10	3/8" NPT				15.3	17	19	LE-L-10-3/8"-NPT
L	315	10	1/2" NPT				20.0	17	19	LE-L-10-1/2"-NPT
L	315	12	1/4" NPT	32	17.0	28	15.0	17	22	LE-L-12-1/4"-NPT
L	315	12	3/8" NPT	32	17.0	28	15.3	17	22	LE-L-12-3/8"-NPT
L	315	12	1/2" NPT				20.0	17	22	LE-L-12-1/2"-NPT
L	315	15	3/8" NPT				15.3	19	27	LE-L-15-3/8"-NPT
L	315	15	1/2" NPT	36	21.0	34	20.0	19	27	LE-L-15-1/2"-NPT
L	315	18	1/2" NPT	40	23.5	36	20.0	24	32	LE-L-18-1/2"-NPT
L	160	22	3/4" NPT	44	27.5	42	20.0	27	36	LE-L-22-3/4"-NPT
L	160	28	1" NPT	47	30.5	48	25.0	36	41	LE-L-28-1"-NPT
L	160	35	1 1/4" NPT	56	34.5	54	25.5	41	50	LE-L-35-1 1/4"-NPT
L	160	42	1 1/2" NPT	63	40.0	61	26.0	50	60	LE-L-42-1 1/2"-NPT

Series	Pressure PN	Tube O.D. D1	Thread G	Approx. Dimensions						Part code
				L1	L2	L3	i	SW2	SW3	
S	630	6	1/4" NPT	31	16.0	26	15.0	12	17	LE-S-06-1/4"-NPT
S	630	8	1/4" NPT	32	17.0	27	15.0	14	19	LE-S-08-1/4"-NPT
S	630	10	1/4" NPT				15.0	17	22	LE-S-10-1/4"-NPT
S	630	10	3/8" NPT	34	17.5	28	15.3	17	22	LE-S-10-3/8"-NPT
S	630	10	1/2" NPT				20.0	17	22	LE-S-10-1/2"-NPT
S	630	12	1/4" NPT				15.0	17	24	LE-S-12-1/4"-NPT
S	630	12	3/8" NPT	38	21.5	28	15.3	17	24	LE-S-12-3/8"-NPT
S	630	12	1/2" NPT	38	21.5	33	20.0	19	24	LE-S-12-1/2"-NPT
S	630	14	1/2" NPT	40	22.0	34	20.0	19	27	LE-S-14-1/2"-NPT
S	400	16	1/2" NPT	43	24.5	36	20.0	24	30	LE-S-16-1/2"-NPT
S	400	20	3/4" NPT	48	26.5	42	20.0	27	36	LE-S-20-3/4"-NPT
S	400	25	1" NPT	54	30.0	48	25.0	36	46	LE-S-25-1"-NPT
S	400	30	1 1/4" NPT	62	35.5	54	25.5	41	50	LE-S-30-1 1/4"-NPT
S	315	38	1 1/2" NPT	72	41.0	61	26.0	50	60	LE-S-38-1 1/2"-NPT



24° compression fittings to ISO 8434-1 / DIN 2354

Standpipe to BSP parallel male - body only

BOOK INDEX

SECTION INDEX

These fittings are supplied without the nut and cutting ring pre-installed.

The male BSP parallel thread has an elastomeric Viton soft seal.

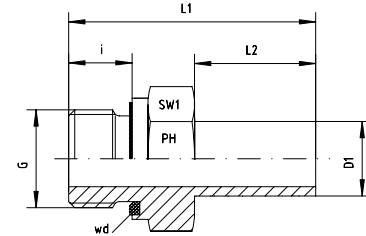

Series	Pressure PN	Tube O.D. D1	Thread G	Approx. Dimensions				Part code
				L1	L2	i	SW1	
L	315	6	G 1/8"	32.5	19.0	8	14	EVGE-L-06-G 1/8"-ov-wd
L	315	6	G 1/4"	39.5	20.5	12	19	EVGE-L-06-G 1/4"-ov-wd
L	315	8	G 1/4"	41.0	20.5	12	19	EVGE-L-08-G 1/4"-ov-wd
L	315	8	G 3/8"	42.5	20.5	12	22	EVGE-L-08-G 3/8"-ov-wd
L	315	10	G 1/4"	39.5	20.5	12	19	EVGE-L-10-G 1/4"-ov-wd
L	315	10	G 3/8"	44.0	21.0	12	22	EVGE-L-10-G 3/8"-ov-wd
L	315	10	G 1/2"	47.0	21.0	14	27	EVGE-L-10-G 1/2"-ov-wd
L	315	12	G 1/4"	42.0	21.5	12	19	EVGE-L-12-G 1/4"-ov-wd
L	315	12	G 3/8"	45.0	22.0	12	22	EVGE-L-12-G 3/8"-ov-wd
L	315	12	G 1/2"	48.5	22.5	14	27	EVGE-L-12-G 1/2"-ov-wd
L	315	15	G 3/8"	45.5	22.5	12	22	EVGE-L-15-G 3/8"-ov-wd
L	315	15	G 1/2"	46.0	23.0	14	27	EVGE-L-15-G 1/2"-ov-wd
L	315	18	G 3/8"	44.0	23.5	12	22	EVGE-L-18-G 3/8"-ov-wd
L	315	18	G 1/2"	47.0	24.0	14	27	EVGE-L-18-G 1/2"-ov-wd
L	160	18	G 3/4"	52.0	24.0	16	32	EVGE-L-18-G 3/4"-ov-wd
L	160	22	G 3/8"	46.0	24.5	12	24	EVGE-L-22-G 3/8"-ov-wd
L	160	22	G 1/2"	50.5	24.5	14	27	EVGE-L-22-G 1/2"-ov-wd
L	160	22	G 3/4"	50.5	24.5	16	32	EVGE-L-22-G 3/4"-ov-wd
L	160	22	G 1"	52.5	25.5	18	41	EVGE-L-22-G 1"-ov-wd
L	160	28	G 3/4"	52.5	25.5	16	32	EVGE-L-28-G 3/4"-ov-wd
L	160	28	G 1"	54.0	25.5	18	41	EVGE-L-28-G 1"-ov-wd
L	160	35	G 1 1/4"	63.5	32.0	20	50	EVGE-L-35-G 1 1/4"-ov-wd
L	160	42	G 1 1/2"	70.0	32.0	22	55	EVGE-L-42-G 1 1/2"-ov-wd

Series	Pressure PN	Tube O.D. D1	Thread G	Approx. Dimensions				Part code
				L1	L2	i	SW1	
S	630	6	G 1/8"	32.5	19.0	8	14	EVGE-S-06-G 1/8"-ov-wd
S	630	6	G 1/4"	39.5	20.5	12	19	EVGE-S-06-G 1/4"-ov-wd
S	630	8	G 1/4"	41.0	20.5	12	19	EVGE-S-08-G 1/4"-ov-wd
S	630	8	G 3/8"	42.5	20.5	12	22	EVGE-S-08-G 3/8"-ov-wd
S	630	10	G 1/4"	39.5	20.5	12	19	EVGE-S-10-G 1/4"-ov-wd
S	630	10	G 3/8"	44.0	21.0	12	22	EVGE-S-10-G 3/8"-ov-wd
S	630	10	G 1/2"	46.5	20.5	14	27	EVGE-S-10-G 1/2"-ov-wd
S	630	12	G 1/4"	42.0	21.5	12	19	EVGE-S-12-G 1/4"-ov-wd
S	630	12	G 3/8"	45.0	22.0	12	22	EVGE-S-12-G 3/8"-ov-wd
S	630	12	G 1/2"	48.5	22.5	14	27	EVGE-S-12-G 1/2"-ov-wd
S	630	14	G 1/2"	51.0	24.5	14	27	EVGE-S-14-G 1/2"-ov-wd
S	400	16	G 3/8"	48.5	26.0	12	22	EVGE-S-16-G 3/8"-ov-wd
S	400	16	G 1/2"	51.0	26.0	14	27	EVGE-S-16-G 1/2"-ov-wd
S	400	16	G 3/4"	54.5	26.0	16	32	EVGE-S-16-G 3/4"-ov-wd
S	400	20	G 1/2"	56.5	29.5	14	27	EVGE-S-20-G 1/2"-ov-wd
S	400	20	G 3/4"	59.0	29.0	16	32	EVGE-S-20-G 3/4"-ov-wd
S	400	25	G 3/4"	63.0	33.0	16	32	EVGE-S-25-G 3/4"-ov-wd
S	400	25	G 1"	66.0	33.0	18	41	EVGE-S-25-G 1"-ov-wd
S	400	30	G 1 1/4"	71.0	34.0	20	50	EVGE-S-30-G 1 1/4"-ov-wd
S	315	38	G 1 1/2"	83.5	40.0	22	55	EVGE-S-38-G 1 1/2"-ov-wd

Adjustable standpipe to BSP parallel male

BOOK INDEX

SECTION INDEX

to ISO 8434-1 / DIN 2353

L and S series

Cutting ring and nut is pre-assembled. It is necessary to tighten the nut 1/2 turn after an increase in torque is felt.

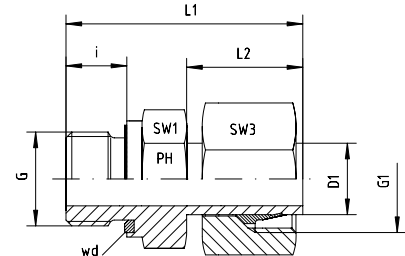

The male BSP parallel thread has an elastomeric Viton soft seal.

Series	Pressure PN	Tube O.D. D1	Thread G	Approx. Dimensions					Part code
				L1	L2	i	SW1	SW3	
L	315	6	G 1/8"	32.5	19.0	8	14	14	EVGE-L-06-G 1/8"-wd
L	315	6	G 1/4"	39.5	20.5	12	19	14	EVGE-L-06-G 1/4"-wd
L	315	8	G 1/4"	41.0	20.5	12	19	17	EVGE-L-08-G 1/4"-wd
L	315	8	G 3/8"	42.5	20.5	12	22	17	EVGE-L-08-G 3/8"-wd
L	315	10	G 1/4"	39.5	20.5	12	19	19	EVGE-L-10-G 1/4"-wd
L	315	10	G 3/8"	44.0	21.0	12	22	19	EVGE-L-10-G 3/8"-wd
L	315	10	G 1/2"	47.0	21.0	14	27	19	EVGE-L-10-G 1/2"-wd
L	315	12	G 1/4"	42.0	21.5	12	19	22	EVGE-L-12-G 1/4"-wd
L	315	12	G 3/8"	45.0	22.0	12	22	22	EVGE-L-12-G 3/8"-wd
L	315	12	G 1/2"	48.5	22.5	14	27	22	EVGE-L-12-G 1/2"-wd
L	315	15	G 3/8"	45.5	22.5	12	22	27	EVGE-L-15-G 3/8"-wd
L	315	15	G 1/2"	46.0	23.0	14	27	27	EVGE-L-15-G 1/2"-wd
L	315	18	G 3/8"	44.0	23.5	12	22	32	EVGE-L-18-G 3/8"-wd
L	315	18	G 1/2"	47.0	24.0	14	27	32	EVGE-L-18-G 1/2"-wd
L	160	18	G 3/4"	52.0	24.0	16	32	32	EVGE-L-18-G 3/4"-wd
L	160	22	G 3/8"	46.0	24.5	12	24	36	EVGE-L-22-G 3/8"-wd
L	160	22	G 1/2"	50.5	24.5	14	27	36	EVGE-L-22-G 1/2"-wd
L	160	22	G 3/4"	50.5	24.5	16	32	36	EVGE-L-22-G 3/4"-wd
L	160	22	G 1"	52.5	25.5	18	41	36	EVGE-L-22-G 1"-wd
L	160	28	G 3/4"	52.5	25.5	16	32	41	EVGE-L-28-G 3/4"-wd
L	160	28	G 1"	54.0	25.5	18	41	41	EVGE-L-28-G 1"-wd
L	160	35	G 1 1/4"	63.5	32.0	20	50	50	EVGE-L-35-G 1 1/4"-wd
L	160	42	G 1 1/2"	70.0	32.0	22	55	60	EVGE-L-42-G 1 1/2"-wd

Series	Pressure PN	Tube O.D. D1	Thread G	Approx. Dimensions					Part code
				L1	L2	i	SW1	SW3	
S	630	6	G 1/8"	32.5	19.0	8	14	17	EVGE-S-06-G 1/8"-wd
S	630	6	G 1/4"	39.5	20.5	12	19	17	EVGE-S-06-G 1/4"-wd
S	630	8	G 1/4"	41.0	20.5	12	19	19	EVGE-S-08-G 1/4"-wd
S	630	8	G 3/8"	42.5	20.5	12	22	19	EVGE-S-08-G 3/8"-wd
S	630	10	G 1/4"	39.5	20.5	12	19	22	EVGE-S-10-G 1/4"-wd
S	630	10	G 3/8"	44.0	21.0	12	22	22	EVGE-S-10-G 3/8"-wd
S	630	10	G 1/2"	47.0	21.0	14	27	22	EVGE-S-10-G 1/2"-wd
S	630	12	G 1/4"	42.0	21.5	12	19	24	EVGE-S-12-G 1/4"-wd
S	630	12	G 3/8"	45.0	22.0	12	22	24	EVGE-S-12-G 3/8"-wd
S	630	12	G 1/2"	48.5	22.5	14	27	24	EVGE-S-12-G 1/2"-wd
S	630	14	G 1/2"	51.0	24.5	14	27	27	EVGE-S-14-G 1/2"-wd
S	400	16	G 3/8"	48.5	26.0	12	22	30	EVGE-S-16-G 3/8"-wd
S	400	16	G 1/2"	51.0	26.0	14	27	30	EVGE-S-16-G 1/2"-wd
S	400	16	G 3/4"	54.5	26.0	16	32	30	EVGE-S-16-G 3/4"-wd
S	400	20	G 1/2"	56.5	29.5	14	27	36	EVGE-S-20-G 1/2"-wd
S	400	20	G 3/4"	59.0	29.0	16	32	36	EVGE-S-20-G 3/4"-wd
S	400	25	G 3/4"	63.0	33.0	16	32	46	EVGE-S-25-G 3/4"-wd
S	400	25	G 1"	66.0	33.0	18	41	46	EVGE-S-25-G 1"-wd
S	400	30	G 1 1/4"	71.0	34.0	20	50	50	EVGE-S-30-G 1 1/4"-wd
S	315	38	G 1 1/2"	83.5	40.0	22	55	60	EVGE-S-38-G 1 1/2"-wd



24° compression fittings to ISO 8434-1 / DIN 2354

Standpipe to NPT male - body only

BOOK INDEX

SECTION INDEX

These fittings are supplied without the nut and cutting ring pre-installed.

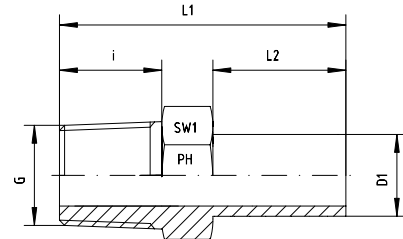
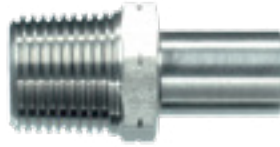

Series	Pressure PN	Tube O.D. D1	Thread G	Approx. Dimensions				Part code
				L1	L2	i	SW1	
L	315	6	1/8" NPT	32.0	19.0	10.0	12	EVGE-L-06-1/8"-ov-NPT
L	315	6	1/4" NPT	40.0	19.0	15.0	14	EVGE-L-06-1/4"-ov-NPT
L	315	8	1/4" NPT	40.5	20.0	15.0	14	EVGE-L-08-1/4"-ov-NPT
L	315	10	1/4" NPT	39.5	19.0	15.0	14	EVGE-L-10-1/4"-ov-NPT
L	315	12	1/4" NPT	42.0	22.0	15.0	14	EVGE-L-12-1/4"-ov-NPT
L	315	12	3/8" NPT	43.0	22.0	15.3	19	EVGE-L-12-3/8"-ov-NPT
L	315	12	1/2" NPT	50.0	22.0	20.0	22	EVGE-L-12-1/2"-ov-NPT
L	315	15	3/8" NPT			15.3	19	EVGE-L-15-3/8"-ov-NPT
L	315	15	1/2" NPT	48.0	22.0	20.0	22	EVGE-L-15-1/2"-ov-NPT
L	315	18	1/2" NPT	50.0	24.0	20.0	22	EVGE-L-18-1/2"-ov-NPT
L	160	22	3/4" NPT	52.0	24.5	20.0	27	EVGE-L-22-3/4"-ov-NPT
L	160	28	1" NPT	59.0	25.5	25.0	36	EVGE-L-28-1"-ov-NPT
L	160	35	1 1/4" NPT	66.0	32.0	25.5	46	EVGE-L-35-1 1/4"-ov-NPT
L	160	42	1 1/2" NPT	68.0	32.0	26.0	50	EVGE-L-42-1 1/2"-ov-NPT

Series	Pressure PN	Tube O.D. D1	Thread G	Approx. Dimensions				Part code
				L1	L2	i	SW1	
S	630	6	1/4" NPT	40.0	19.0	15.0	14	EVGE-S-06-1/4"-ov-NPT
S	630	8	1/4" NPT	40.5	20.0	15.0	14	EVGE-S-08-1/4"-ov-NPT
S	630	10	1/4" NPT	39.5	19.0	15.0	14	EVGE-S-10-1/4"-ov-NPT
S	630	10	3/8" NPT	44.0	21.0	15.3	19	EVGE-S-10-3/8"-ov-NPT
S	630	12	1/4" NPT	42.0	22.0	15.0	14	EVGE-S-12-1/4"-ov-NPT
S	630	12	3/8" NPT	43.0	22.0	15.3	19	EVGE-S-12-3/8"-ov-NPT
S	630	12	1/2" NPT	50.0	22.0	20.0	22	EVGE-S-12-1/2"-ov-NPT
S	630	14	1/2" NPT	48.0	23.5	20.0	22	EVGE-S-14-1/2"-ov-NPT
S	400	16	1/2" NPT	54.0	24.0	20.0	22	EVGE-S-16-1/2"-ov-NPT
S	400	20	3/4" NPT	58.0	28.0	20.0	27	EVGE-S-20-3/4"-ov-NPT
S	400	25	1" NPT	68.0	33.0	25.0	36	EVGE-S-25-1"-ov-NPT
S	400	30	1 1/4" NPT	73.0	33.0	25.5	46	EVGE-S-30-1 1/4"-ov-NPT
S	315	38	1 1/2" NPT	81.0	38.0	26.0	50	EVGE-S-38-1 1/2"-ov-NPT

Adjustable standpipe to NPT male

BOOK INDEX

SECTION INDEX

to ISO 8434-1 / DIN 2353

L and S series

Cutting ring and nut is pre-assembled. It is necessary to tighten the nut 1/2 turn after an increase in torque is felt.

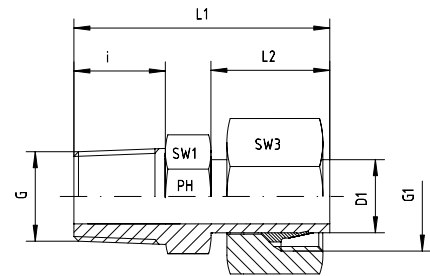
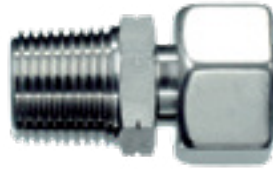

Series	Pressure PN	Tube O.D. D1	Thread		Approx. Dimensions					Part code
			G	G1	L1	L2	i	SW1	SW3	
L	315	6	1/8" NPT	M 12 x 1.5	32.0	19.0	10.0	12	14	EVGE-L-06-1/8"-NPT
L	315	6	1/4" NPT	M 12 x 1.5	40.0	19.0	15.0	14	14	EVGE-L-06-1/4"-NPT
L	315	8	1/4" NPT	M 14 x 1.5	40.5	20.0	15.0	14	17	EVGE-L-08-1/4"-NPT
L	315	10	1/4" NPT	M 16 x 1.5	39.5	19.0	15.0	14	19	EVGE-L-10-1/4"-NPT
L	315	12	1/4" NPT	M 18 x 1.5	42.0	22.0	15.0	14	22	EVGE-L-12-1/4"-NPT
L	315	12	3/8" NPT	M 18 x 1.5	43.0	22.0	15.3	19	22	EVGE-L-12-3/8"-NPT
L	315	12	1/2" NPT	M 18 x 1.5	50.0	22.0	20.0	22	22	EVGE-L-12-1/2"-NPT
L	315	15	3/8" NPT	M 22 x 1.5			15.3	19	27	EVGE-L-15-3/8"-NPT
L	315	15	1/2" NPT	M 22 x 1.5	48.0	22.0	20.0	22	27	EVGE-L-15-1/2"-NPT
L	315	18	1/2" NPT	M 26 x 1.5	50.0	24.0	20.0	22	32	EVGE-L-18-1/2"-NPT
L	160	22	3/4" NPT	M 30 x 2	52.0	24.5	20.0	27	36	EVGE-L-22-3/4"-NPT
L	160	28	1" NPT	M 36 x 2	59.0	25.5	25.0	36	41	EVGE-L-28-1"-NPT
L	160	35	1 1/4" NPT	M 45 x 2	66.0	32.0	25.5	46	50	EVGE-L-35-1 1/4"-NPT
L	160	42	1 1/2" NPT	M 52 x 2	68.0	32.0	26.0	50	60	EVGE-L-42-1 1/2"-NPT

Series	Pressure PN	Tube O.D. D1	Thread		Approx. Dimensions					Part code
			G	G1	L1	L2	i	SW1	SW3	
S	630	6	1/4" NPT	M 14 x 1.5	40.0	19.0	15.0	14	17	EVGE-S-06-1/4"-NPT
S	630	8	1/4" NPT	M 16 x 1.5	40.5	20.0	15.0	14	19	EVGE-S-08-1/4"-NPT
S	630	10	1/4" NPT	M 18 x 1.5	39.5	19.0	15.0	14	22	EVGE-S-10-1/4"-NPT
S	630	10	3/8" NPT	M 18 x 1.5	44.0	21.0	15.3	19	22	EVGE-S-10-3/8"-NPT
S	630	12	1/4" NPT	M 20 x 1.5	42.0	22.0	15.0	14	24	EVGE-S-12-1/4"-NPT
S	630	12	3/8" NPT	M 20 x 1.5	43.0	22.0	15.3	19	24	EVGE-S-12-3/8"-NPT
S	630	12	1/2" NPT	M 20 x 1.5	50.0	22.0	20.0	22	24	EVGE-S-12-1/2"-NPT
S	630	14	1/2" NPT	M 22 x 1.5	48.0	23.5	20.0	22	27	EVGE-S-14-1/2"-NPT
S	400	16	1/2" NPT	M 24 x 1.5	54.0	24.0	20.0	22	30	EVGE-S-16-1/2"-NPT
S	400	20	3/4" NPT	M 30 x 2	58.0	28.0	20.0	27	36	EVGE-S-20-3/4"-NPT
S	400	25	1" NPT	M 36 x 2	68.0	33.0	25.0	36	46	EVGE-S-25-1"-NPT
S	400	30	1 1/4" NPT	M 42 x 2	73.0	33.0	25.5	46	50	EVGE-S-30-1 1/4"-NPT
S	315	38	1 1/2" NPT	M 52 x 2	81.0	38.0	26.0	50	60	EVGE-S-38-1 1/2"-NPT

Standpipe to metric parallel male - body only

BOOK INDEX

SECTION INDEX

These fittings are supplied without the nut and cutting ring pre-installed.

The male metric parallel parallel thread has an elastomeric Viton soft seal.

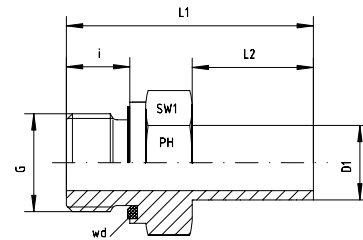

Series	Pressure PN	Tube O.D. D1	Thread G	Approx. Dimensions				Part code
				L1	L2	i	SW1	
L	315	6	M 10 x 1	32.5	19.0	8	14	EVGE-L-06-M 10x1-ov-wd
L	315	8	M 12 x 1.5	38.5	19.5	12	17	EVGE-L-08-M 12x1.5-ov-wd
L	315	10	M 14 x 1.5	39.5	20.5	12	19	EVGE-L-10-M 14x1.5-ov-wd
L	315	12	M 16 x 1.5	42.0	22.0	12	22	EVGE-L-12-M 16x1.5-ov-wd
L	315	15	M 18 x 1.5	43.5	23.0	12	24	EVGE-L-15-M 18x1.5-ov-wd
L	315	18	M 22 x 1.5	47.0	24.0	14	27	EVGE-L-18-M 22x1.5-ov-wd
L	160	22	M 26 x 1.5	50.5	24.5	16	32	EVGE-L-22-M 26x1.5-ov-wd
L	160	28	M 33 x 2	54.0	25.5	18	41	EVGE-L-28-M 33x2-ov-wd
L	160	35	M 42 x 2	62.5	30.5	20	50	EVGE-L-35-M 42x2-ov-wd
L	160	42	M 48 x 2	68.5	32.5	22	55	EVGE-L-42-M 48x2-ov-wd

Series	Pressure PN	Tube O.D. D1	Thread G	Approx. Dimensions				Part code
				L1	L2	i	SW1	
S	630	6	M 12 x 1.5	39.5	19.0	12	17	EVGE-S-06-M 12x1.5-ov-wd
S	630	8	M 14 x 1.5	40.5	19.5	12	19	EVGE-S-08-M 14x1.5-ov-wd
S	630	10	M 16 x 1.5	44.0	21.5	12	22	EVGE-S-10-M 16x1.5-ov-wd
S	630	12	M 18 x 1.5	46.0	22.5	12	24	EVGE-S-12-M 18x1.5-ov-wd
S	630	14	M 20 x 1.5	50.0	23.5	14	27	EVGE-S-14-M 20x1.5-ov-wd
S	400	16	M 22 x 1.5	51.0	24.0	14	27	EVGE-S-16-M 22x1.5-ov-wd
S	400	20	M 27 x 2	59.0	28.0	16	32	EVGE-S-20-M 27x2-ov-wd
S	400	25	M 33 x 2	65.5	31.0	18	41	EVGE-S-25-M 33x2-ov-wd
S	400	30	M 42 x 2	71.0	34.0	20	50	EVGE-S-30-M 42x2-ov-wd
S	315	38	M 48 x 2	83.5	40.0	22	55	EVGE-S-38-M 48x2-ov-wd

Adjustable standpipe to metric parallel male

BOOK INDEX

SECTION INDEX

to ISO 8434-1 / DIN 2353

L and S series

Cutting ring and nut is pre-assembled. It is necessary to tighten the nut 1/2 turn after an increase in torque is felt.

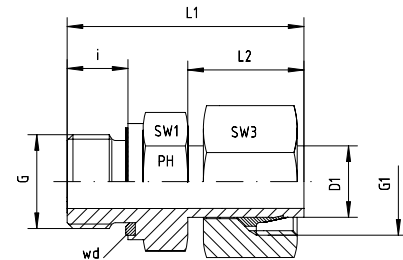

Series	Pressure PN	Tube O.D. D1	Thread		Approx. Dimensions					Part code
			G	G1	L1	L2	i	SW1	SW3	
L	315	6	M 10 x 1	M 12 x 1.5	32.5	19.0	8	14	14	EVGE-L-06-M 10x1-wd
L	315	8	M 12 x 1.5	M 14 x 1.5	38.5	19.5	12	17	17	EVGE-L-08-M 12x1.5-wd
L	315	10	M 14 x 1.5	M 16 x 1.5	39.5	20.5	12	19	19	EVGE-L-10-M 14x1.5-wd
L	315	12	M 16 x 1.5	M 18 x 1.5	42.0	22.0	12	22	22	EVGE-L-12-M 16x1.5-wd
L	315	15	M 18 x 1.5	M 22 x 1.5	43.5	23.0	12	24	27	EVGE-L-15-M 18x1.5-wd
L	315	18	M 22 x 1.5	M 26 x 1.5	47.0	24.0	14	27	32	EVGE-L-18-M 22x1.5-wd
L	160	22	M 26 x 1.5	M 30 x 2	50.5	24.5	16	32	36	EVGE-L-22-M 26x1.5-wd
L	160	28	M 33 x 2	M 36 x 2	54.0	25.5	18	41	41	EVGE-L-28-M 33x2-wd
L	160	35	M 42 x 2	M 45 x 2	62.5	30.5	20	50	50	EVGE-L-35-M 42x2-wd
L	160	42	M 48 x 2	M 52 x 2	68.5	32.5	22	55	60	EVGE-L-42-M 48x2-wd

Series	Pressure PN	Tube O.D. D1	Thread		Approx. Dimensions					Part code
			G	G1	L1	L2	i	SW1	SW3	
S	630	6	M 12 x 1.5	M 14 x 1.5	39.5	19.0	12	17	17	EVGE-S-06-M 12x1.5-wd
S	630	8	M 14 x 1.5	M 16 x 1.5	40.5	19.5	12	19	19	EVGE-S-08-M 14x1.5-wd
S	630	10	M 16 x 1.5	M 18 x 1.5	44.0	21.5	12	22	22	EVGE-S-10-M 16x1.5-wd
S	630	12	M 18 x 1.5	M 20 x 1.5	46.0	22.5	12	24	24	EVGE-S-12-M 18x1.5-wd
S	630	14	M 20 x 1.5	M 22 x 1.5	50.0	23.5	14	27	27	EVGE-S-14-M 20x1.5-wd
S	400	16	M 22 x 1.5	M 24 x 1.5	51.0	24.0	14	27	30	EVGE-S-16-M 22x1.5-wd
S	400	20	M 27 x 2	M 30 x 2	59.0	28.0	16	32	36	EVGE-S-20-M 27x2-wd
S	400	25	M 33 x 2	M 36 x 2	65.5	31.0	18	41	46	EVGE-S-25-M 33x2-wd
S	400	30	M 42 x 2	M 42 x 2	71.0	34.0	20	50	50	EVGE-S-30-M 42x2-wd
S	315	38	M 48 x 2	M 52 x 2	83.5	40.0	22	55	60	EVGE-S-38-M 48x2-wd



24° compression fittings to ISO 8434-1 / DIN 2354

BSP parallel female pressure gauge connector

BOOK INDEX

SECTION INDEX

to ISO 8434-1 / DIN 2353

L and S series

Supplied complete with
stainless internal sealing
ring

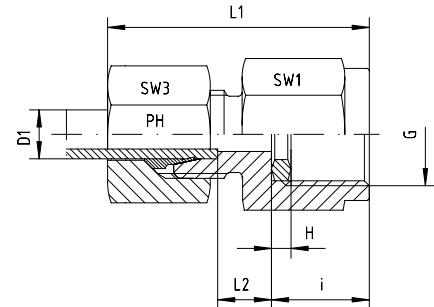

Series	Pressure PN	Tube O.D. D1	Thread G	Approx. Dimensions						Part code
				L1	L2	i	H	SW1	SW3	
L	315	6	G 1/4"	37.0	7.5	14.5	4.5	19	14	MV-L-06-G 1/4"
L	315	6	G 1/2"	46.0	9.0	20.0	5.0	27	14	MV-L-06-G 1/2"
L	315	8	G 1/4"	37.0	7.5	14.5	4.5	19	17	MV-L-08-G 1/4"
L	315	8	G 1/2"	46.0	9.0	20.0	5.0	27	17	MV-L-08-G 1/2"
L	315	10	G 1/4"	38.0	8.5	14.5	4.5	19	19	MV-L-10-G 1/4"
L	315	10	G 1/2"	47.0	9.5	20.0	5.0	27	19	MV-L-10-G 1/2"
L	315	12	G 1/4"	38.0	8.5	14.5	4.5	19	22	MV-L-12-G 1/4"
L	315	12	G 1/2"	48.0	10.0	20.0	5.0	27	22	MV-L-12-G 1/2"

Series	Pressure PN	Tube O.D. D1	Thread G	Approx. Dimensions						Part code
				L1	L2	i	H	SW1	SW3	
S	630	6	G 1/2"	46.0	11.0	20.0	5.0	27	17	MV-S-06-G 1/2"
S	630	8	G 1/4"	40.0	9.5	14.5	4.5	19	19	MV-S-08-G 1/4"
S	630	8	G 1/2"	46.0	11.0	20.0	5.0	27	19	MV-S-08-G 1/2"
S	630	10	G 1/4"	40.5	9.0	14.5	4.5	19	22	MV-S-10-G 1/4"
S	630	10	G 1/2"	47.0	10.5	20.0	5.0	27	22	MV-S-10-G 1/2"
S	630	12	G 1/4"	41.0	8.0	14.5	4.5	22	24	MV-S-12-G 1/4"
S	630	12	G 1/2"	47.0	10.5	20.0	5.0	27	24	MV-S-12-G 1/2"

Fittings can be supplied with nuts with silver-plated threads to help to prevent galling, or can be supplied body only - no nut or cutting ring.

If you require silver-plated nuts, use suffix -SC. If you require body only, use suffix -OMD.

Eg. MV-L-12-G 1/2"-SC, or MV-L-12-G 1/2"-OMD



24° compression fittings to ISO 8434-1 / DIN 2354

NPT female pressure gauge connector

BOOK INDEX

SECTION INDEX

to ISO 8434-1 / DIN 2353

L and S series

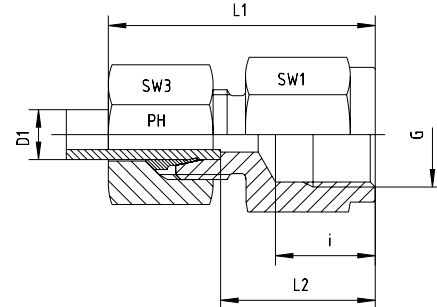

Series	Pressure PN	Tube O.D. D1	Thread G	Approx. Dimensions					Part code	
				L1	L2	i	SW1	SW3		
L	315	6	1/4" NPT	38	23.5	16.4	19	14		MV-L-06-NPT-1/4"
L	315	6	1/2" NPT	46	31.0	22.6	27	14		MV-L-06-NPT-1/2"
L	315	8	1/4" NPT	38	23.5	16.4	19	17		MV-L-08-NPT-1/4"
L	315	8	1/2" NPT	46	31.0	22.6	27	17		MV-L-08-NPT-1/2"
L	315	10	1/4" NPT	39	24.0	16.4	19	19		MV-L-10-NPT-1/4"
L	315	10	1/2" NPT	47	32.0	22.6	27	19		MV-L-10-NPT-1/2"
L	315	12	1/4" NPT			16.4	19	22		MV-L-12-NPT-1/4"
L	315	12	1/2" NPT	47	32.0	22.6	27	22		MV-L-12-NPT-1/2"

Series	Pressure PN	Tube O.D. D1	Thread G	Approx. Dimensions					Part code	
				L1	L2	i	SW1	SW3		
S	630	6	1/2" NPT	48	33.0	22.6	27	17		MV-S-06-NPT-1/2"
S	630	8	1/2" NPT	48	33.0	22.6	27	19		MV-S-08-NPT-1/2"
S	630	10	1/2" NPT	49	32.5	22.6	27	22		MV-S-10-NPT-1/2"
S	630	12	1/2" NPT	49	32.5	22.6	27	24		MV-S-12-NPT-1/2"

Fittings can be supplied with nuts with silver-plated threads to help to prevent galling, or can be supplied body only - no nut or cutting ring.

If you require silver-plated nuts, use suffix -SC. If you require body only, use suffix -OMD.

Eg. MV-L-12-NPT-1/2"-SC, or MV-L-12-NPT-1/2"-SC



24° compression fittings to ISO 8434-1 / DIN 2354

Adjustable BSP parallel female pressure gauge connector

BOOK INDEX

SECTION INDEX

to ISO 8434-1 / DIN 2353

L and S series

Supplied complete with stainless internal sealing ring.

Note - when assembling, a further 1/2 turn is required when the torque increase is felt.

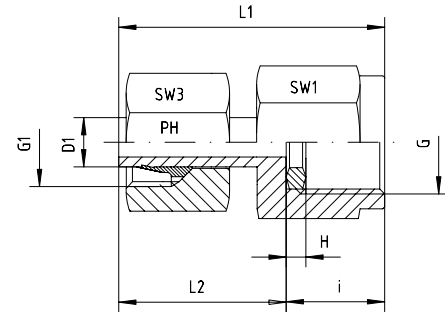

Series	Pressure PN	Tube O.D. D1	Thread		Approx. Dimensions						Part code
			G	G1	L1	L2	i	H	SW1	SW3	
L	315	6	G 1/4"	M 12 x 1.5	38.0		14.5	4.5	19	14	MV-ev-L-06-G 1/4"
L	315	6	G 1/2"	M 12 x 1.5	45.0		20.0	5.0	27	14	MV-ev-L-06-G 1/2"
L	315	8	G 1/4"	M 14 x 1.5	38.0		14.5	4.5	19	17	MV-ev-L-08-G 1/4"
L	315	8	G 1/2"	M 14 x 1.5	47.6		20.0	5.0	27	17	MV-ev-L-08-G 1/2"
L	315	10	G 1/4"	M 16 x 1.5	39.5		14.5	4.5	19	19	MV-ev-L-10-G 1/4"
L	315	10	G 1/2"	M 16 x 1.5	47.0		20.0	5.0	27	19	MV-ev-L-10-G 1/2"
L	315	12	G 1/4"	M 18 x 1.5	40.5		14.5	4.5	19	22	MV-ev-L-12-G 1/4"
L	315	12	G 1/2"	M 18 x 1.5	47.5		20.0	5.0	27	22	MV-ev-L-12-G 1/2"

Series	Pressure PN	Tube O.D. D1	Thread		Approx. Dimensions						Part code
			G	G1	L1	L2	i	H	SW1	SW3	
S	630	6	G 1/4"	M 14 x 1.5	38.0		14.5	4.5	19	17	MV-ev-S-06-G 1/4"
S	630	6	G 1/2"	M 14 x 1.5	45.0		20.0	5.0	27	17	MV-ev-S-06-G 1/2"
S	630	8	G 1/4"	M 16 x 1.5	38.0		14.5	4.5	19	19	MV-ev-S-08-G 1/4"
S	630	8	G 1/2"	M 16 x 1.5	47.6		20.0	5.0	27	19	MV-ev-S-08-G 1/2"
S	630	10	G 1/4"	M 18 x 1.5	39.5		14.5	4.5	19	22	MV-ev-S-10-G 1/4"
S	630	10	G 1/2"	M 18 x 1.5	47.0		20.0	5.0	27	22	MV-ev-S-10-G 1/2"
S	630	12	G 1/4"	M 20 x 1.5	40.5		14.5	4.5	19	24	MV-ev-S-12-G 1/4"
S	630	12	G 1/2"	M 20 x 1.5	47.5		20.0	5.0	27	24	MV-ev-S-12-G 1/2"

Fittings can be supplied with nuts with silver-plated threads to help to prevent galling, or can be supplied body only - no nut or cutting ring.

If you require silver-plated nuts, use suffix -SC. If you require body only, use suffix -OMD.

Eg. MV-ev-L-12-G 1/2"-SC, or MV-ev-L-12-G 1/2"-OMD

to ISO 8434-1 / DIN 2353

L and S series

Supplied complete with
stainless internal sealing ring.



Series	Pressure PN	Tube O.D. D1	Thread G	Approx. Dimensions						Part code
L	315	6	G 1/4"							MV-ev-L-06-G 1/4" -OMD
L	315	6	G 1/2"							MV-ev-L-06-G 1/2" -OMD
L	315	8	G 1/4"							MV-ev-L-08-G 1/4" -OMD
L	315	8	G 1/2"							MV-ev-L-08-G 1/2" -OMD
L	315	10	G 1/4"							MV-ev-L-10-G 1/4" -OMD
L	315	10	G 1/2"							MV-ev-L-10-G 1/2" -OMD
L	315	12	G 1/4"							MV-ev-L-12-G 1/4" -OMD
L	315	12	G 1/2"							MV-ev-L-12-G 1/2" -OMD

Series	Pressure PN	Tube O.D. D1	Thread G	Approx. Dimensions						Part code
S	630	6	G 1/4"							MV-ev-S-06-G 1/4" -OMD
S	630	6	G 1/2"							MV-ev-S-06-G 1/2" -OMD
S	630	8	G 1/4"							MV-ev-S-08-G 1/4" -OMD
S	630	8	G 1/2"							MV-ev-S-08-G 1/2" -OMD
S	630	10	G 1/4"							MV-ev-S-10-G 1/4" -OMD
S	630	10	G 1/2"							MV-ev-S-10-G 1/2" -OMD
S	630	12	G 1/4"							MV-ev-S-12-G 1/4" -OMD
S	630	12	G 1/2"							MV-ev-S-12-G 1/2" -OMD

Female stud coupling to BSP parallel

BOOK INDEX

SECTION INDEX

to ISO 8434-1 / DIN 2353

L and S series

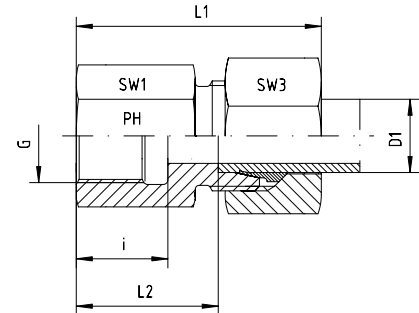
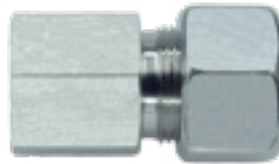

Series	Pressure PN	Tube O.D. D1	Thread G	Approx. Dimensions					Part code
				L1	L2	i	SW1	SW3	
L	315	6	G 1/8"	36.0	19.0	12.0	14	14	GAI-L-06-G 1/8"
L	315	6	G 1/4"	41.0	24.0	17.0	19	14	GAI-L-06-G 1/4"
L	315	6	G 3/8"	42.0	24.0	17.0	24	14	GAI-L-06-G 3/8"
L	315	6	G 1/2"	46.0	31.0	20.0	27	14	GAI-L-06-G 1/2"
L	315	8	G 1/8"	36.0	19.0	12.0	14	17	GAI-L-08-G 1/8"
L	315	8	G 1/4"	41.0	24.0	17.0	19	17	GAI-L-08-G 1/4"
L	315	8	G 3/8"	42.0	25.0	17.0	24	17	GAI-L-08-G 3/8"
L	315	8	G 1/2"	46.0	32.0	20.0	27	17	GAI-L-08-G 1/2"
L	315	10	G 1/8"	36.0	19.0	12.0	17	19	GAI-L-10-G 1/8"
L	315	10	G 1/4"	42.0	25.0	17.0	19	19	GAI-L-10-G 1/4"
L	315	10	G 3/8"	43.0	26.0	17.0	24	19	GAI-L-10-G 3/8"
L	315	10	G 1/2"	47.0	30.0	20.0	27	19	GAI-L-10-G 1/2"
L	315	12	G 1/4"	42.0	25.0	17.0	19	22	GAI-L-12-G 1/4"
L	315	12	G 3/8"	43.0	26.0	17.0	24	22	GAI-L-12-G 3/8"
L	315	12	G 1/2"	48.0	30.0	20.0	27	22	GAI-L-12-G 1/2"
L	315	15	G 3/8"	46.0	27.0	17.5	24	27	GAI-L-15-G 3/8"
L	315	15	G 1/2"	49.0	31.0	20.0	27	27	GAI-L-15-G 1/2"
L	160	15	G 3/4"	53.0	34.0	22.0	32	27	GAI-L-15-G 3/4"
L	315	18	G 3/8"	47.0	26.5	17.5	27	32	GAI-L-18-G 3/8"
L	315	18	G 1/2"	50.5	30.5	20.0	27	32	GAI-L-18-G 1/2"
L	160	18	G 3/4"	53.5	33.5	22.0	36	32	GAI-L-18-G 3/4"
L	160	22	G 1/2"	55.0	33.5	20.0	32	36	GAI-L-22-G 1/2"
L	160	22	G 3/4"	56.0	35.5	22.0	36	36	GAI-L-22-G 3/4"
L	160	28	G 3/4"	57.5	35.0	22.0	41	41	GAI-L-28-G 3/4"
L	160	28	G 1"	60.5	38.0	24.5	41	41	GAI-L-28-G 1"
L	160	35	G 1 1/4"	68.5	41.0	26.5	55	50	GAI-L-35-G 1 1/4"
L	160	42	G 1 1/2"	69.5	42.5	28.5	60	60	GAI-L-42-G 1 1/2"

Series	Pressure PN	Tube O.D. D1	Thread G	Approx. Dimensions					Part code
				L1	L2	i	SW1	SW3	
S	630	6	G 1/4"	42.0	26.0	17.0	19	17	GAI-S-06-G 1/4"
S	630	6	G 3/8"			17.0	24	17	GAI-S-06-G 3/8"
S	630	6	G 1/2"	48.0	31.0	20.0	27	17	GAI-S-06-G 1/2"
S	630	8	G 1/4"	43.0	26.0	17.0	19	19	GAI-S-08-G 1/4"
S	630	8	G 3/8"	44.0	27.0	17.0	24	19	GAI-S-08-G 3/8"
S	630	8	G 1/2"	48.0	31.0	20.0	27	19	GAI-S-08-G 1/2"
S	630	10	G 3/8"	45.0	26.5	17.0	24	22	GAI-S-10-G 3/8"
S	630	10	G 1/2"	49.5	30.5	20.0	27	22	GAI-S-10-G 1/2"
S	630	12	G 1/4"	46.0	27.5	17.0	22	24	GAI-S-12-G 1/4"
S	630	12	G 3/8"	45.0	26.5	17.0	24	24	GAI-S-12-G 3/8"
S	630	12	G 1/2"	50.0	30.5	20.0	27	24	GAI-S-12-G 1/2"
S	630	14	G 3/8"	50.0	30.0	17.0	24	27	GAI-S-14-G 3/8"
S	630	14	G 1/2"	52.0	32.0	20.0	27	27	GAI-S-14-G 1/2"
S	400	16	G 3/8"	48.0	26.5	17.5	27	30	GAI-S-16-G 3/8"
S	400	16	G 1/2"	53.0	31.5	20.0	27	30	GAI-S-16-G 1/2"
S	400	16	G 3/4"	55.0	34.5	22.0	36	30	GAI-S-16-G 3/4"
S	400	20	G 1/2"	57.0	32.5	20.0	32	36	GAI-S-20-G 1/2"
S	400	20	G 3/4"	60.0	34.5	22.0	32	36	GAI-S-20-G 3/4"
S	400	25	G 3/4"	60.0	35.0	22.0	41	46	GAI-S-25-G 3/4"
S	400	25	G 1"	66.5	37.5	24.5	41	46	GAI-S-25-G 1"
S	400	30	G 1 1/4"	72.5	42.0	26.5	55	50	GAI-S-30-G 1 1/4"
S	315	38	G 1 1/2"	79.5	43.5	28.5	60	60	GAI-S-38-G 1 1/2"

Female stud coupling to metric parallel

BOOK INDEX

SECTION INDEX

to ISO 8434-1 / DIN 2353

L and S series

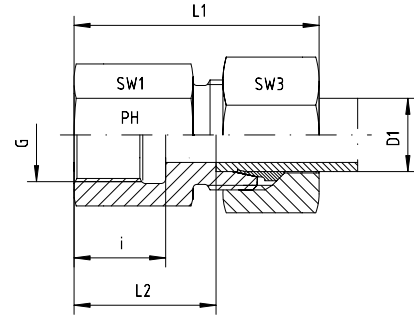
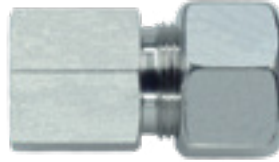

Series	Pressure PN	Tube O.D. D1	Thread G	Approx. Dimensions					Part code
				L1	L2	i	SW1	SW3	
L	315	6	M 10 x 1	34	19.5	12.5	14	14	GAI-L-06-M 10x1
L	315	8	M 12 x 1.5	39	24.0	17.0	17	17	GAI-L-08-M 12x1.5
L	315	10	M 14 x 1.5	40	25.0	17.0	19	19	GAI-L-10-M 14x1.5
L	315	12	M 16 x 1.5	41	26.0	17.0	22	22	GAI-L-12-M 16x1.5
L	315	15	M 18 x 1.5	43	28.0	17.0	24	27	GAI-L-15-M 18x1.5
L	315	18	M 22 x 1.5	46	29.5	19.0	30	32	GAI-L-18-M 22x1.5
L	160	22	M 26 x 1.5	51	34.5	21.0	32	36	GAI-L-22-M 26x1.5
L	160	28	M 33 x 2	54	37.5	24.0	41	41	GAI-L-28-M 33x2
L	160	35	M 42 x 2	62	40.5	26.0	50	50	GAI-L-35-M 42x2
L	160	42	M 48 x 2	65	42.0	28.0	55	60	GAI-L-42-M 48x2

Series	Pressure PN	Tube O.D. D1	Thread G	Approx. Dimensions					Part code
				L1	L2	i	SW1	SW3	
S	630	6	M 12 x 1.5	41	26.0	17.0	17	17	GAI-S-06-M 12x1.5
S	630	8	M 14 x 1.5	41	26.0	17.0	19	19	GAI-S-08-M 14x1.5
S	630	10	M 16 x 1.5	43	26.5	17.0	22	22	GAI-S-10-M 16x1.5
S	630	12	M 18 x 1.5	44	27.5	17.0	24	24	GAI-S-12-M 18x1.5
S	630	14	M 20 x 1.5	49	31.0	19.0	27	27	GAI-S-14-M 20x1.5
S	400	16	M 22 x 1.5	49	30.5	19.0	30	30	GAI-S-16-M 22x1.5
S	400	20	M 27 x 2	56	34.5	22.0	32	36	GAI-S-20-M 27x2
S	400	25	M 33 x 2	61	37.0	24.0	41	46	GAI-S-25-M 33x2
S	400	30	M 42 x 2	68	41.5	26.0	50	50	GAI-S-30-M 42x2
S	315	38	M 48 x 2	74	43.0	28.0	55	60	GAI-S-38-M 48x2

Fittings can be supplied with nuts with silver-plated threads to help to prevent galling, or can be supplied body only - no nut or cutting ring.

If you require silver-plated nuts, use suffix -SC. If you require body only, use suffix -OMD.

Eg. GAI-L-12-M 16x1.5-SC, or GAI-L-12-M 16x1.5-OMD



24° compression fittings to ISO 8434-1 / DIN 2354

Female stud coupling to NPT

BOOK INDEX

SECTION INDEX

to ISO 8434-1 / DIN 2353

L and S series

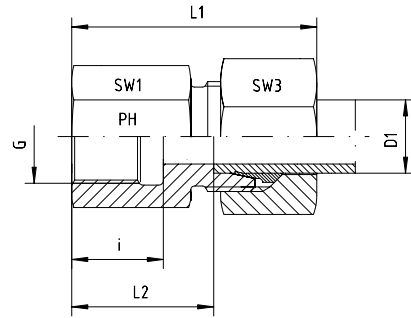

Series	Pressure PN	Tube O.D. D1	Thread G	Approx. Dimensions					Part code
				L1	L2	i	SW1	SW3	
L	315	6	1/8" NPT	34	19.0	11.6	14	14	GAI-L-06-1/8"-NPT
L	315	6	1/4" NPT	38	23.5	16.4	19	14	GAI-L-06-1/4"-NPT
L	315	6	3/8" NPT			17.4	24	14	GAI-L-06-3/8"-NPT
L	315	8	1/4" NPT	38	23.5	16.4	19	17	GAI-L-08-1/4"-NPT
L	315	8	3/8" NPT			17.4	24	17	GAI-L-08-3/8"-NPT
L	315	10	1/4" NPT	39	24.0	16.4	19	19	GAI-L-10-1/4"-NPT
L	315	10	3/8" NPT	43	26.0	17.4	24	19	GAI-L-10-3/8"-NPT
L	315	10	1/2" NPT			22.6	27	19	GAI-L-10-1/2"-NPT
L	315	12	1/4" NPT			16.4	19	22	GAI-L-12-1/4"-NPT
L	315	12	3/8" NPT	42	27.0	17.4	24	22	GAI-L-12-3/8"-NPT
L	315	12	1/2" NPT	47	32.0	22.6	27	22	GAI-L-12-1/2"-NPT
L	315	15	3/8" NPT			17.4	24	27	GAI-L-15-3/8"-NPT
L	315	15	1/2" NPT	48	33.0	22.6	27	27	GAI-L-15-1/2"-NPT
L	315	18	1/2" NPT	49	32.5	22.6	27	27	GAI-L-18-1/2"-NPT
L	160	22	3/4" NPT	52	35.5	23.1	36	36	GAI-L-22-3/4"-NPT
L	160	28	1" NPT	57	40.5	27.8	41	41	GAI-L-28-1"-NPT
L	160	35	1 1/4" NPT	62	40.5	28.3	55	50	GAI-L-35-1 1/4"-NPT
L	160	42	1 1/2" NPT	65	42.0	28.3	60	60	GAI-L-42-1 1/2"-NPT

Series	Pressure PN	Tube O.D. D1	Thread G	Approx. Dimensions					Part code
				L1	L2	i	SW1	SW3	
S	630	6	1/4" NPT	41	26.0	16.4	19	17	GAI-S-06-1/4"-NPT
S	630	8	1/4" NPT	41	26.0	16.4	19	19	GAI-S-08-1/4"-NPT
S	630	10	3/8" NPT	44	27.0	17.4	24	22	GAI-S-10-3/8"-NPT
S	630	12	3/8" NPT	44	27.5	17.4	24	24	GAI-S-12-3/8"-NPT
S	630	12	1/2" NPT	50	33.5	22.6	27	24	GAI-S-12-1/2"-NPT
S	630	14	1/2" NPT	53	35.0	22.6	27	27	GAI-S-14-1/2"-NPT
S	400	16	3/8" NPT	48	27.5	17.4	27	30	GAI-S-16-3/8"-NPT
S	400	16	1/2" NPT	50	34.5	22.6	27	30	GAI-S-16-1/2"-NPT
S	400	20	3/4" NPT	57	35.5	23.1	32	36	GAI-S-20-3/4"-NPT
S	400	25	1" NPT	65	41.0	27.8	41	46	GAI-S-25-1"-NPT
S	400	30	1 1/4" NPT	70	43.5	28.3	55	50	GAI-S-30-1 1/4"-NPT
S	315	38	1 1/2" NPT	74	43.0	28.3	60	60	GAI-S-38-1 1/2"-NPT

Fittings can be supplied with nuts with silver-plated threads to help to prevent galling, or can be supplied body only - no nut or cutting ring.

If you require silver-plated nuts, use suffix -SC. If you require body only, use suffix -OMD.

Eg. GAI-L-12-1/2"-NPT-SC, or GAI-L-12-1/2"-NPT-OMD

Banjo elbow to BSP parallel

BOOK INDEX

SECTION INDEX

to ISO 8434-1 / DIN 2353

LL, L and S series

Supplied with stainless external sealing ring as per DIN 3852, bonded seal upon request. Please lubricate the bolt with anti-galling paste before assembly.

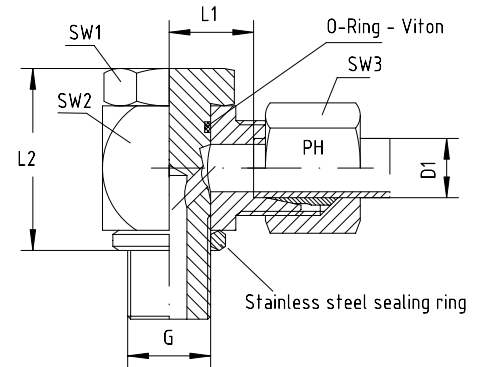

Series	Pressure PN	Tube O.D. D1	Thread G	Approx. Dimensions					Part code
				L1	L2	SW1	SW2	SW3	
LL	100	4	G 1/8"	11.0	24	17	18	10	WHV-LL-04-G 1/8"
LL	100	6	G 1/8"	11.5	24	17	18	12	WHV-LL-06-G 1/8"
LL	100	8	G 1/8"	11.5	24	17	18	14	WHV-LL-08-G 1/8"

Series	Pressure PN	Tube O.D. D1	Thread G	Approx. Dimensions					Part code
				L1	L2	SW1	SW2	SW3	
L	500	6	G 1/8"	12.0	24	17	18	14	WHV-L-06-G 1/8"
L	400	8	G 1/4"	14.5	30	19	22	17	WHV-L-08-G 1/4"
L	350	10	G 1/4"	15.5	30	19	22	19	WHV-L-10-G 1/4"
L	350	10	G 3/8"	17.5	35	24	27	19	WHV-L-10-G 3/8"
L	350	12	G 1/4"	15.5	30	19	22	22	WHV-L-12-G 1/4"
L	350	12	G 3/8"	18.0	36	24	27	22	WHV-L-12-G 3/8"
L	315	12	G 1/2"	21.5	45	30	32	22	WHV-L-12-G 1/2"
L	315	15	G 1/2"	21.5	45	30	32	27	WHV-L-15-G 1/2"
L	315	18	G 1/2"	21.0	45	30	32	32	WHV-L-18-G 1/2"
L	200	22	G 3/4"	27.5	53	36	40	36	WHV-L-22-G 3/4"
L	200	28	G 1"	32.0	66	46	50	41	WHV-L-28-G 1"
L	200	35	G 1 1/4"	36.0	76	55	60	50	WHV-L-35-G 1 1/4"
L	200	42	G 1 1/2"	40.5	87	60	70	60	WHV-L-42-G 1 1/2"

Series	Pressure PN	Tube O.D. D1	Thread G	Approx. Dimensions					Part code
				L1	L2	SW1	SW2	SW3	
S	500	6	G 1/4"	16.5	30	19	22	17	WHV-S-06-G 1/4"
S	450	8	G 1/4"	16.5	30	19	22	19	WHV-S-08-G 1/4"
S	400	10	G 1/4"	16.5	30	19	22	22	WHV-S-10-G 1/4"
S	400	10	G 3/8"	18.5	36	24	27	22	WHV-S-10-G 3/8"
S	400	12	G 3/8"	18.5	36	24	27	24	WHV-S-12-G 3/8"
S	400	14	G 1/2"	22.5	45	30	32	27	WHV-S-14-G 1/2"
S	400	16	G 1/2"	22.0	45	30	32	30	WHV-S-16-G 1/2"
S	400	20	G 3/4"	26.5	53	36	40	36	WHV-S-20-G 3/4"
S	250	25	G 1"	31.5	66	46	50	46	WHV-S-25-G 1"
S	250	30	G 1 1/4"	37.0	76	55	60	50	WHV-S-30-G 1 1/4"
S	250	38	G 1 1/2"	41.5	87	60	70	60	WHV-S-38-G 1 1/2"

Banjo elbow to BSP parallel

BOOK INDEX

SECTION INDEX

to ISO 8434-1 / DIN 2353

LL, L and S series

Designed for tight access to ISO 1179.

Supplied with bonded seal as standard.

Please lubricate the bolt with anti-galling paste before assembly.

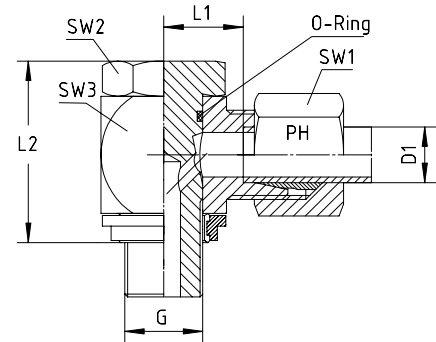

Series	Pressure PN	Tube O.D. D1	Thread G	Approx. Dimensions					Part code
				L1	L2	SW1	SW2	SW3	
LL	100	4	G 1/8"	11.0	24	17	18	10	WHV-LL-04-G 1/8"-WDS
LL	100	6	G 1/8"	11.5	24	17	18	12	WHV-LL-06-G 1/8"-WDS
LL	100	8	G 1/8"	11.5	24	17	18	14	WHV-LL-08-G 1/8"-WDS

Series	Pressure PN	Tube O.D. D1	Thread G	Approx. Dimensions					Part code
				L1	L2	SW1	SW2	SW3	
L	500	6	G 1/8"	12.0	24	17	18	14	WHV-L-06-G 1/8"-WDS
L	400	8	G 1/4"	14.5	30	19	22	17	WHV-L-08-G 1/4"-WDS
L	350	10	G 1/4"	15.5	30	19	22	19	WHV-L-10-G 1/4"-WDS
L	350	10	G 3/8"	17.5	35	24	27	19	WHV-L-10-G 3/8"-WDS
L	350	12	G 1/4"	15.5	30	19	22	22	WHV-L-12-G 1/4"-WDS
L	350	12	G 3/8"	18.0	36	24	27	22	WHV-L-12-G 3/8"-WDS
L	315	12	G 1/2"	21.5	45	30	32	22	WHV-L-12-G 1/2"-WDS
L	315	15	G 1/2"	21.5	45	30	32	27	WHV-L-15-G 1/2"-WDS
L	315	18	G 1/2"	21.0	45	30	32	32	WHV-L-18-G 1/2"-WDS
L	200	22	G 3/4"	27.5	53	36	40	36	WHV-L-22-G 3/4"-WDS
L	200	28	G 1"	32.0	66	46	50	41	WHV-L-28-G 1"-WDS
L	200	35	G 1 1/4"	36.0	76	55	60	50	WHV-L-35-G 1 1/4"-WDS
L	200	42	G 1 1/2"	40.5	87	60	70	60	WHV-L-42-G 1 1/2"-WDS

Series	Pressure PN	Tube O.D. D1	Thread G	Approx. Dimensions					Part code
				L1	L2	SW1	SW2	SW3	
S	500	6	G 1/4"	16.5	30	19	22	17	WHV-S-06-G 1/4"-WDS
S	450	8	G 1/4"	16.5	30	19	22	19	WHV-S-08-G 1/4"-WDS
S	400	10	G 1/4"	16.5	30	19	22	22	WHV-S-10-G 1/4"-WDS
S	400	10	G 3/8"	18.5	36	24	27	22	WHV-S-10-G 3/8"-WDS
S	400	12	G 3/8"	18.5	36	24	27	24	WHV-S-12-G 3/8"-WDS
S	400	14	G 1/2"	22.5	45	30	32	27	WHV-S-14-G 1/2"-WDS
S	400	16	G 1/2"	22.0	45	30	32	30	WHV-S-16-G 1/2"-WDS
S	400	20	G 3/4"	26.5	53	36	40	36	WHV-S-20-G 3/4"-WDS
S	250	25	G 1"	31.5	66	46	50	46	WHV-S-25-G 1"-WDS
S	250	30	G 1 1/4"	37.0	76	55	60	50	WHV-S-30-G 1 1/4"-WDS
S	250	38	G 1 1/2"	41.5	87	60	70	60	WHV-S-38-G 1 1/2"-WDS

Banjo elbow to metric parallel

BOOK INDEX

SECTION INDEX

to ISO 8434-1 / DIN 2353

LL, L and S series

Supplied with stainless external sealing ring as per DIN 3852, bonded seal upon request. Please lubricate the bolt with anti-galling paste before assembly.

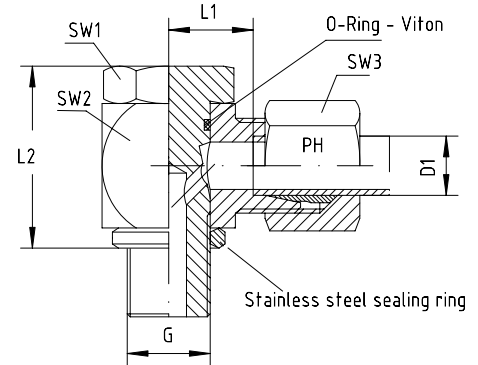

Series	Pressure PN	Tube O.D. D1	Thread G	Approx. Dimensions					Part code
				L1	L2	SW1	SW2	SW3	
LL	100	4	M 8 x 1	11.0	24.0	17	18	10	WHV-LL-04-M 8x1
LL	100	6	M 10 x 1	11.5	24.0	17	18	12	WHV-LL-06-M 10x1
LL	100	8	M 10 x 1	11.5	24.0	17	18	14	WHV-LL-08-M 10x1

Series	Pressure PN	Tube O.D. D1	Thread G	Approx. Dimensions					Part code
				L1	L2	SW1	SW2	SW3	
L	500	6	M 10 x 1	12.0	24.0	17	18	14	WHV-L-06-M 10x1
L	400	8	M 12 x 1.5	14.5	30.0	19	22	17	WHV-L-08-M 12x1.5
L	350	10	M 14 x 1.5	15.5	30.0	19	22	19	WHV-L-10-M 14x1.5
L	315	12	M 16 x 1.5	18.0	36.0	24	27	22	WHV-L-12-M 16x1.5
L	315	15	M 18 x 1.5	20.5	39.5	27	30	27	WHV-L-15-M 18x1.5
L	315	18	M 22 x 1.5	21.0	45.0	30	32	32	WHV-L-18-M 22x1.5
L	200	22	M 26 x 1.5	27.5	53.0	36	40	36	WHV-L-22-M 26x1.5
L	200	28	M 33 x 2	32.0	66.0	46	50	41	WHV-L-28-M 33x2
L	200	35	M 42 x 2	36.0	76.0	55	60	50	WHV-L-35-M 42x2
L	200	42	M 48 x 2	40.5	87.0	60	70	60	WHV-L-42-M 48x2

Series	Pressure PN	Tube O.D. D1	Thread G	Approx. Dimensions					Part code
				L1	L2	SW1	SW2	SW3	
S	500	6	M 12 x 1.5	16.5	30.0	19	22	17	WHV-S-06-M 12x1.5
S	450	8	M 14 x 1.5	16.5	30.0	19	22	19	WHV-S-08-M 14x1.5
S	400	10	M 16 x 1.5	18.5	36.0	24	27	22	WHV-S-10-M 16x1.5
S	400	12	M 18 x 1.5	20.0	39.5	27	30	24	WHV-S-12-M 18x1.5
S	400	14	M 20 x 1.5	22.5	43.5	30	32	27	WHV-S-14-M 20x1.5
S	400	16	M 22 x 1.5	22.0	45.0	30	32	30	WHV-S-16-M 22x1.5
S	400	20	M 27 x 2	26.5	53.0	36	40	36	WHV-S-20-M 27x2
S	250	25	M 33 x 2	31.5	66.0	46	50	46	WHV-S-25-M 33x2
S	250	30	M 42 x 2	37.0	76.0	55	60	50	WHV-S-30-M 42x2
S	250	38	M 48 x 2	41.5	87.0	60	70	60	WHV-S-38-M 48x2

Fittings can be supplied with nuts with silver-plated threads to help to prevent galling, or can be supplied body only - no nut or cutting ring.

If you require silver-plated nuts, use suffix -SC. If you require body only, use suffix -OMD.

Eg. WHV-L-12-M 16x1.5-SC, or WHV-L-12-M 16x1.5-OMD

Banjo elbow to metric parallel

BOOK INDEX

SECTION INDEX

to ISO 8434-1 / DIN 2353

LL, L and S series

Designed for tight access to ISO 9974.

Supplied with Viton bonded seal as standard.

Please lubricate the bolt with anti-galling paste before assembly.

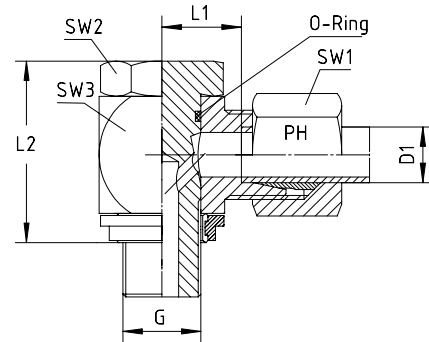

Series	Pressure PN	Tube O.D. D1	Thread G	Approx. Dimensions					Part code
				L1	L2	SW1	SW2	SW3	
LL	100	6	M 10 x 1	11.5	24.0	17	18	12	WHV-LL-06-M 10x1-WDS
LL	100	8	M 10 x 1	11.5	24.0	17	18	14	WHV-LL-08-M 10x1-WDS

Series	Pressure PN	Tube O.D. D1	Thread G	Approx. Dimensions					Part code
				L1	L2	SW1	SW2	SW3	
L	500	6	M 10 x 1	12.0	24.0	17	18	14	WHV-L-06-M 10x1-WDS
L	400	8	M 12 x 1.5	14.5	30.0	19	22	17	WHV-L-08-M 12x1.5-WDS
L	350	10	M 14 x 1.5	15.5	30.0	19	22	19	WHV-L-10-M 14x1.5-WDS
L	315	12	M 16 x 1.5	18.0	36.0	24	27	22	WHV-L-12-M 16x1.5-WDS
L	315	15	M 18 x 1.5	20.5	39.5	27	30	27	WHV-L-15-M 18x1.5-WDS
L	315	18	M 22 x 1.5	21.0	45.0	30	32	32	WHV-L-18-M 22x1.5-WDS
L	200	22	M 26 x 1.5	27.5	53.0	36	40	36	WHV-L-22-M 26x1.5-WDS
L	200	28	M 33 x 2	32.0	66.0	46	50	41	WHV-L-28-M 33x2-WDS
L	200	35	M 42 x 2	36.0	76.0	55	60	50	WHV-L-35-M 42x2-WDS
L	200	42	M 48 x 2	40.5	87.0	60	70	60	WHV-L-42-M 48x2-WDS

Series	Pressure PN	Tube O.D. D1	Thread G	Approx. Dimensions					Part code
				L1	L2	SW1	SW2	SW3	
S	500	6	M 12 x 1.5	16.5	30.0	19	22	17	WHV-S-06-M 12x1.5-WDS
S	450	8	M 14 x 1.5	16.5	30.0	19	22	19	WHV-S-08-M 14x1.5-WDS
S	400	10	M 16 x 1.5	18.5	36.0	24	27	22	WHV-S-10-M 16x1.5-WDS
S	400	12	M 18 x 1.5	20.0	39.5	27	30	24	WHV-S-12-M 18x1.5-WDS
S	400	16	M 22 x 1.5	22.0	45.0	30	32	30	WHV-S-16-M 22x1.5-WDS
S	400	20	M 27 x 2	26.5	53.0	36	40	36	WHV-S-20-M 27x2-WDS
S	250	25	M 33 x 2	31.5	66.0	46	50	46	WHV-S-25-M 33x2-WDS
S	250	30	M 42 x 2	37.0	76.0	55	60	50	WHV-S-30-M 42x2-WDS
S	250	38	M 48 x 2	41.5	87.0	60	70	60	WHV-S-38-M 48x2-WDS

Fittings can be supplied with nuts with silver-plated threads to help to prevent galling, or can be supplied body only - no nut or cutting ring.

If you require silver-plated nuts, use suffix -SC. If you require body only, use suffix -OMD.

Eg. WHV-L-12-M 16x1.5-WDS-SC, or WHV-L-12-M 16x1.5-WDS-OMD

Banjo tee to BSP parallel

BOOK INDEX

SECTION INDEX

to ISO 8434-1 / DIN 2353

LL, L and S series

Supplied with stainless external sealing ring as per DIN 3852, bonded seal upon request. Please lubricate the bolt with anti-galling paste before assembly.

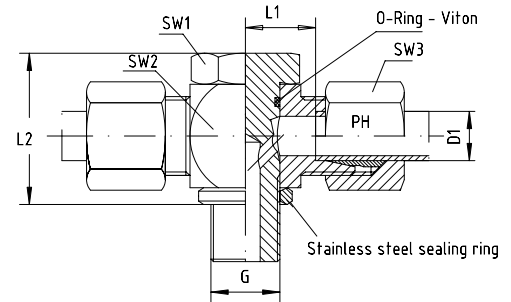

Series	Pressure PN	Tube O.D. D1	Thread G	Approx. Dimensions					Part code
				L1	L2	SW1	SW2	SW3	
LL	100	4	G 1/8"	11.0	24	17	18	10	THV-LL-04-R 1/8"
LL	100	6	G 1/8"	11.5	24	17	18	12	THV-LL-06-R 1/8"
LL	100	8	G 1/8"	11.5	24	17	18	14	THV-LL-08-R 1/8"

Series	Pressure PN	Tube O.D. D1	Thread G	Approx. Dimensions					Part code
				L1	L2	SW1	SW2	SW3	
L	500	6	G 1/8"	12.0	24	17	18	14	THV-L-06-R 1/8"
L	400	8	G 1/4"	14.5	30	19	22	17	THV-L-08-R 1/4"
L	350	10	G 1/4"	15.5	30	19	22	19	THV-L-10-R 1/4"
L	350	12	G 1/4"	15.5	30	19	22	22	THV-L-12-R 1/4"
L	350	12	G 3/8"	18.0	36	24	27	22	THV-L-12-R 3/8"
L	315	15	G 1/2"	21.5	45	30	32	27	THV-L-15-R 1/2"
L	315	18	G 1/2"	21.0	45	30	32	32	THV-L-18-R 1/2"
L	200	22	G 3/4"	27.5	53	36	40	36	THV-L-22-R 3/4"
L	200	28	G 1"	32.0	66	46	50	41	THV-L-28-R 1"
L	200	35	G 1 1/4"	36.0	76	55	60	50	THV-L-35-R 1 1/4"
L	200	42	G 1 1/2"	40.5	87	60	70	60	THV-L-42-R 1 1/2"

Series	Pressure PN	Tube O.D. D1	Thread G	Approx. Dimensions					Part code
				L1	L2	SW1	SW2	SW3	
S	500	6	G 1/4"	16.5	30	19	22	17	THV-S-06-R 1/4"
S	450	8	G 1/4"	16.5	30	19	22	19	THV-S-08-R 1/4"
S	400	10	G 1/4"	16.5	30	19	22	22	THV-S-10-R 1/4"
S	400	10	G 3/8"	18.5	36	24	27	22	THV-S-10-R 3/8"
S	400	12	G 3/8"	18.5	36	24	27	24	THV-S-12-R 3/8"
S	400	14	G 1/2"	22.5	45	30	32	27	THV-S-14-R 1/2"
S	400	16	G 1/2"	22.0	45	30	32	30	THV-S-16-R 1/2"
S	400	20	G 3/4"	26.5	53	36	40	36	THV-S-20-R 3/4"
S	250	25	G 1"	31.5	66	46	50	46	THV-S-25-R 1"
S	250	30	G 1 1/4"	37.0	76	55	60	50	THV-S-30-R 1 1/4"
S	250	38	G 1 1/2"	41.5	87	60	70	60	THV-S-38-R 1 1/2"

Fittings can be supplied with nuts with silver-plated threads to help to prevent galling, or can be supplied body only - no nut or cutting ring.

If you require silver-plated nuts, use suffix -SC. If you require body only, use suffix -OMD.

Eg. THV-L-12-R 3/8"-SC, or THV-L-12-R 3/8"-OMD

Banjo tee to BSP parallel

BOOK INDEX

SECTION INDEX

to ISO 8434-1 / DIN 2353

LL, L and S series

Designed for tight access to ISO 1179.

Supplied with bonded seal as standard.

Please lubricate the bolt with anti-galling paste before assembly.

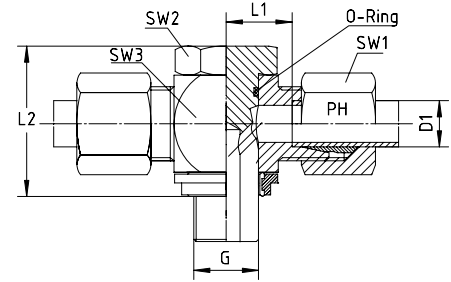

Series	Pressure PN	Tube O.D. D1	Thread G	Approx. Dimensions					Part code
				L1	L2	SW1	SW2	SW3	
LL	100	4	G 1/8"	11.0	24	17	18	10	THV-LL-04-R 1/8"-WDS
LL	100	6	G 1/8"	11.5	24	17	18	12	THV-LL-06-R 1/8"-WDS
LL	100	8	G 1/8"	11.5	24	17	18	14	THV-LL-08-R 1/8"-WDS

Series	Pressure PN	Tube O.D. D1	Thread G	Approx. Dimensions					Part code
				L1	L2	SW1	SW2	SW3	
L	500	6	G 1/8"	12.0	24	17	18	14	THV-L-06-R 1/8"-WDS
L	400	8	G 1/4"	14.5	30	19	22	17	THV-L-08-R 1/4"-WDS
L	350	10	G 1/4"	15.5	30	19	22	19	THV-L-10-R 1/4"-WDS
L	350	12	G 1/4"	15.5	30	19	22	22	THV-L-12-R 1/4"-WDS
L	350	12	G 3/8"	18.0	36	24	27	22	THV-L-12-R 3/8"-WDS
L	315	15	G 1/2"	21.5	45	30	32	27	THV-L-15-R 1/2"-WDS
L	315	18	G 1/2"	21.0	45	30	32	32	THV-L-18-R 1/2"-WDS
L	200	22	G 3/4"	27.5	53	36	40	36	THV-L-22-R 3/4"-WDS
L	200	28	G 1"	32.0	66	46	50	41	THV-L-28-R 1"-WDS
L	200	35	G 1 1/4"	36.0	76	55	60	50	THV-L-35-R 1 1/4"-WDS
L	200	42	G 1 1/2"	40.5	87	60	70	60	THV-L-42-R 1 1/2"-WDS

Series	Pressure PN	Tube O.D. D1	Thread G	Approx. Dimensions					Part code
				L1	L2	SW1	SW2	SW3	
S	500	6	G 1/4"	16.5	30	19	22	17	THV-S-06-R 1/4"-WDS
S	450	8	G 1/4"	16.5	30	19	22	19	THV-S-08-R 1/4"-WDS
S	400	10	G 1/4"	16.5	30	19	22	22	THV-S-10-R 1/4"-WDS
S	400	10	G 3/8"	18.5	36	24	27	22	THV-S-10-R 3/8"-WDS
S	400	12	G 3/8"	18.5	36	24	27	24	THV-S-12-R 3/8"-WDS
S	400	14	G 1/2"	22.5	45	30	32	27	THV-S-14-R 1/2"-WDS
S	400	16	G 1/2"	22.0	45	30	32	30	THV-S-16-R 1/2"-WDS
S	400	20	G 3/4"	26.5	53	36	40	36	THV-S-20-R 3/4"-WDS
S	250	25	G 1"	31.5	66	46	50	46	THV-S-25-R 1"-WDS
S	250	30	G 1 1/4"	37.0	76	55	60	50	THV-S-30-R 1 1/4"-WDS
S	250	38	G 1 1/2"	41.5	87	60	70	60	THV-S-38-R 1 1/2"-WDS

Fittings can be supplied with nuts with silver-plated threads to help to prevent galling, or can be supplied body only - no nut or cutting ring.

If you require silver-plated nuts, use suffix -SC. If you require body only, use suffix -OMD.

Eg. THV-L-12-R 3/8"-WDS-SC, or THV-L-12-R 3/8"-WDS-OMD

Banjo tee to metric parallel

BOOK INDEX

SECTION INDEX

to ISO 8434-1 / DIN 2353

LL, L and S series

Supplied with stainless external sealing ring as per DIN 3852, bonded seal upon request. Please lubricate the bolt with anti-galling paste before assembly.

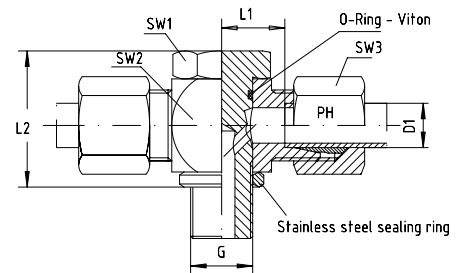

Series	Pressure PN	Tube O.D. D1	Thread G	Approx. Dimensions					Part code
				L1	L2	SW1	SW2	SW3	
LL	100	4	M 8 x 1	11.0	24.0	17	18	10	THV-LL-04-M 8x1
LL	100	6	M 10 x 1	11.5	24.0	17	18	12	THV-LL-06-M 10x1
LL	100	8	M 10 x 1	11.5	24.0	17	18	14	THV-LL-08-M 10x1

Series	Pressure PN	Tube O.D. D1	Thread G	Approx. Dimensions					Part code
				L1	L2	SW1	SW2	SW3	
L	500	6	M 10 x 1	12.0	24.0	17	18	14	THV-L-06-M 10x1
L	400	8	M 12 x 1.5	14.5	30.0	19	22	17	THV-L-08-M 12x1.5
L	350	10	M 14 x 1.5	15.5	30.0	19	22	19	THV-L-10-M 14x1.5
L	350	12	M 16 x 1.5	18.0	36.0	24	27	22	THV-L-12-M 16x1.5
L	315	15	M 18 x 1.5	20.5	39.5	27	30	27	THV-L-15-M 18x1.5
L	315	18	M 22 x 1.5	21.0	45.0	30	32	32	THV-L-18-M 22x1.5
L	200	22	M 26 x 1.5	27.5	53.0	36	40	36	THV-L-22-M 26x1.5
L	200	28	M 33 x 2	32.0	66.0	46	50	41	THV-L-28-M 33x2
L	200	35	M 42 x 2	36.0	76.0	55	60	50	THV-L-35-M 42x2
L	200	42	M 48 x 2	40.5	87.0	60	70	60	THV-L-42-M 48x2

Series	Pressure PN	Tube O.D. D1	Thread G	Approx. Dimensions					Part code
				L1	L2	SW1	SW2	SW3	
S	500	6	M 12 x 1.5	16.5	30.0	19	22	17	THV-S-06-M 12x1.5
S	450	8	M 14 x 1.5	16.5	30.0	19	22	19	THV-S-08-M 14x1.5
S	400	10	M 16 x 1.5	18.5	36.0	24	27	22	THV-S-10-M 16x1.5
S	400	12	M 18 x 1.5	20.0	39.5	27	30	24	THV-S-12-M 18x1.5
S	400	14	M 20 x 1.5	22.5	43.5	30	32	27	THV-S-14-M 20x1.5
S	400	16	M 22 x 1.5	22.0	45.0	30	32	30	THV-S-16-M 22x1.5
S	400	20	M 27 x 2	26.5	53.0	36	40	36	THV-S-20-M 27x2
S	250	25	M 33 x 2	31.5	66.0	46	50	46	THV-S-25-M 33x2
S	250	30	M 42 x 2	37.0	76.0	55	60	50	THV-S-30-M 42x2
S	250	38	M 48 x 2	41.5	87.0	60	70	60	THV-S-38-M 48x2

Fittings can be supplied with nuts with silver-plated threads to help to prevent galling, or can be supplied body only - no nut or cutting ring.

If you require silver-plated nuts, use suffix -SC. If you require body only, use suffix -OMD.

Eg. THV-L-12-M 16x1.5-SC, or THV-L-12-M 16x1.5-OMD

Banjo tee to metric parallel

BOOK INDEX

SECTION INDEX

to ISO 8434-1 / DIN 2353

LL, L and S series

Designed for tight access to ISO 9974.

Supplied with Viton bonded seal as standard.

Please lubricate the bolt with anti-galling paste before assembly.

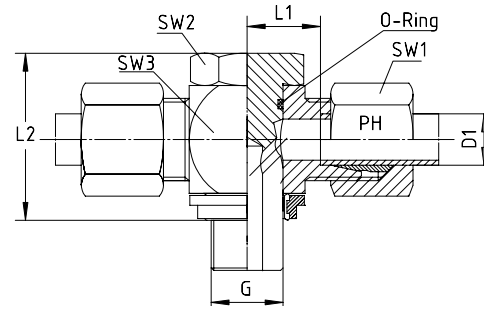

Series	Pressure PN	Tube O.D. D1	Thread G	Approx. Dimensions					Part code
				L1	L2	SW1	SW2	SW3	
LL	100	6	M 10 x 1	11.5	24.0	17	18	12	THV-LL-06-M 10x1-WDS
LL	100	8	M 10 x 1	11.5	24.0	17	18	14	THV-LL-08-M 10x1-WDS

Series	Pressure PN	Tube O.D. D1	Thread G	Approx. Dimensions					Part code
				L1	L2	SW1	SW2	SW3	
L	500	6	M 10 x 1	12.0	24.0	17	18	14	THV-L-06-M 10x1-WDS
L	400	8	M 12 x 1.5	14.5	30.0	19	22	17	THV-L-08-M 12x1.5-WDS
L	350	10	M 14 x 1.5	15.5	30.0	19	22	19	THV-L-10-M 14x1.5-WDS
L	350	12	M 16 x 1.5	18.0	36.0	24	27	22	THV-L-12-M 16x1.5-WDS
L	315	15	M 18 x 1.5	20.5	39.5	27	30	27	THV-L-15-M 18x1.5-WDS
L	315	18	M 22 x 1.5	21.0	45.0	30	32	32	THV-L-18-M 22x1.5-WDS
L	200	22	M 26 x 1.5	27.5	53.0	36	40	36	THV-L-22-M 26x1.5-WDS
L	200	28	M 33 x 2	32.0	66.0	46	50	41	THV-L-28-M 33x2-WDS
L	200	35	M 42 x 2	36.0	76.0	55	60	50	THV-L-35-M 42x2-WDS
L	200	42	M 48 x 2	40.5	87.0	60	70	60	THV-L-42-M 48x2-WDS

Series	Pressure PN	Tube O.D. D1	Thread G	Approx. Dimensions					Part code
				L1	L2	SW1	SW2	SW3	
S	500	6	M 12 x 1.5	16.5	30.0	19	22	17	THV-S-06-M 12x1.5-WDS
S	450	8	M 14 x 1.5	16.5	30.0	19	22	19	THV-S-08-M 14x1.5-WDS
S	400	10	M 16 x 1.5	18.5	36.0	24	27	22	THV-S-10-M 16x1.5-WDS
S	400	12	M 18 x 1.5	20.0	39.5	27	30	24	THV-S-12-M 18x1.5-WDS
S	400	16	M 22 x 1.5	22.0	45.0	30	32	30	THV-S-16-M 22x1.5-WDS
S	400	20	M 27 x 2	26.5	53.0	36	40	36	THV-S-20-M 27x2-WDS
S	250	25	M 33 x 2	31.5	66.0	46	50	46	THV-S-25-M 33x2-WDS
S	250	30	M 42 x 2	37.0	76.0	55	60	50	THV-S-30-M 42x2-WDS
S	250	38	M 48 x 2	41.5	87.0	60	70	60	THV-S-38-M 48x2-WDS

Fittings can be supplied with nuts with silver-plated threads to help to prevent galling, or can be supplied body only - no nut or cutting ring.

If you require silver-plated nuts, use suffix -SC. If you require body only, use suffix -OMD.

Eg. THV-L-12-M 16x1.5-WDS-SC, or THV-L-12-M 16x1.5-WDS-OMD



24° compression fittings to ISO 8434-1 / DIN 2354

Adjustable male stud elbow to BSP parallel

BOOK INDEX

SECTION INDEX

to ISO 8434-1 / DIN 2353

L and S series

Viton O-ring seal with
retaining ring to ISO 1179

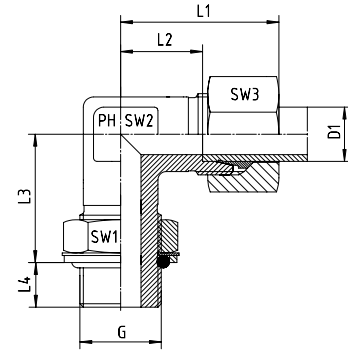

Series	Pressure PN	Tube O.D. D1	Thread G = BSP	Approx. Dimensions								Part code
				L1	L2	L3	L4	SW1	SW2	SW3	D1	
L	315	6	G 1/8"	29	14	19	7	14	14	14	6	WEEV-LR-06-G 1/8"
L	315	8	G 1/4"	31	16	23	9	19	14	17	8	WEEV-LR-08-G 1/4"
L	315	10	G 1/4"	32	17	25	9	19	19	19	10	WEEV-LR-10-G 1/4"
L	250	12	G 3/8"	34	19	28	9	22	19	22	12	WEEV-LR-12-G 3/8"
L	250	15	G 1/2"	36	21	30	13	27	19	27	15	WEEV-LR-15-G 1/2"
L	250	18	G 1/2"	40	24	36	13	27	27	32	18	WEEV-LR-18-G 1/2"
L	160	22	G 3/4"	44	28	36	13	36	27	36	22	WEEV-LR-22-G 3/4"
L	160	28	G 1"	47	31	44	15	41	36	41	28	WEEV-LR-28-G 1"
L	160	35	G 1 1/4"	59	38	50	15	50	50	50	35	WEEV-LR-35-G 1 1/4"
L	160	42	G 1 1/2"	61	38	52	15	55	50	60	42	WEEV-LR-42-G 1 1/2"

Series	Pressure PN	Tube O.D. D1	Thread G = BSP	Approx. Dimensions								Part code
				L1	L2	L3	L4	SW1	SW2	SW3	D1	
S	315	6	G 1/4"	30	15	23	9	19	14	17	6	WEEV-SR-06-G 1/4"
S	315	8	G 1/4"	32	17	27	9	19	19	19	8	WEEV-SR-08-G 1/4"
S	250	10	G 3/8"	34	18	29	9	22	19	22	10	WEEV-SR-10-G 3/8"
S	250	12	G 3/8"	38	22	29	9	22	22	24	12	WEEV-SR-12-G 3/8"
S	250	16	G 1/2"	43	25	36	13	27	27	30	16	WEEV-SR-16-G 1/2"
S	250	20	G 3/4"	49	28	39	12	36	30	36	20	WEEV-SR-20-G 3/4"
S	250	25	G 1"	54	30	44	14	41	36	46	25	WEEV-SR-25-G 1"
S	160	30	G 1 1/4"	52	36	49	15	50	50	50	30	WEEV-SR-30-G 1 1/4"
S	160	38	G 1 1/2"	65	34	55	15	55	50	60	38	WEEV-SR-38-G 1 1/2"

Fittings can be supplied with nuts with silver-plated threads to help to prevent galling, or can be supplied body only - no nut or cutting ring.

If you require silver-plated nuts, use suffix -SC. If you require body only, use suffix -OMD.

Eg. WEEV-LR-12-G 3/8"-SC, or WEEV-LR-12-G 3/8"-OMD

Adjustable standpipe elbow

BOOK INDEX

SECTION INDEX

to ISO 8434-1 / DIN 2353

L and S series

The swivel female must be finally assembled with a 1/2 turn after torque increases.

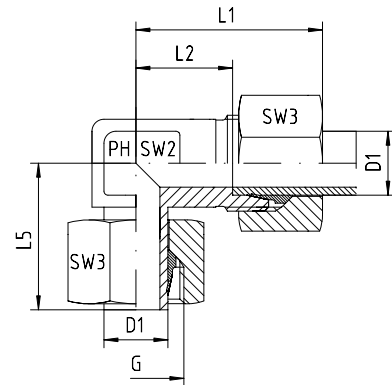

Series	Pressure PN	Tube O.D. D1	Thread G	Approx. Dimensions					Part code
				L1	L2	L5	SW2	SW3	
L	315	6	M 12 x 1.5	27	12.0	26.0	12	14	EVW-L-06
L	315	8	M 14 x 1.5	29	14.0	27.5	12	17	EVW-L-08
L	315	10	M 16 x 1.5	30	15.0	29.0	14	19	EVW-L-10
L	315	12	M 18 x 1.5	32	17.0	29.5	17	22	EVW-L-12
L	315	15	M 22 x 1.5	36	21.0	32.5	19	27	EVW-L-15
L	315	18	M 26 x 1.5	40	23.5	35.5	24	32	EVW-L-18
L	160	22	M 30 x 2	44	27.5	38.5	27	36	EVW-L-22
L	160	28	M 36 x 2	47	30.5	43.5	36	41	EVW-L-28
L	160	35	M 45 x 2	56	34.5	54.0	41	50	EVW-L-35
L	160	42	M 52 x 2	63	40.0	56.0	50	60	EVW-L-42

Series	Pressure PN	Tube O.D. D1	Thread G	Approx. Dimensions					Part code
				L1	L2	L5	SW2	SW3	
S	630	6	M 14 x 1.5	31	16.0	27.0	12	17	EVW-S-06
S	630	8	M 16 x 1.5	32	17.0	27.5	14	19	EVW-S-08
S	630	10	M 18 x 1.5	34	17.5	30.0	17	22	EVW-S-10
S	630	12	M 20 x 1.5	38	21.5	31.0	17	24	EVW-S-12
S	630	14	M 22 x 1.5	40	22.0	35.0	19	27	EVW-S-14
S	400	16	M 24 x 1.5	43	24.5	36.5	24	30	EVW-S-16
S	400	20	M 30 x 2	48	26.5	44.5	27	36	EVW-S-20
S	400	25	M 36 x 2	54	30.0	50.0	36	46	EVW-S-25
S	400	30	M 42 x 2	62	35.5	55.0	41	50	EVW-S-30
S	250	38	M 52 x 2	72	41.0	63.0	50	60	EVW-S-38

Fittings can be supplied with nuts with silver-plated threads to help to prevent galling, or can be supplied body only - no nut or cutting ring.

If you require silver-plated nuts, use suffix -SC. If you require body only, use suffix -OMD.

Eg. EVW-L-12-SC, or EVW-L-12-OMD

Adjustable standpipe elbow with BSP parallel male stud

BOOK INDEX

SECTION INDEX

to ISO 8434-1 / DIN 2353

L and S series

Form B sealing shoulder

The swivel female must be finally assembled with a 1/2 turn after torque increases.

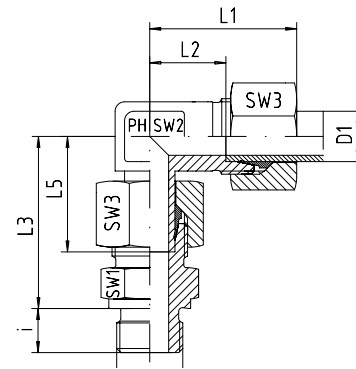

Series	Pressure PN	Tube O.D D1	Thread G	Approx. Dimensions								Part code
				L1	L2	L3	L5	i	SW1	SW2	SW3	
L	315	6	G 1/8"	27	12.0	34.5	26.0	8	14	12	14	EVW-L-06-G 1/8"
L	315	8	G 1/4"	29	14.0	37.5	27.5	12	17	12	17	EVW-L-08-G 1/4"
L	315	10	G 1/4"	30	15.0	40.0	29.0	12	19	14	19	EVW-L-10-G 1/4"
L	315	12	G 1/4"	32	17.0	42.0	29.5	12	19	17	22	EVW-L-12-G 1/4"
L	315	12	G 3/8"	32	17.0	42.0	29.5	12	22	17	22	EVW-L-12-G 3/8"
L	315	12	G 1/2"	32	17.0	43.0	29.5	14	27	17	22	EVW-L-12-G 1/2"
L	315	15	G 1/2"	36	21.0	46.5	32.5	14	27	19	27	EVW-L-15-G 1/2"
L	315	18	G 1/2"	40	23.5	50.0	35.5	14	27	24	32	EVW-L-18-G 1/2"
L	160	22	G 3/4"	44	27.5	55.0	38.5	16	32	27	36	EVW-L-22-G 3/4"
L	160	28	G 1"	47	30.5	61.0	43.5	18	41	36	41	EVW-L-28-G 1"
L	160	35	G 1 1/4"	56	34.5	71.5	54.0	20	50	41	50	EVW-L-35-G 1 1/4"
L	160	42	G 1 1/2"	63	40.0	75.0	56.0	22	55	50	60	EVW-L-42-G 1 1/2"

Series	Pressure PN	Tube O.D D1	Thread G	Approx. Dimensions								Part code
				L1	L2	L3	L5	i	SW1	SW2	SW3	
S	630	6	G 1/4"	31	16.0	40.0	27.0	12	19	12	17	EVW-S-06-G 1/4"
S	630	8	G 1/4"	32	17.0	42.5	27.5	12	19	14	19	EVW-S-08-G 1/4"
S	630	10	G 3/8"	34	17.5	45.0	30.0	12	22	17	22	EVW-S-10-G 3/8"
S	630	12	G 3/8"	38	21.5	48.0	31.0	12	22	17	24	EVW-S-12-G 3/8"
S	630	12	G 1/2"	38	21.5	50.0	31.0	14	27	17	24	EVW-S-12-G 1/2"
S	630	14	G 1/2"	40	22.0	54.0	35.0	14	27	19	27	EVW-S-14-G 1/2"
S	400	16	G 1/2"	43	24.5	55.0	36.5	14	27	24	30	EVW-S-16-G 1/2"
S	400	20	G 3/4"	48	26.5	65.0	44.5	16	32	27	36	EVW-S-20-G 3/4"
S	400	25	G 1"	54	30.0	73.0	50.0	18	41	36	46	EVW-S-25-G 1"
S	400	30	G 1 1/4"	62	35.5	78.5	55.0	20	50	41	50	EVW-S-30-G 1 1/4"
S	250	38	G 1 1/2"	72	41.0	89.0	63.0	22	55	50	60	EVW-S-38-G 1 1/2"

Fittings can be supplied with nuts with silver-plated threads to help to prevent galling, or can be supplied body only - no nut or cutting ring.

If you require silver-plated nuts, use suffix -SC. If you require body only, use suffix -OMD.

Eg. EVW-L-12-G 1/2"-SC, or EVW-L-12-G 1/2"-OMD



24° compression fittings to ISO 8434-1 / DIN 2354

Adjustable standpipe elbow with metric parallel male stud

BOOK INDEX

SECTION INDEX

to ISO 8434-1 / DIN 2353

L and S series

Form B sealing shoulder

The swivel female must be finally assembled with a 1/2 turn after torque increases.

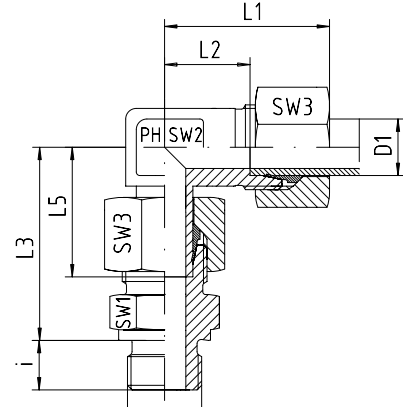

Series	Pressure PN	Tube O.D. D1	Thread G	Approx. Dimensions								Part code
				L1	L2	L3	L5	i	SW1	SW2	SW3	
L	315	6	M 10 x 1	27	12.0	34.5	26.0	8	14	12	14	EVW-L-06-M 10x1
L	315	8	M 12 x 1.5	29	14.0	37.5	27.5	12	17	12	17	EVW-L-08-M 12x1.5
L	315	10	M 14 x 1.5	30	15.0	40.0	29.0	12	19	14	19	EVW-L-10-M 14x1.5
L	315	12	M 16 x 1.5	32	17.0	42.0	29.5	12	22	17	22	EVW-L-12-M 16x1.5
L	315	15	M 18 x 1.5	36	21.0	46.0	32.5	12	24	19	27	EVW-L-15-M 18x1.5
L	315	18	M 22 x 1.5	40	23.5	50.0	35.5	14	27	24	32	EVW-L-18-M 22x1.5
L	160	22	M 26 x 1.5	44	27.5	55.0	38.5	16	32	27	36	EVW-L-22-M 26x1.5
L	160	28	M 33 x 2	47	30.5	61.0	43.5	18	41	36	41	EVW-L-28-M 33x2
L	160	35	M 42 x 2	56	34.5	71.5	54.0	20	50	41	50	EVW-L-35-M 42x2
L	160	42	M 48 x 2	63	40.0	75.0	56.0	22	55	50	60	EVW-L-42-M 48x2

Series	Pressure PN	Tube O.D. D1	Thread G	Approx. Dimensions								Part code
				L1	L2	L3	L5	i	SW1	SW2	SW3	
S	630	6	M 12 x 1.5	31	16.0	40.0	27.0	12	17	12	17	EVW-S-06-M 12x1.5
S	630	8	M 14 x 1.5	32	17.0	42.5	27.5	12	19	14	19	EVW-S-08-M 14x1.5
S	630	10	M 16 x 1.5	34	17.5	45.0	30.0	12	22	17	22	EVW-S-10-M 16x1.5
S	630	12	M 18 x 1.5	38	21.5	48.0	31.0	12	24	17	24	EVW-S-12-M 18x1.5
S	630	14	M 20 x 1.5	40	22.0	54.0	35.0	14	27	19	27	EVW-S-14-M 20x1.5
S	400	16	M 22 x 1.5	43	24.5	55.0	36.5	14	27	24	30	EVW-S-16-M 22x1.5
S	400	20	M 27 x 2	48	26.5	65.0	44.5	16	32	27	36	EVW-S-20-M 27x2
S	400	25	M 33 x 2	54	30.0	73.0	50.0	18	41	36	46	EVW-S-25-M 33x2
S	400	30	M 42 x 2	62	35.5	78.5	55.0	20	50	41	50	EVW-S-30-M 42x2
S	250	38	M 48 x 2	72	41.0	89.0	63.0	22	55	50	60	EVW-S-38-M 48x2

Fittings can be supplied with nuts with silver-plated threads to help to prevent galling, or can be supplied body only - no nut or cutting ring.

If you require silver-plated nuts, use suffix -SC. If you require body only, use suffix -OMD.

Eg. EVW-L-12-M 16x1.5-SC, or EVW-L-12-M 16x1.5-OMD



24° compression fittings to ISO 8434-1 / DIN 2354

Adjustable standpipe branch tee

BOOK INDEX

SECTION INDEX

to ISO 8434-1 / DIN 2353

L and S series

The swivel female must be finally assembled with a 1/2 turn after torque increases.

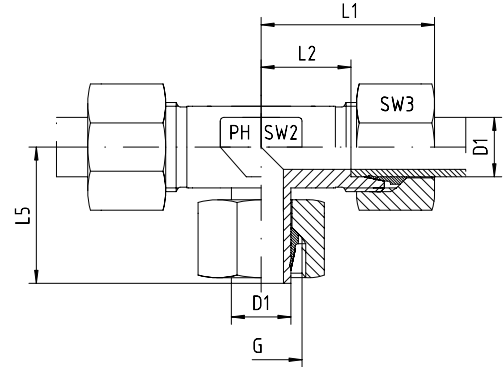
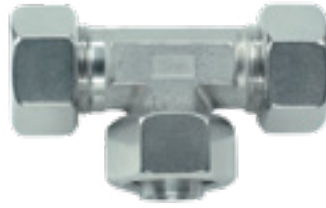

Series	Pressure PN	Tube O.D. D1	Thread G	Approx. Dimensions					Part code
				L1	L2	L5	SW2	SW3	
L	315	6	M 12 x 1.5	27	12.0	26.0	12	14	EVT-L-06
L	315	8	M 14 x 1.5	29	14.0	27.5	12	17	EVT-L-08
L	315	10	M 16 x 1.5	30	15.0	29.0	14	19	EVT-L-10
L	315	12	M 18 x 1.5	32	17.0	29.5	17	22	EVT-L-12
L	315	15	M 22 x 1.5	36	21.0	32.5	19	27	EVT-L-15
L	315	18	M 26 x 1.5	40	23.5	35.5	24	32	EVT-L-18
L	160	22	M 30 x 2	44	27.5	38.5	27	36	EVT-L-22
L	160	28	M 36 x 2	47	30.5	41.5	36	41	EVT-L-28
L	160	35	M 45 x 2	56	34.5	54.0	41	50	EVT-L-35
L	160	42	M 52 x 2	63	40.0	56.0	50	60	EVT-L-42

Series	Pressure PN	Tube O.D. D1	Thread G	Approx. Dimensions					Part code
				L1	L2	L5	SW2	SW3	
S	630	6	M 14 x 1.5	31	16.0	27.0	12	17	EVT-S-06
S	630	8	M 16 x 1.5	32	17.0	27.5	14	19	EVT-S-08
S	630	10	M 18 x 1.5	34	17.5	30.0	17	22	EVT-S-10
S	630	12	M 20 x 1.5	38	21.5	31.0	17	24	EVT-S-12
S	630	14	M 22 x 1.5	40	22.0	35.0	19	27	EVT-S-14
S	400	16	M 24 x 1.5	43	24.5	36.5	24	30	EVT-S-16
S	400	20	M 30 x 2	48	26.5	44.5	27	36	EVT-S-20
S	400	25	M 36 x 2	54	30.0	50.0	36	46	EVT-S-25
S	400	30	M 42 x 2	62	35.5	55.0	41	50	EVT-S-30
S	250	38	M 52 x 2	72	41.0	63.0	50	60	EVT-S-38

Fittings can be supplied with nuts with silver-plated threads to help to prevent galling, or can be supplied body only - no nut or cutting ring.

If you require silver-plated nuts, use suffix -SC. If you require body only, use suffix -OMD.

Eg. EVT-L-12-SC, or EVT-L-12-OMD



24° compression fittings to ISO 8434-1 / DIN 2354

Adjustable standpipe branch tee with BSP parallel male stud

BOOK INDEX

SECTION INDEX

to ISO 8434-1 / DIN 2353

L and S series

Form B sealing shoulder

The swivel female must be finally assembled with a 1/2 turn after torque increases.

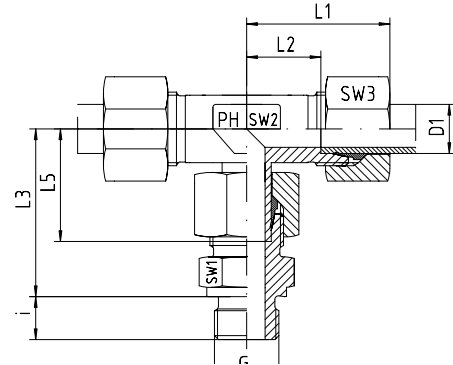

Series	Pressure PN	Tube O.D. D1	Thread G	Approx. Dimensions								Part code
				L1	L2	L3	L5	i	SW1	SW2	SW3	
L	315	6	G 1/8"	27	12.0	34.5	26.0	8	14	12	14	EVT-L-06-G 1/8"
L	315	8	G 1/4"	29	14.0	37.5	27.5	12	19	12	17	EVT-L-08-G 1/4"
L	315	10	G 1/4"	30	15.0	40.0	29.0	12	19	14	19	EVT-L-10-G 1/4"
L	315	12	G 3/8"	32	17.0	42.0	29.5	12	22	17	22	EVT-L-12-G 3/8"
L	315	15	G 1/2"	36	21.0	46.5	32.5	14	27	19	27	EVT-L-15-G 1/2"
L	315	18	G 1/2"	40	23.5	50.0	35.5	14	27	24	32	EVT-L-18-G 1/2"
L	160	22	G 3/4"	44	27.5	65.0	38.5	16	32	27	36	EVT-L-22-G 3/4"
L	160	28	G 1"	47	30.5	59.0	41.5	18	41	36	41	EVT-L-28-G 1"
L	160	35	G 1 1/4"	56	34.5	71.5	54.0	20	50	41	50	EVT-L-35-G 1 1/4"
L	160	42	G 1 1/2"	63	40.0	75.0	56.0	22	55	50	60	EVT-L-42-G 1 1/2"

Series	Pressure PN	Tube O.D. D1	Thread G	Approx. Dimensions								Part code
				L1	L2	L3	L5	i	SW1	SW2	SW3	
S	630	6	G 1/4"	31	16.0	40.0	27.0	12	19	12	17	EVT-S-06-G 1/4"
S	630	8	G 1/4"	32	17.0	42.5	27.5	12	19	14	19	EVT-S-08-G 1/4"
S	630	10	G 3/8"	34	17.5	45.0	30.0	12	22	17	22	EVT-S-10-G 3/8"
S	630	12	G 3/8"	38	21.5	48.0	31.0	12	22	17	24	EVT-S-12-G 3/8"
S	630	14	G 1/2"	40	22.0	54.0	35.0	14	27	19	27	EVT-S-14-G 1/2"
S	400	16	G 1/2"	43	24.5	55.0	36.5	14	27	24	30	EVT-S-16-G 1/2"
S	400	20	G 3/4"	48	26.5	65.0	44.5	16	32	27	36	EVT-S-20-G 3/4"
S	400	25	G 1"	54	30.0	73.0	50.0	18	41	36	46	EVT-S-25-G 1"
S	400	30	G 1 1/4"	62	35.5	78.5	55.0	20	50	41	50	EVT-S-30-G 1 1/4"
S	250	38	G 1 1/2"	72	41.0	89.0	63.0	22	55	50	60	EVT-S-38-G 1 1/2"

Fittings can be supplied with nuts with silver-plated threads to help to prevent galling, or can be supplied body only - no nut or cutting ring.

If you require silver-plated nuts, use suffix -SC. If you require body only, use suffix -OMD.

Eg. EVT-L-12-G 3/8"-SC, or EVT-L-12-G 3/8"-OMD

Adjustable standpipe branch tee with metric parallel male stud

BOOK INDEX

SECTION INDEX

to ISO 8434-1 / DIN 2353

L and S series

Form B sealing shoulder

The swivel female must be finally assembled with a 1/2 turn after torque increases.

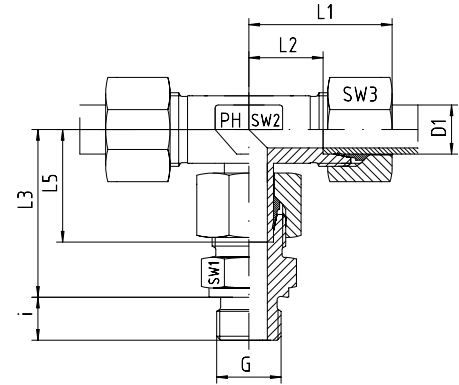

Series	Pressure PN	Tube O.D. D1	Thread G	Approx. Dimensions								Part code
				L1	L2	L3	L5	i	SW1	SW2	SW3	
L	315	6	M 10 x 1	27	12.0	34.5	26.0	8	14	12	14	EVT-L-06-M 10x1
L	315	8	M 12 x 1.5	29	14.0	37.5	27.5	12	17	12	17	EVT-L-08-M 12x1.5
L	315	10	M 14 x 1.5	30	15.0	40.0	29.0	12	19	14	19	EVT-L-10-M 14x1.5
L	315	12	M 16 x 1.5	32	17.0	42.0	29.5	12	22	17	22	EVT-L-12-M 16x1.5
L	315	15	M 18 x 1.5	36	21.0	46.0	32.5	12	24	19	27	EVT-L-15-M 18x1.5
L	315	18	M 22 x 1.5	40	23.5	50.0	35.5	14	27	24	32	EVT-L-18-M 22x1.5
L	160	22	M 26 x 1.5	44	27.5	55.0	38.5	16	32	27	36	EVT-L-22-M 26x1.5
L	160	28	M 33 x 2	47	30.5	59.0	41.5	18	41	36	41	EVT-L-28-M 33x2
L	160	35	M 42 x 2	56	34.5	71.5	54.0	20	50	41	50	EVT-L-35-M 42x2
L	160	42	M 48 x 2	63	40.0	75.0	56.0	22	55	50	60	EVT-L-42-M 48x2

Series	Pressure PN	Tube O.D. D1	Thread G	Approx. Dimensions								Part code
				L1	L2	L3	L5	i	SW1	SW2	SW3	
S	630	6	M 12 x 1.5	31	16.0	40.0	27.0	12	17	12	17	EVT-S-06-M 12x1.5
S	630	8	M 14 x 1.5	32	17.0	42.5	27.5	12	19	14	19	EVT-S-08-M 14x1.5
S	630	10	M 16 x 1.5	34	17.5	45.0	30.0	12	22	17	22	EVT-S-10-M 16x1.5
S	630	12	M 18 x 1.5	38	21.5	48.0	31.0	12	24	17	24	EVT-S-12-M 18x1.5
S	630	14	M 20 x 1.5	40	22.0	54.0	35.0	14	27	19	27	EVT-S-14-M 20x1.5
S	400	16	M 22 x 1.5	43	24.5	55.0	36.5	14	27	24	30	EVT-S-16-M 22x1.5
S	400	20	M 27 x 2	48	26.5	65.0	44.5	16	32	27	36	EVT-S-20-M 27x2
S	400	25	M 33 x 2	54	30.0	73.0	50.0	18	41	36	46	EVT-S-25-M 33x2
S	400	30	M 42 x 2	62	35.5	78.5	55.0	20	50	41	50	EVT-S-30-M 42x2
S	250	38	M 48 x 2	72	41.0	89.0	63.0	22	55	50	60	EVT-S-38-M 48x2

Fittings can be supplied with nuts with silver-plated threads to help to prevent galling, or can be supplied body only - no nut or cutting ring.

If you require silver-plated nuts, use suffix -SC. If you require body only, use suffix -OMD.

Eg. EVT-L-12-M 16x1.5-SC, EVT-L-12-M 16x1.5-OMD

Adjustable standpipe run tee

BOOK INDEX

SECTION INDEX

to ISO 8434-1 / DIN 2353

L and S series

The swivel female must be finally assembled with a 1/2 turn after torque increases.

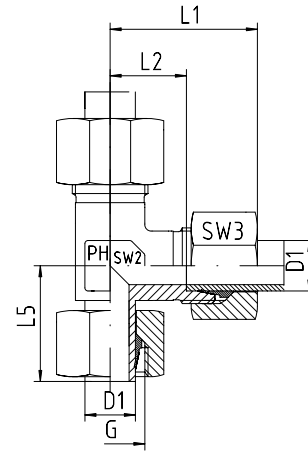

Series	Pressure PN	Tube O.D. D1	Thread G	Approx. Dimensions					Part code
				L1	L2	L5	SW2	SW3	
L	315	6	M 12 x 1.5	27	12.0	26.0	12	14	EVL-L-06
L	315	8	M 14 x 1.5	29	14.0	27.5	12	17	EVL-L-08
L	315	10	M 16 x 1.5	30	15.0	29.0	14	19	EVL-L-10
L	315	12	M 18 x 1.5	32	17.0	29.5	17	22	EVL-L-12
L	315	15	M 22 x 1.5	36	21.0	32.5	19	27	EVL-L-15
L	315	18	M 26 x 1.5	40	23.5	35.5	24	32	EVL-L-18
L	160	22	M 30 x 2	44	27.5	38.5	27	36	EVL-L-22
L	160	28	M 36 x 2	47	30.5	43.5	36	41	EVL-L-28
L	160	35	M 45 x 2	56	34.5	54.0	41	50	EVL-L-35
L	160	42	M 52 x 2	63	40.0	56.0	50	60	EVL-L-42

Series	Pressure PN	Tube O.D. D1	Thread G	Approx. Dimensions					Part code
				L1	L2	L5	SW2	SW3	
S	630	6	M 14 x 1.5	31	16.0	27.0	12	17	EVL-S-06
S	630	8	M 16 x 1.5	32	17.0	27.5	14	19	EVL-S-08
S	630	10	M 18 x 1.5	34	17.5	30.0	17	22	EVL-S-10
S	630	12	M 20 x 1.5	38	21.5	31.0	17	24	EVL-S-12
S	630	14	M 22 x 1.5	40	22.0	35.0	19	27	EVL-S-14
S	400	16	M 24 x 1.5	43	24.5	36.5	24	30	EVL-S-16
S	400	20	M 30 x 2	48	26.5	44.5	27	36	EVL-S-20
S	400	25	M 36 x 2	54	30.0	50.0	36	46	EVL-S-25
S	400	30	M 42 x 2	62	35.5	55.0	41	50	EVL-S-30
S	250	38	M 52 x 2	72	41.0	63.0	50	60	EVL-S-38

Fittings can be supplied with nuts with silver-plated threads to help to prevent galling, or can be supplied body only - no nut or cutting ring.

If you require silver-plated nuts, use suffix -SC. If you require body only, use suffix -OMD.

Eg. EVL-L-12-SC, or EVL-L-12-OMD

Adjustable standpipe run tee with BSP parallel male stud

BOOK INDEX

SECTION INDEX

to ISO 8434-1 / DIN 2353

L and S series

Form B sealing shoulder

The swivel female must be finally assembled with a 1/2 turn after torque increases.

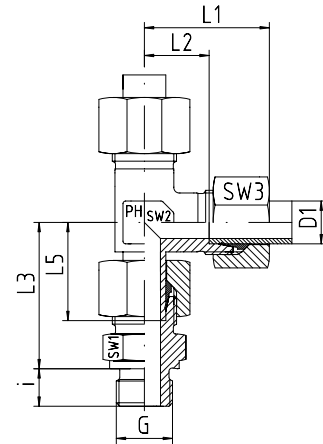

Series	Pressure PN	Tube O.D. D1	Thread G	Approx. Dimensions								Part code
				L1	L2	L3	L5	i	SW1	SW2	SW3	
L	315	6	G 1/8"	27	12.0	34.5	26.0	8	14	12	14	EVL-L-06-G 1/8"
L	315	8	G 1/4"	29	14.0	37.5	27.5	12	19	12	17	EVL-L-08-G 1/4"
L	315	10	G 1/4"	30	15.0	40.0	29.0	12	19	14	19	EVL-L-10-G 1/4"
L	315	12	G 3/8"	32	17.0	42.0	29.5	12	22	17	22	EVL-L-12-G 3/8"
L	315	15	G 1/2"	36	21.0	46.5	32.5	14	27	19	27	EVL-L-15-G 1/2"
L	315	18	G 1/2"	40	23.5	50.0	35.5	14	27	24	32	EVL-L-18-G 1/2"
L	160	22	G 3/4"	44	27.5	55.0	38.5	16	32	27	36	EVL-L-22-G 3/4"
L	160	28	G 1"	47	30.5	61.0	43.5	18	41	36	41	EVL-L-28-G 1"
L	160	35	G 1 1/4"	56	34.5	71.5	54.0	20	50	41	50	EVL-L-35-G 1 1/4"
L	160	42	G 1 1/2"	63	40.0	75.0	56.0	22	55	50	60	EVL-L-42-G 1 1/2"

Series	Pressure PN	Tube O.D. D1	Thread G	Approx. Dimensions								Part code
				L1	L2	L3	L5	i	SW1	SW2	SW3	
S	630	6	G 1/4"	31	16.0	40.0	27.0	12	19	12	17	EVL-S-06-G 1/4"
S	630	8	G 1/4"	32	17.0	42.5	27.5	12	19	14	19	EVL-S-08-G 1/4"
S	630	10	G 3/8"	34	17.5	45.0	30.0	12	22	17	22	EVL-S-10-G 3/8"
S	630	12	G 3/8"	38	21.5	48.0	31.0	12	22	17	24	EVL-S-12-G 3/8"
S	630	14	G 1/2"	40	22.0	54.0	35.0	14	27	19	27	EVL-S-14-G 1/2"
S	400	16	G 1/2"	43	24.5	55.0	36.5	14	27	24	30	EVL-S-16-G 1/2"
S	400	20	G 3/4"	48	26.5	65.0	44.5	16	32	27	36	EVL-S-20-G 3/4"
S	400	25	G 1"	54	30.0	73.0	50.0	18	41	36	46	EVL-S-25-G 1"
S	400	30	G 1 1/4"	62	35.5	78.5	55.0	20	50	41	50	EVL-S-30-G 1 1/4"
S	250	38	G 1 1/2"	72	41.0	89.0	63.0	22	55	50	60	EVL-S-38-G 1 1/2"

Fittings can be supplied with nuts with silver-plated threads to help to prevent galling, or can be supplied body only - no nut or cutting ring.

If you require silver-plated nuts, use suffix -SC. If you require body only, use suffix -OMD.

Eg. EVL-L-12-G 3/8"-SC, or EVL-L-12-G 3/8"-OMD

8



24° compression fittings to ISO 8434-1 / DIN 2354

Adjustable standpipe run tee with metric parallel male stud

BOOK INDEX

SECTION INDEX

to ISO 8434-1 / DIN 2353

L and S series

Form B sealing shoulder

The swivel female must be finally assembled with a 1/2 turn after torque increases.

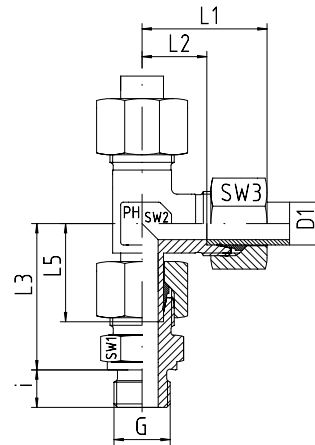

Series	Pressure PN	Tube O.D. D1	Thread G	Approx. Dimensions								Part code
				L1	L2	L3	L5	i	SW1	SW2	SW3	
L	315	6	M 10 x 1	27	12.0	34.5	26.0	8	14	12	14	EVL-L-06-M 10x1
L	315	8	M 12 x 1.5	29	14.0	37.5	27.5	12	17	12	17	EVL-L-08-M 12x1.5
L	315	10	M 14 x 1.5	30	15.0	40.0	29.0	12	19	14	19	EVL-L-10-M 14x1.5
L	315	12	M 16 x 1.5	32	17.0	42.0	29.5	12	22	17	22	EVL-L-12-M 16x1.5
L	315	15	M 18 x 1.5	36	21.0	46.0	32.5	12	24	19	27	EVL-L-15-M 18x1.5
L	315	18	M 22 x 1.5	40	23.5	50.0	35.5	14	27	24	32	EVL-L-18-M 22x1.5
L	160	22	M 26 x 1.5	44	27.5	55.0	38.5	16	32	27	36	EVL-L-22-M 26x1.5
L	160	28	M 33 x 2	47	30.5	61.0	43.5	18	41	36	41	EVL-L-28-M 33x2
L	160	35	M 42 x 2	56	34.5	71.5	54.0	20	50	41	50	EVL-L-35-M 42x2
L	160	42	M 48 x 2	63	40.0	75.0	56.0	22	55	50	60	EVL-L-42-M 48x2

Series	Pressure PN	Tube O.D. D1	Thread G	Approx. Dimensions								Part code
				L1	L2	L3	L5	i	SW1	SW2	SW3	
S	630	6	M 12 x 1.5	31	16.0	40.0	27.0	12	17	12	17	EVL-S-06-M 12x1.5
S	630	8	M 14 x 1.5	32	17.0	42.5	27.5	12	19	14	19	EVL-S-08-M 14x1.5
S	630	10	M 16 x 1.5	34	17.5	45.0	30.0	12	22	17	22	EVL-S-10-M 16x1.5
S	630	12	M 18 x 1.5	38	21.5	48.0	31.0	12	24	17	24	EVL-S-12-M 18x1.5
S	630	14	M 20 x 1.5	40	22.0	54.0	35.0	14	27	19	27	EVL-S-14-M 20x1.5
S	400	16	M 22 x 1.5	43	24.5	55.0	36.5	14	27	24	30	EVL-S-16-M 22x1.5
S	400	20	M 27 x 2	48	26.5	65.0	44.5	16	32	27	36	EVL-S-20-M 27x2
S	400	25	M 33 x 2	54	30.0	73.0	50.0	18	41	36	46	EVL-S-25-M 33x2
S	400	30	M 42 x 2	62	35.5	78.5	55.0	20	50	41	50	EVL-S-30-M 42x2
S	250	38	M 48 x 2	72	41.0	89.0	63.0	22	55	50	60	EVL-S-38-M 48x2

Fittings can be supplied with nuts with silver-plated threads to help to prevent galling, or can be supplied body only - no nut or cutting ring.

If you require silver-plated nuts, use suffix -SC. If you require body only, use suffix -OMD.

Eg. EVL-L-12-M 16x1.5-SC, EVL-L-12-M 16x1.5-OMD

Non-return valves

BOOK INDEX

SECTION INDEX

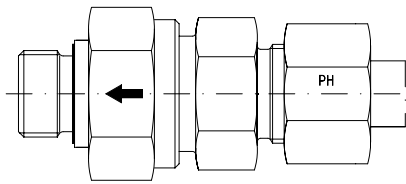

RZ

Flow towards male thread

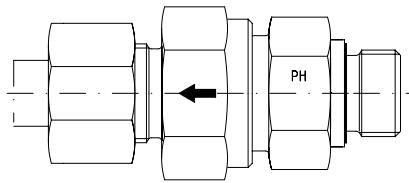

RV

Flow away from male thread

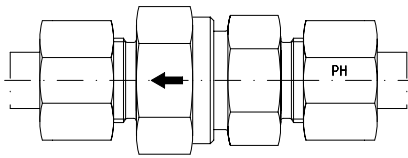

RD

Compression both ends

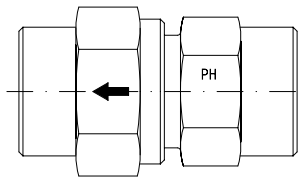

RD-I

BSP parallel female both ends

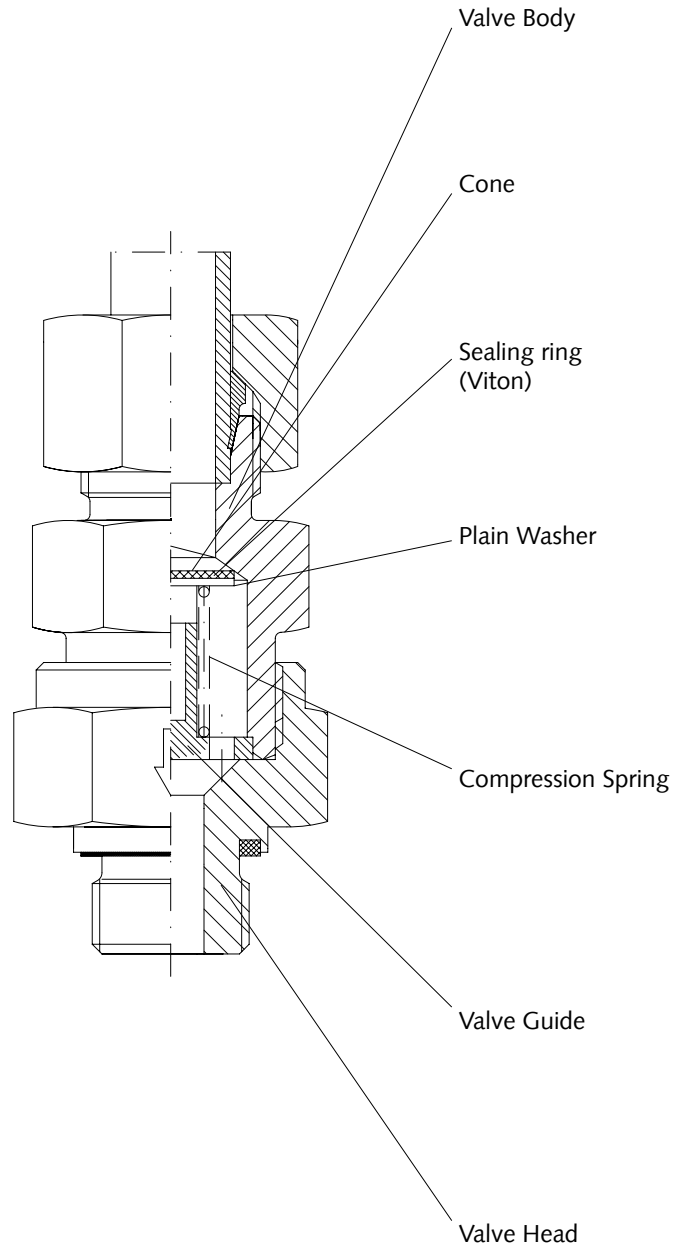

8

Important Data

Our needle valves are supplied with springs which open as standard at 1 bar. Other springs such as 0.2, 0.5, 2 and 3 bar are available.

These valves have a limited stroke, the flow is around 4-5 m/s. All valves are marked with flow direction and spring rating.

Material is 1.4571 (316Ti) stainless and has Viton seals (-20° C to +200° C). Opening pressure tolerance is +/- 20%.

Designed for use with hydraulic fluids.

In order to guarantee the suitability of the valves for applications other than hydraulic fluids, we need to know the medium, concentration, max working pressure including peak pressure, temperature and frequency of operation.



24° compression fittings to ISO 8434-1 / DIN 2354

Non-return valves – technical / pressure drop data

BOOK INDEX

SECTION INDEX

Tested with hydraulic oil

1 cm² / s = 100 cSt

1 bar opening pressure

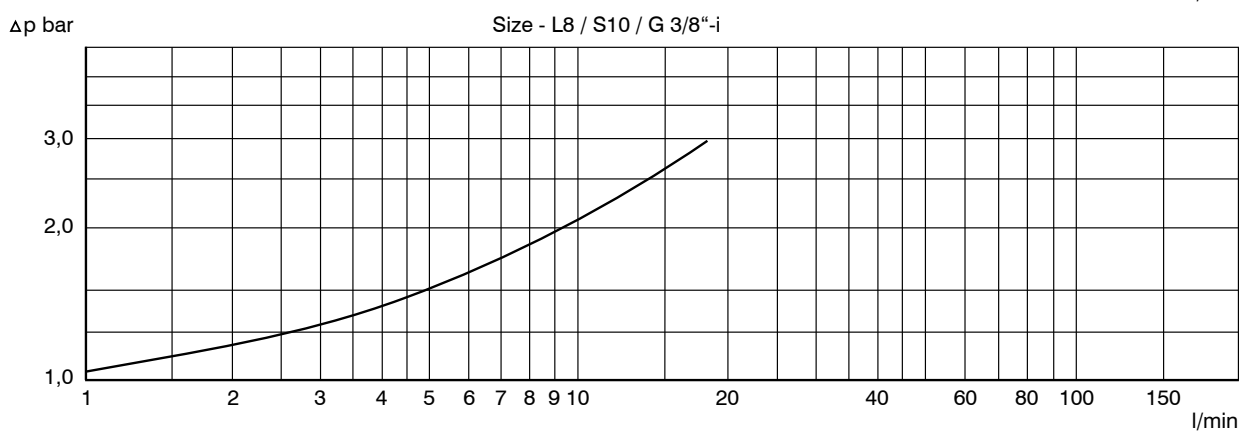
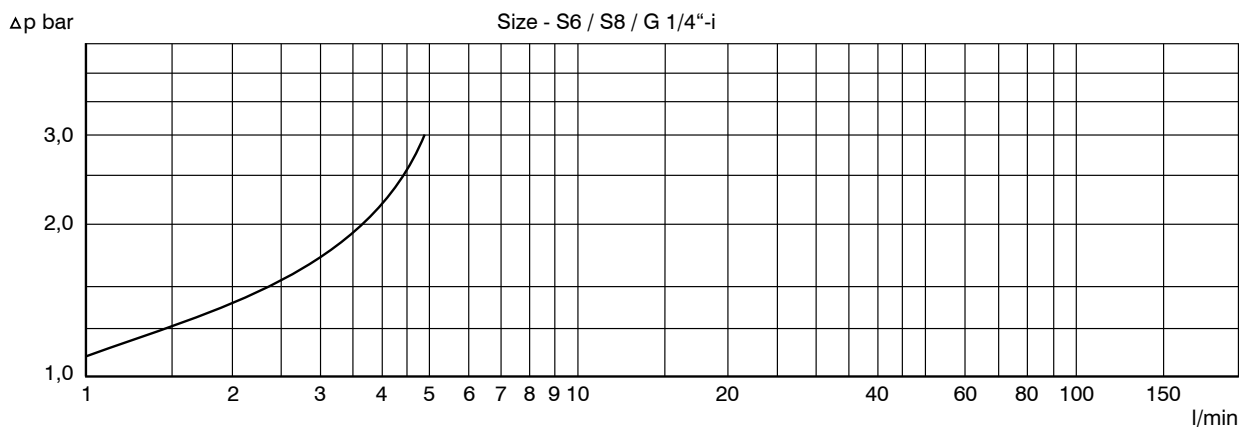
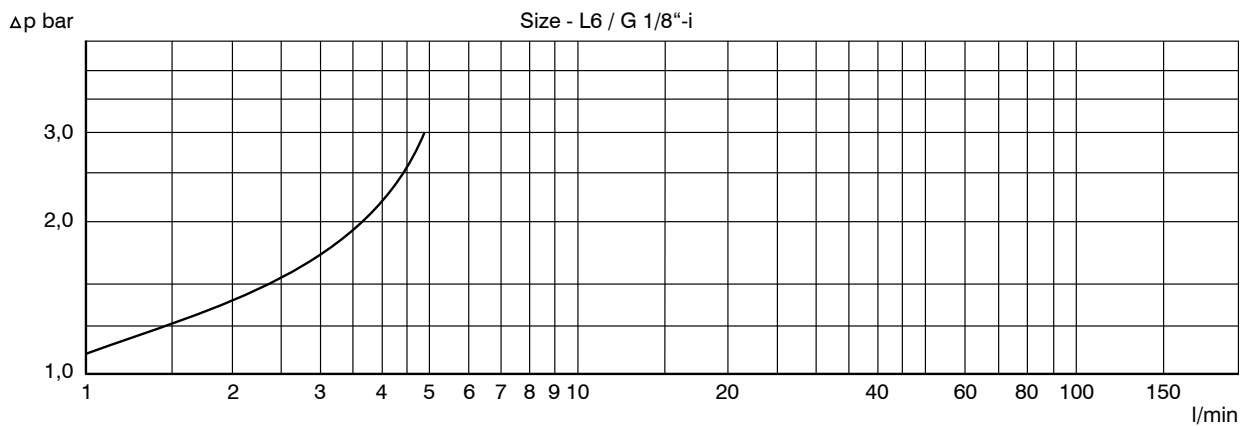



24° compression fittings to ISO 8434-1 / DIN 2354

Non-return valves – technical / pressure drop data

BOOK INDEX

SECTION INDEX

Tested with hydraulic oil

1 cm² / s = 100 cSt

1 bar opening pressure

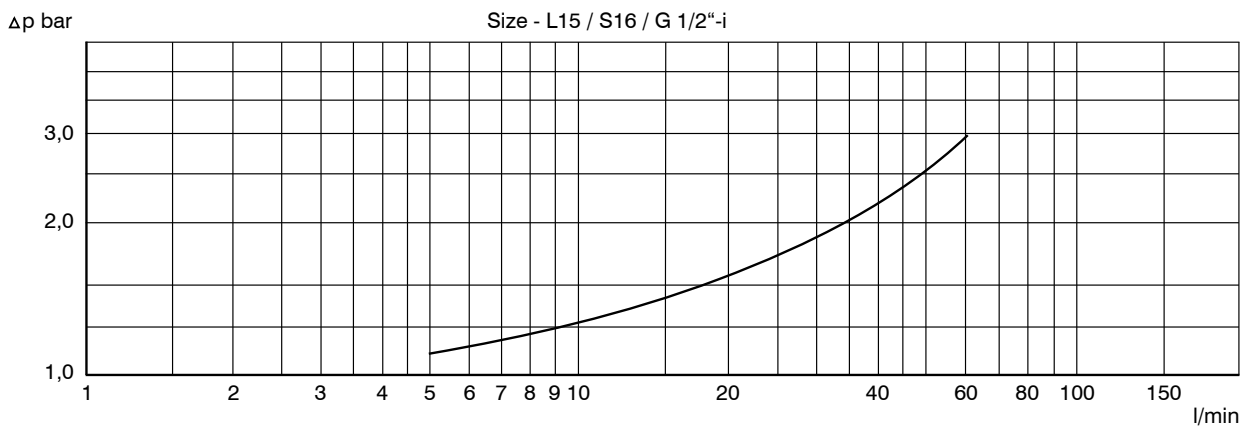
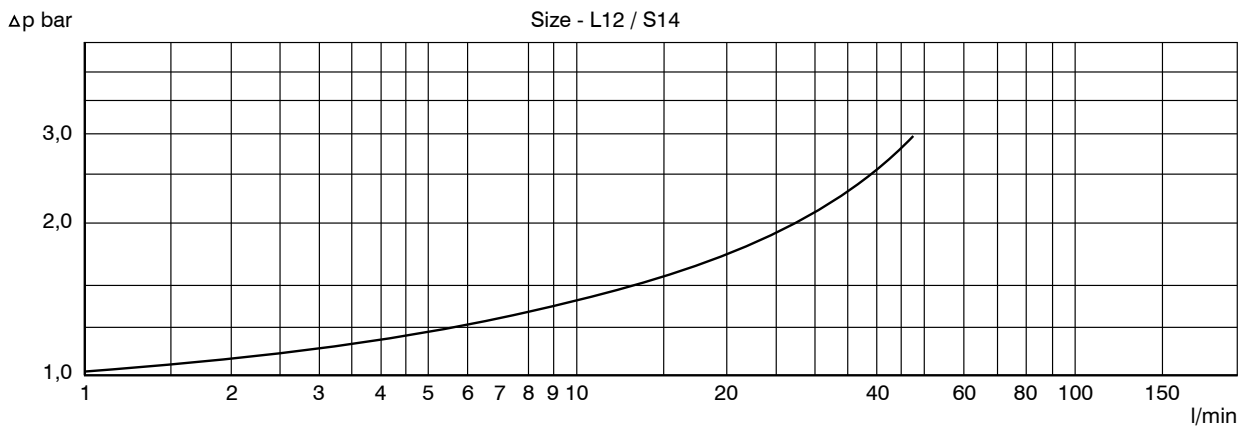
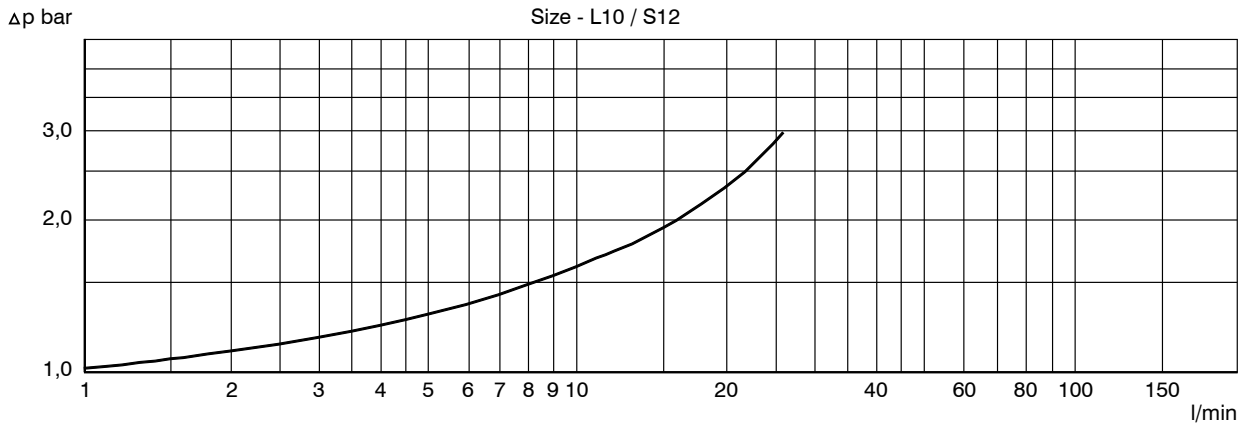



24° compression fittings to ISO 8434-1 / DIN 2354

Non-return valves – technical / pressure drop data

BOOK INDEX

SECTION INDEX

Tested with hydraulic oil

1 cm² / s = 100 cSt

1 bar opening pressure

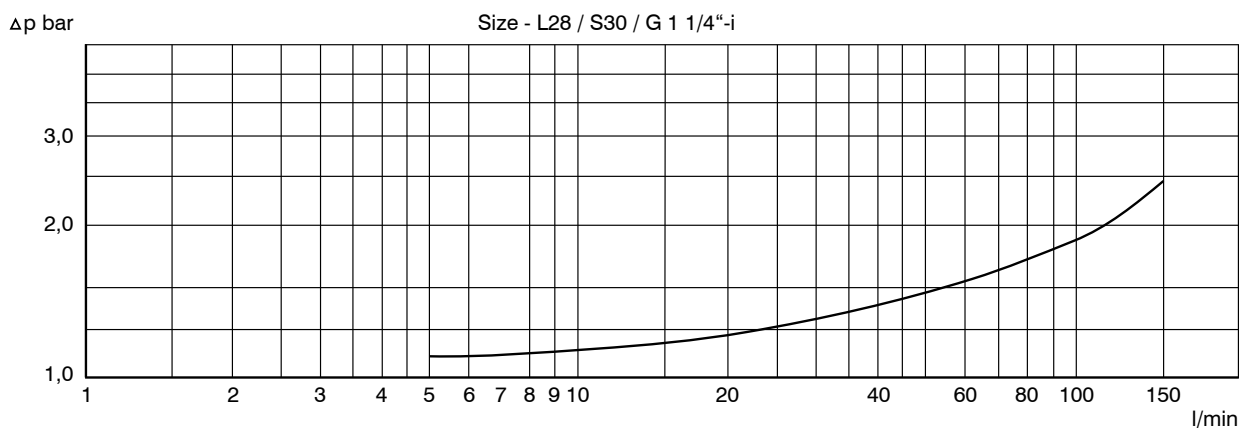
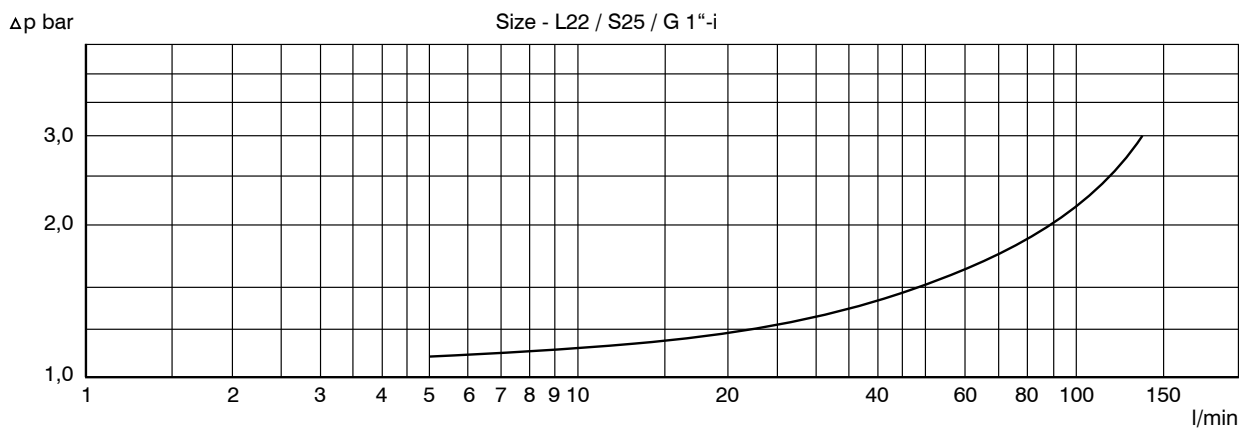
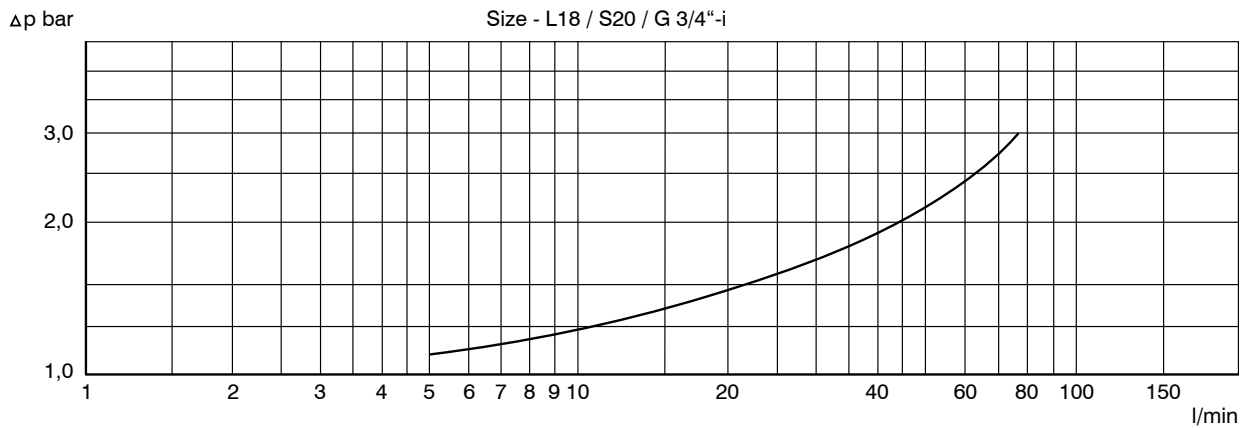



24° compression fittings to ISO 8434-1 / DIN 2354

Non-return valves – technical / pressure drop data

BOOK INDEX

SECTION INDEX

Tested with hydraulic oil

1 cm² / s = 100 cSt

1 bar opening pressure

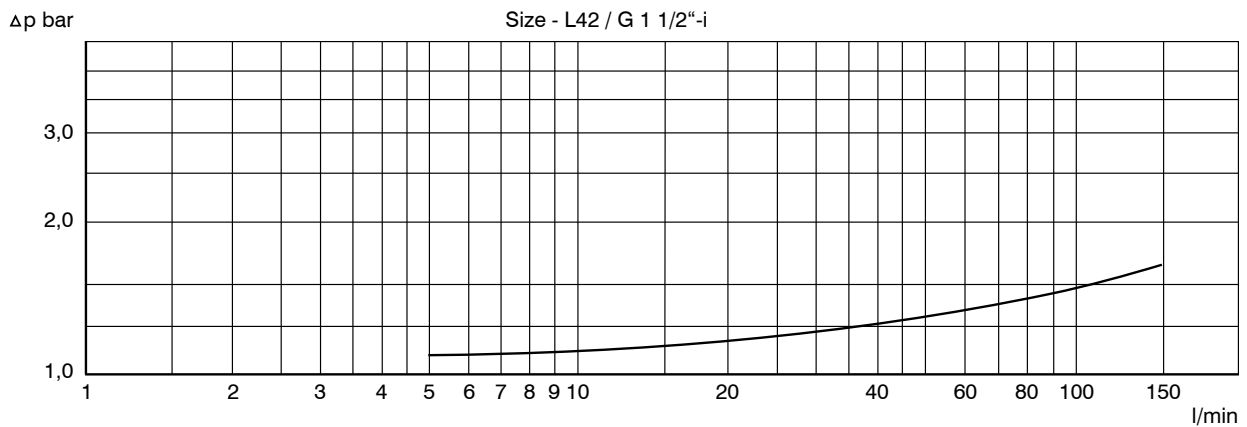
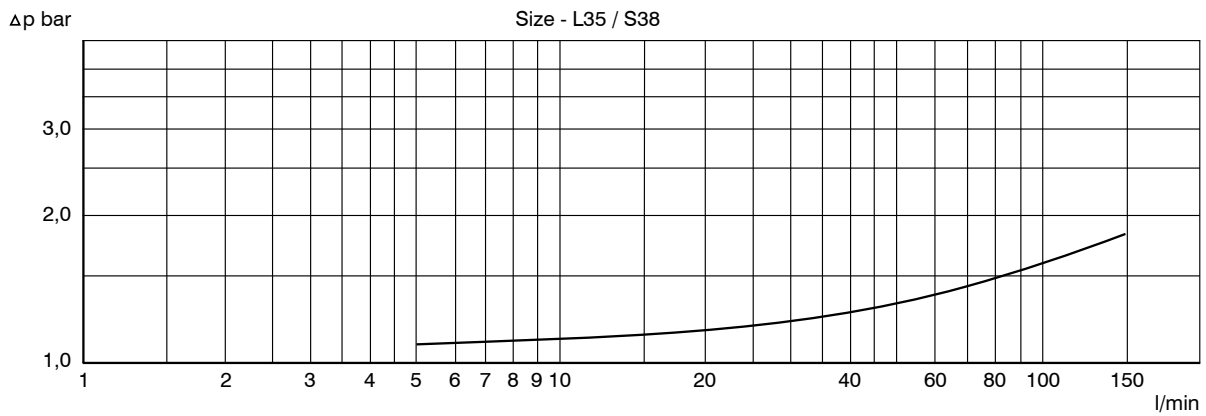



24° compression fittings to ISO 8434-1 / DIN 2354

Non-return valves – technical / pressure drop data

BOOK INDEX

SECTION INDEX

Tested with hydraulic oil

1 cm² / s = 100 cSt

1 bar opening pressure

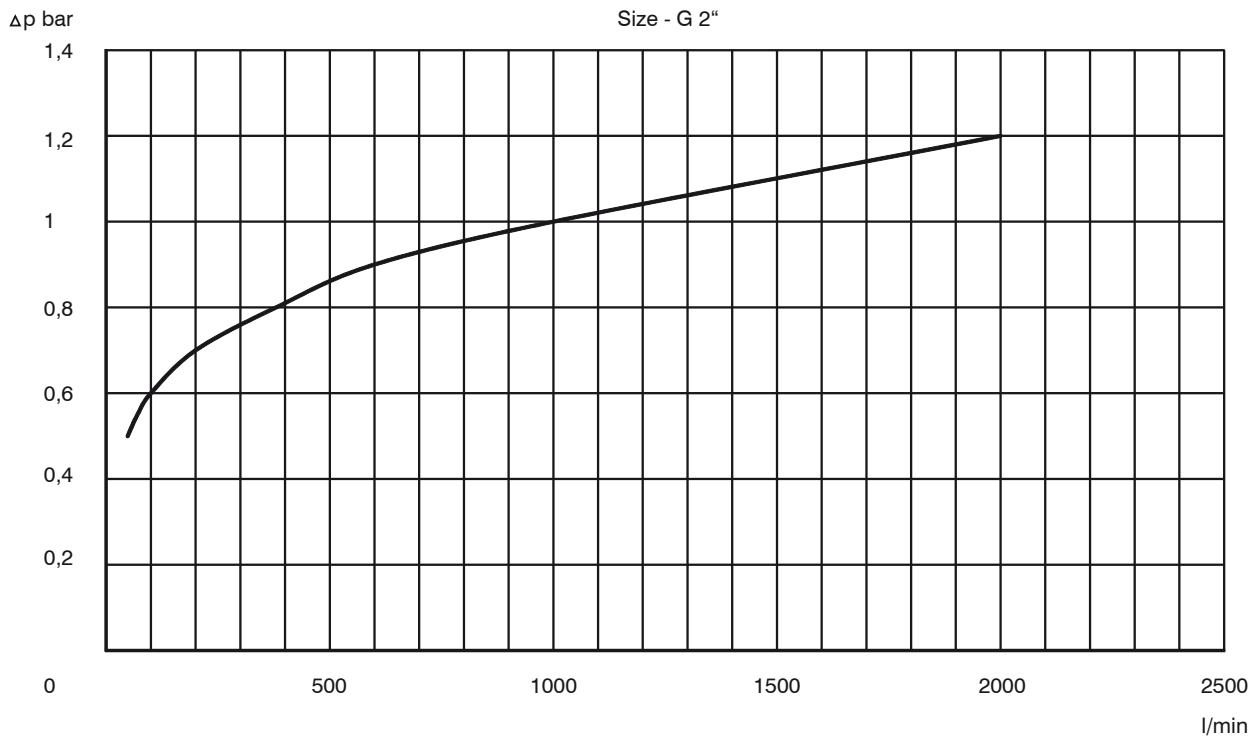

BSP parallel internal thread
NPT female internal thread

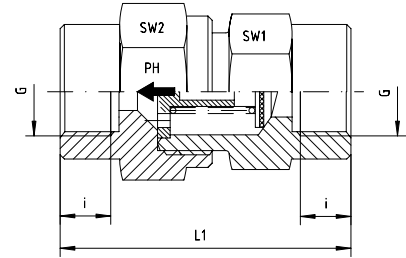

BSP female

Pressure PB	Thread G	Approx. Dimensions				Part code
		L1	i	SW1	SW2	
400	G 1/8" BSP	42.5	8.0	17	17	RD-I-G 1/8"
400	G 1/4" BSP	54.0	12.0	19	19	RD-I-G 1/4"
400	G 3/8" BSP	60.0	12.0	24	27	RD-I-G 3/8"
400	G 1/2" BSP	71.0	15.0	32	36	RD-I-G 1/2"
400	G 3/4" BSP	84.0	16.5	41	46	RD-I-G 3/4"
400	G 1" BSP	94.5	19.0	46	50	RD-I-G 1"
250	G 1 1/4" BSP	110.0	21.5	55	60	RD-I-G 1 1/4"
250	G 1 1/2" BSP	114.5	22.0	65	70	RD-I-G 1 1/2"
250	G 2" BSP	120.0	26.0	75	75	only 0.5 bar valve lift pressure RD-I-G 2"

NPT female

Pressure PB	Thread G	Approx. Dimensions				Part code
		L1	i	SW1	SW2	
400	1/8" NPT	42.5	11.6	17	17	RD-I-NPT-1/8"
400	1/4" NPT	57.5	16.4	19	19	RD-I-NPT-1/4"
400	3/8" NPT	63.5	17.4	24	27	RD-I-NPT-3/8"
400	1/2" NPT	78.0	22.6	32	36	RD-I-NPT-1/2"
400	3/4" NPT	84.5	23.1	41	46	RD-I-NPT-3/4"
400	1" NPT	101.0	27.8	46	50	RD-I-NPT-1"
250	1 1/4" NPT	110.0	28.3	55	60	RD-I-NPT-1 1/4"
250	1 1/2" NPT	117.5	28.3	65	70	RD-I-NPT-1 1/2"
250	2" NPT	120.0		75	75	only 0.5 bar valve lift pressure RD-I-NPT-2"

Non-return valve – compression to metric parallel male – flow towards thread

BOOK INDEX

SECTION INDEX

to ISO 8434-1 / DIN 2353

L and S series

Metric parallel male thread
with Viton elastomeric soft
seal

Flow towards male thread

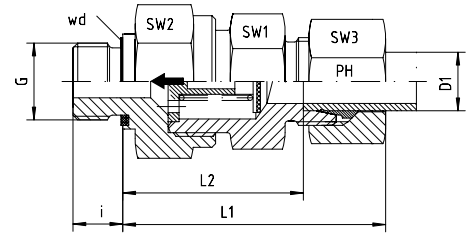

Series	Pressure PB	Tube O.D. D1	Thread G	Approx. Dimensions						Part code
				L1	L2	i	SW1	SW2	SW3	
L	250	6	M 10 x 1	41	26.5	8	17	17	14	RZ-L-06-M 10x1-wd
L	250	8	M 12 x 1.5	43	28.5	12	19	17	17	RZ-L-08-M 12x1.5-wd
L	250	10	M 14 x 1.5	53	38.5	12	24	22	19	RZ-L-10-M 14x1.5-wd
L	250	12	M 16 x 1.5	55	40.5	12	30	27	22	RZ-L-12-M 16x1.5-wd
L	250	15	M 18 x 1.5	58	42.5	12	30	27	27	RZ-L-15-M 18x1.5-wd
L	160	18	M 22 x 1.5	64	48.0	14	36	36	32	RZ-L-18-M 22x1.5-wd
L	160	22	M 26 x 1.5	72	56.0	16	46	41	36	RZ-L-22-M 26x1.5-wd
L	100	28	M 33 x 2	81	64.0	18	55	50	41	RZ-L-28-M 33x2-wd
L	100	35	M 42 x 2	92	70.0	20	60	60	50	RZ-L-35-M 42x2-wd
L	100	42	M 48 x 2	104	71.5	22	70	65	60	RZ-L-42-M 48x2-wd

Series	Pressure PB	Tube O.D. D1	Thread G	Approx. Dimensions						Part code
				L1	L2	i	SW1	SW2	SW3	
S	630	6	M 12 x 1.5	46	31.5	12	19	19	17	RZ-S-06-M 12x1.5-wd
S	630	8	M 14 x 1.5	46	31.5	12	22	19	19	RZ-S-08-M 14x1.5-wd
S	630	10	M 16 x 1.5	54	38.0	12	27	24	22	RZ-S-10-M 16x1.5-wd
S	630	12	M 18 x 1.5	57	41.0	12	30	27	24	RZ-S-12-M 18x1.5-wd
S	630	14	M 20 x 1.5	61	43.5	14	32	27	27	RZ-S-14-M 20x1.5-wd
S	400	16	M 22 x 1.5	64	46.0	14	36	32	30	RZ-S-16-M 22x1.5-wd
S	400	20	M 27 x 2	72	50.0	16	46	41	36	RZ-S-20-M 27x2-wd
S	400	25	M 33 x 2	79	54.5	18	50	46	46	RZ-S-25-M 33x2-wd
S	250	30	M 42 x 2	91	64.0	20	60	55	50	RZ-S-30-M 42x2-wd
S	250	38	M 48 x 2	102	71.5	22	70	65	60	RZ-S-38-M 48x2-wd

Non-return valve – compression to BSP parallel male – flow towards thread

BOOK INDEX

SECTION INDEX

to ISO 8434-1 / DIN 2353

L and S series

BSP parallel male thread
with Viton elastomeric soft
seal

Flow towards male thread

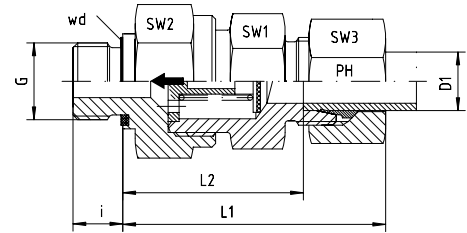

Series	Pressure PB	Tube O.D. D1	Thread G	Approx. Dimensions						Part code
				L1	L2	i	SW1	SW2	SW3	
L	250	6	G 1/8"	41	26.5	8	17	17	14	RZ-L-06-G 1/8"-wd
L	250	8	G 1/4"	43	28.5	12	19	17	17	RZ-L-08-G 1/4"-wd
L	250	10	G 1/4"	53	38.5	12	24	22	19	RZ-L-10-G 1/4"-wd
L	250	12	G 3/8"	55	40.5	12	30	27	22	RZ-L-12-G 3/8"-wd
L	250	15	G 1/2"	58	42.5	14	30	27	27	RZ-L-15-G 1/2"-wd
L	160	18	G 1/2"	64	48.0	14	36	36	32	RZ-L-18-G 1/2"-wd
L	160	22	G 3/4"	72	56.0	16	46	41	36	RZ-L-22-G 3/4"-wd
L	100	28	G 1"	81	64.0	18	55	50	41	RZ-L-28-G 1"-wd
L	100	35	G 1 1/4"	92	70.0	20	60	60	50	RZ-L-35-G 1 1/4"-wd
L	100	42	G 1 1/2"	104	71.5	22	70	65	60	RZ-L-42-G 1 1/2"-wd

Series	Pressure PB	Tube O.D. D1	Thread G	Approx. Dimensions						Part code
				L1	L2	i	SW1	SW2	SW3	
S	630	6	G 1/4"	46	31.5	12	19	19	17	RZ-S-06-G 1/4"-wd
S	630	8	G 1/4"	46	31.5	12	22	19	19	RZ-S-08-G 1/4"-wd
S	630	10	G 3/8"	54	38.0	12	27	24	22	RZ-S-10-G 3/8"-wd
S	630	12	G 3/8"	57	41.0	12	30	27	24	RZ-S-12-G 3/8"-wd
S	630	14	G 1/2"	61	43.5	14	32	27	27	RZ-S-14-G 1/2"-wd
S	400	16	G 1/2"	64	46.0	14	36	32	30	RZ-S-16-G 1/2"-wd
S	400	20	G 3/4"	72	50.0	16	46	41	36	RZ-S-20-G 3/4"-wd
S	400	25	G 1"	79	54.5	18	50	46	46	RZ-S-25-G 1"-wd
S	250	30	G 1 1/4"	91	64.0	20	60	55	50	RZ-S-30-G 1 1/4"-wd
S	250	38	G 1 1/2"	102	71.5	22	70	65	60	RZ-S-38-G 1 1/2"-wd

to ISO 8434-1 / DIN 2353

L and S series

Metric parallel male thread
with Viton elastomeric soft
seal

Flow away from male
thread

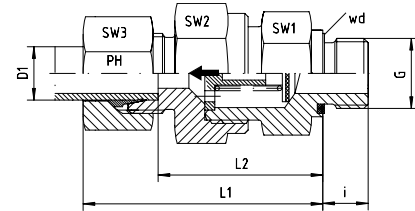

Series	Pressure PB	Tube O.D. D1	Thread G	Approx. Dimensions						Part code
				L1	L2	i	SW1	SW2	SW3	
L	250	6	M 10 x 1	43	28.0	8	17	17	14	RV-L-06-M 10x1-wd
L	250	8	M 12 x 1.5	44	29.0	12	17	19	17	RV-L-08-M 12x1.5-wd
L	250	10	M 14 x 1.5	53	38.5	12	22	24	19	RV-L-10-M 14x1.5-wd
L	250	12	M 16 x 1.5	57	42.5	12	27	30	22	RV-L-12-M 16x1.5-wd
L	250	15	M 18 x 1.5	61	45.5	12	27	30	27	RV-L-15-M 18x1.5-wd
L	160	18	M 22 x 1.5	66	50.0	14	36	36	32	RV-L-18-M 22x1.5-wd
L	160	22	M 26 x 1.5	71	55.0	16	41	46	36	RV-L-22-M 26x1.5-wd
L	100	28	M 33 x 2	80	63.0	18	50	55	41	RV-L-28-M 33x2-wd
L	100	35	M 42 x 2	91	69.0	20	60	60	50	RV-L-35-M 42x2-wd
L	100	42	M 48 x 2	104	71.5	22	65	70	60	RV-L-42-M 48x2-wd

Series	Pressure PB	Tube O.D. D1	Thread G	Approx. Dimensions						Part code
				L1	L2	i	SW1	SW2	SW3	
S	630	6	M 12 x 1.5	46	31.5	12	19	19	17	RV-S-06-M 12x1.5-wd
S	630	8	M 14 x 1.5	46	31.5	12	19	22	19	RV-S-08-M 14x1.5-wd
S	630	10	M 16 x 1.5	54	38.0	12	24	27	22	RV-S-10-M 16x1.5-wd
S	630	12	M 18 x 1.5	57	41.0	12	27	30	24	RV-S-12-M 18x1.5-wd
S	630	14	M 20 x 1.5	62	44.5	14	27	32	27	RV-S-14-M 20x1.5-wd
S	400	16	M 22 x 1.5	66	48.0	14	32	36	30	RV-S-16-M 22x1.5-wd
S	400	20	M 27 x 2	74	52.0	16	41	46	36	RV-S-20-M 27x2-wd
S	400	25	M 33 x 2	79	54.5	18	46	50	46	RV-S-25-M 33x2-wd
S	250	30	M 42 x 2	91	64.0	20	55	60	50	RV-S-30-M 42x2-wd
S	250	38	M 48 x 2	100	69.5	22	65	70	60	RV-S-38-M 48x2-wd



24° compression fittings to ISO 8434-1 / DIN 2354

Non-return valve – compression to BSP parallel male – flow away from thread

BOOK INDEX

SECTION INDEX

to ISO 8434-1 / DIN 2353

L and S series

BSP parallel male thread
with Viton elastomeric soft
seal

Flow away from male
thread

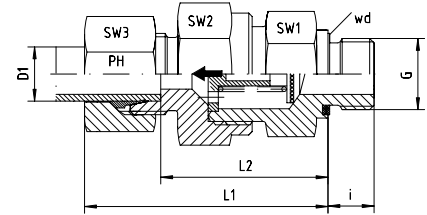

Series	Pressure PB	Tube O.D. D1	Thread G	Approx. Dimensions						Part code
				L1	L2	i	SW1	SW2	SW3	
L	250	6	G 1/8"	43	28.0	8	17	17	14	RV-L-06-G 1/8"-wd
L	250	8	G 1/4"	45	30.0	12	19	19	17	RV-L-08-G 1/4"-wd
L	250	10	G 1/4"	53	38.5	12	22	24	19	RV-L-10-G 1/4"-wd
L	250	12	G 3/8"	57	42.5	12	27	30	22	RV-L-12-G 3/8"-wd
L	250	15	G 1/2"	61	45.5	14	27	30	27	RV-L-15-G 1/2"-wd
L	160	18	G 1/2"	66	50.0	14	36	36	32	RV-L-18-G 1/2"-wd
L	160	22	G 3/4"	71	55.0	16	41	46	36	RV-L-22-G 3/4"-wd
L	100	28	G 1"	80	63.0	18	50	55	41	RV-L-28-G 1"-wd
L	100	35	G 1 1/4"	91	69.0	20	60	60	50	RV-L-35-G 1 1/4"-wd
L	100	42	G 1 1/2"	104	71.5	22	65	70	60	RV-L-42-G 1 1/2"-wd

Series	Pressure PB	Tube O.D. D1	Thread G	Approx. Dimensions						Part code
				L1	L2	i	SW1	SW2	SW3	
S	630	6	G 1/4"	46	31.5	12	19	19	17	RV-S-06-G 1/4"-wd
S	630	8	G 1/4"	46	31.5	12	19	22	19	RV-S-08-G 1/4"-wd
S	630	10	G 3/8"	54	38.0	12	24	27	22	RV-S-10-G 3/8"-wd
S	630	12	G 3/8"	57	41.0	12	27	30	24	RV-S-12-G 3/8"-wd
S	630	14	G 1/2"	62	44.5	14	27	32	27	RV-S-14-G 1/2"-wd
S	400	16	G 1/2"	66	48.0	14	32	36	30	RV-S-16-G 1/2"-wd
S	400	20	G 3/4"	74	52.0	16	41	46	36	RV-S-20-G 3/4"-wd
S	400	25	G 1"	79	54.5	18	46	50	46	RV-S-25-G 1"-wd
S	250	30	G 1 1/4"	91	64.0	20	55	60	50	RV-S-30-G 1 1/4"-wd
S	250	38	G 1 1/2"	100	69.5	22	65	70	60	RV-S-38-G 1 1/2"-wd

Non-return valve – compression both ends

BOOK INDEX

SECTION INDEX

to ISO 8434-1 / DIN 2353

L and S series

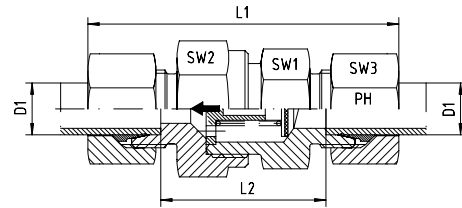

Series	Pressure PB	Tube O.D. D1	Approx. Dimensions					Part code
			L1	L2	SW1	SW2	SW3	
L	250	6	58	29.0	17	17	14	RD-L-06
L	250	8	59	30.0	17	19	17	RD-L-08
L	250	10	70	40.5	22	24	19	RD-L-10
L	250	12	73	43.5	27	30	22	RD-L-12
L	250	15	78	47.5	27	30	27	RD-L-15
L	160	18	84	51.5	36	36	32	RD-L-18
L	160	22	94	61.5	41	46	36	RD-L-22
L	100	28	103	69.5	50	55	41	RD-L-28
L	100	35	118	74.5	60	60	50	RD-L-35
L	100	42	122	74.0	65	70	60	RD-L-42

Series	Pressure PB	Tube O.D. D1	Approx. Dimensions					Part code
			L1	L2	SW1	SW2	SW3	
S	630	6	64	34.5	19	19	17	RD-S-06
S	630	8	64	34.5	19	22	19	RD-S-08
S	630	10	73	40.5	24	27	22	RD-S-10
S	630	12	75	42.5	27	30	24	RD-S-12
S	630	14	83	47.5	27	32	27	RD-S-14
S	400	16	87	50.5	32	36	30	RD-S-16
S	400	20	98	54.5	41	46	36	RD-S-20
S	400	25	107	58.5	46	50	46	RD-S-25
S	250	30	123	69.5	55	60	50	RD-S-30
S	250	38	140	75.5	65	70	60	RD-S-38

Adjustable standpipe reducer

BOOK INDEX

SECTION INDEX

to ISO 8434-1 / DIN 2353

S series

The swivel female must be finally assembled with a 1/2 turn after torque increases.

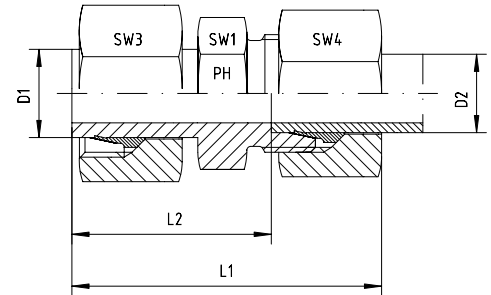
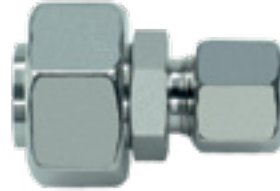

Series	Pressure PN	Tube O.D. D1	Tube O.D. D2	Approx. Dimensions					Part code
				L1	L2	SW1	SW3	SW4	
S	630	8	6	47.0	32.0	14	19	17	KOR-S-08/06
S	630	10	6	48.0	33.0	14	22	17	KOR-S-10/06
S	630	10	8	48.0	33.0	17	22	19	KOR-S-10/08
S	630	12	6	50.0	35.0	14	24	17	KOR-S-12/06
S	630	12	8	50.0	35.0	17	24	19	KOR-S-12/08
S	630	12	10	51.0	34.5	19	24	22	KOR-S-12/10
S	630	14	6	50.0	35.0	17	27	17	KOR-S-14/06
S	630	14	8	50.0	35.0	17	27	19	KOR-S-14/08
S	630	14	10	51.0	34.5	19	27	22	KOR-S-14/10
S	630	14	12	51.0	34.5	22	27	24	KOR-S-14/12
S	400	16	6	54.0	39.0	17	30	17	KOR-S-16/06
S	400	16	8	54.0	39.0	17	30	19	KOR-S-16/08
S	400	16	10	55.0	38.5	19	30	22	KOR-S-16/10
S	400	16	12	55.0	38.5	22	30	24	KOR-S-16/12
S	400	16	14	58.0	40.0	22	30	27	KOR-S-16/14
S	400	20	6	58.5	43.5	22	36	17	KOR-S-20/06
S	400	20	8	58.5	43.5	22	36	19	KOR-S-20/08
S	400	20	10	59.5	43.0	22	36	22	KOR-S-20/10
S	400	20	12	59.5	43.0	22	36	24	KOR-S-20/12
S	400	20	14	60.5	42.5	22	36	27	KOR-S-20/14
S	400	20	16	63.0	44.5	24	36	30	KOR-S-20/16
S	400	25	6	59.0	44.0	27	46	17	KOR-S-25/06
S	400	25	8	59.0	44.0	27	46	19	KOR-S-25/08
S	400	25	10	61.0	44.5	27	46	22	KOR-S-25/10
S	400	25	12	63.0	46.5	27	46	24	KOR-S-25/12
S	400	25	14	64.0	46.0	27	46	27	KOR-S-25/14
S	400	25	16	67.0	48.5	27	46	30	KOR-S-25/16
S	400	25	20	70.0	48.5	30	46	36	KOR-S-25/20
S	400	30	6	69.0	54.0	32	50	17	KOR-S-30/06
S	400	30	8	69.0	54.0	32	50	19	KOR-S-30/08
S	400	30	10	70.0	53.5	32	50	22	KOR-S-30/10
S	400	30	12	70.0	53.5	32	50	24	KOR-S-30/12
S	400	30	14	71.0	53.0	32	50	27	KOR-S-30/14
S	400	30	16	73.0	54.5	32	50	30	KOR-S-30/16
S	400	30	20	76.0	54.5	32	50	36	KOR-S-30/20
S	400	30	25	81.5	57.5	36	50	46	KOR-S-30/25
S	250	38	6	70.0	55.0	41	60	17	KOR-S-38/06
S	250	38	8	70.0	55.0	41	60	19	KOR-S-38/08
S	250	38	10	71.0	54.5	41	60	22	KOR-S-38/10
S	250	38	12	71.0	54.5	41	60	24	KOR-S-38/12
S	250	38	14	74.0	56.0	41	60	27	KOR-S-38/14
S	250	38	16	74.0	55.5	41	60	30	KOR-S-38/16
S	250	38	20	79.0	57.5	41	60	36	KOR-S-38/20
S	250	38	25	84.0	60.0	41	60	46	KOR-S-38/25
S	250	38	30	87.0	60.5	46	60	50	KOR-S-38/30

Adjustable standpipe reducer

BOOK INDEX

SECTION INDEX

to ISO 8434-1 / DIN 2353

LL and L series

The swivel female must be finally assembled with a 1/2 turn after torque increases.

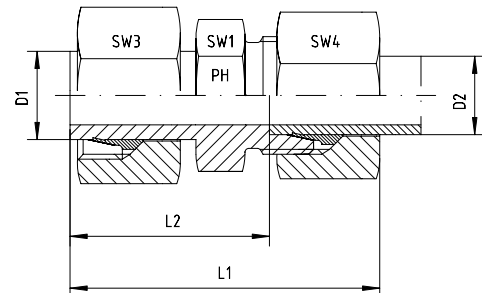

Series	Pressure PN	Tube O.D. D1	Tube O.D. D2	Approx. Dimensions					Part code
				L1	L2	SW1	SW3	SW4	
LL	100	6	4	35.0	23.0	10	12	10	KOR-LL-06/04
L	315	8	6	43.5	25.5	12	17	14	KOR-L-08/06
L	315	10	6	44.0	29.0	12	19	14	KOR-L-10/06
L	315	10	8	44.0	29.0	14	19	17	KOR-L-10/08
L	315	12	6	44.0	29.0	14	22	14	KOR-L-12/06
L	315	12	8	44.0	29.0	14	22	17	KOR-L-12/08
L	315	12	10	45.0	30.0	17	22	19	KOR-L-12/10
L	315	15	6	45.5	30.5	17	27	14	KOR-L-15/06
L	315	15	8	45.5	30.5	17	27	17	KOR-L-15/08
L	315	15	10	46.5	31.5	17	27	19	KOR-L-15/10
L	315	15	12	46.5	31.5	19	27	22	KOR-L-15/12
L	315	18	6	47.5	32.5	19	32	14	KOR-L-18/06
L	315	18	8	47.5	32.5	19	32	17	KOR-L-18/08
L	315	18	10	48.0	33.0	19	32	19	KOR-L-18/10
L	315	18	12	48.0	33.0	19	32	22	KOR-L-18/12
L	315	18	15	49.0	34.0	22	32	27	KOR-L-18/15
L	160	22	6	50.0	35.0	24	36	14	KOR-L-22/06
L	160	22	8	50.0	35.0	24	36	17	KOR-L-22/08
L	160	22	10	51.0	36.0	24	36	19	KOR-L-22/10
L	160	22	12	51.0	36.0	24	36	22	KOR-L-22/12
L	160	22	15	52.0	37.0	24	36	27	KOR-L-22/15
L	160	22	18	53.0	36.5	27	36	32	KOR-L-22/18
L	160	28	6	50.0	35.0	30	41	14	KOR-L-28/06
L	160	28	8	50.0	35.0	30	41	17	KOR-L-28/08
L	160	28	10	51.0	36.0	30	41	19	KOR-L-28/10
L	160	28	12	51.0	36.0	30	41	22	KOR-L-28/12
L	160	28	15	52.0	37.0	30	41	27	KOR-L-28/15
L	160	28	18	54.0	37.5	30	41	32	KOR-L-28/18
L	160	28	22	55.5	39.0	30	41	36	KOR-L-28/22
L	160	35	6	58.0	43.0	36	50	14	KOR-L-35/06
L	160	35	8	58.0	43.0	36	50	17	KOR-L-35/08
L	160	35	10	59.0	44.0	36	50	19	KOR-L-35/10
L	160	35	12	59.0	44.0	36	50	22	KOR-L-35/12
L	160	35	15	60.0	45.0	36	50	27	KOR-L-35/15
L	160	35	18	61.0	44.5	36	50	32	KOR-L-35/18
L	160	35	22	63.0	46.5	36	50	36	KOR-L-35/22
L	160	35	28	63.0	46.5	41	50	41	KOR-L-35/28
L	160	42	6	59.0	44.0	36	60	14	KOR-L-42/06
L	160	42	8	59.0	44.0	46	60	17	KOR-L-42/08
L	160	42	10	60.0	45.0	46	60	19	KOR-L-42/10
L	160	42	12	60.0	45.0	46	60	22	KOR-L-42/12
L	160	42	15	61.0	46.0	46	60	27	KOR-L-42/15
L	160	42	18	59.0	44.0	46	60	32	KOR-L-42/18
L	160	42	22	63.0	46.5	46	60	36	KOR-L-42/22
L	160	42	28	64.0	47.5	46	60	41	KOR-L-42/28
L	160	42	35	69.0	47.5	46	60	50	KOR-L-42/35

Hexagonal reducing bush – BSP parallel

BOOK INDEX

SECTION INDEX

Form A

Both threads BSP parallel
to DIN / ISO 228

Form B sealing shoulder

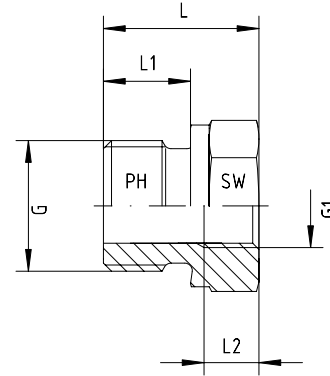

Pressure PN	Male Thread G	Female Thread G1	Approx. Dimensions				Form	Part code
			L	L1	L2	SW		
400	G 3/8"	G 1/8"	22.5	12.0	8.0	22	A	GRI-3/8" x 1/8"
400	G 1/2"	G 1/4"	24.0	14.0	12.0	27	A	GRI-1/2" x 1/4"
400	G 1/2"	G 1/8"	24.0	14.0	8.0	27	A	GRI-1/2" x 1/8"
400	G 3/4"	G 3/8"	26.0	16.0	13.0	32	A	GRI-3/4" x 3/8"
400	G 3/4"	G 1/4"	26.0	16.0	12.0	32	A	GRI-3/4" x 1/4"
400	G 3/4"	G 1/8"	26.0	16.0	8.0	32	A	GRI-3/4" x 1/8"
400	G 1"	G 1/2"	29.0	18.0	14.0	41	A	GRI-1" x 1/2"
400	G 1"	G 3/8"	29.0	18.0	12.0	41	A	GRI-1" x 3/8"
400	G 1"	G 1/4"	29.0	18.0	12.0	41	A	GRI-1" x 1/4"
250	G 1 1/4"	G 3/4"	32.0	20.0	16.0	50	A	GRI-1 1/4" x 3/4"
250	G 1 1/4"	G 1/2"	32.0	20.0	14.0	50	A	GRI-1 1/4" x 1/2"
250	G 1 1/4"	G 3/8"	32.0	20.0	17.0	50	A	GRI-1 1/4" x 3/8"
250	G 1 1/2"	G 1"	36.0	22.0	18.0	55	A	GRI-1 1/2" x 1"
250	G 1 1/2"	G 3/4"	36.0	22.0	16.0	55	A	GRI-1 1/2" x 3/4"
250	G 1 1/2"	G 1/2"	36.0	22.0	14.0	55	A	GRI-1 1/2" x 1/2"
250	G 2"	G 1 1/2"	42.0	22.5	18.5	70	A	GRI-2" x 1 1/2"
250	G 2"	G 1 1/4"	42.0	22.5	18.5	70	A	GRI-2" x 1 1/4"
250	G 2"	G 1"	42.0	22.5	18.5	70	A	GRI-2" x 1"
250	G 2"	G 3/4"	42.0	22.5	16.0	70	A	GRI-2" x 3/4"
250	G 2"	G 1/2"	41.5	22.5	16.0	70	A	GRI-2" x 1/2"

Hexagonal reducing bush – BSP parallel

BOOK INDEX

SECTION INDEX

Form B

Both threads BSP parallel
to DIN / ISO 228

Form B sealing shoulder

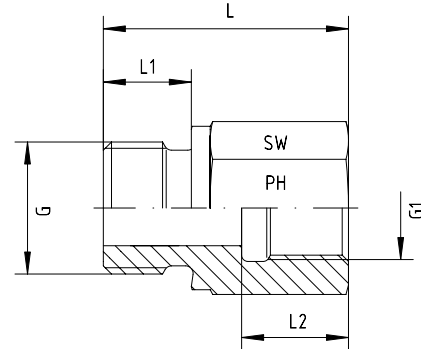
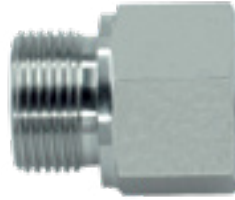

Pressure PN	Male Thread G	Female Thread G1	Approx. Dimensions				Form	Part code
			L	L1	L2	SW		
630	G 1/8"	G 3/8"	32.0	8.0	17.0	24	B	GRI-1/8" x 1/2"
630	G 1/8"	G 1/4"	31.0	8.0	17.0	19	B	GRI-1/8" x 3/8"
630	G 1/4"	G 3/4"	43.0	12.0	22.0	36	B	GRI-1/4" x 3/4"
630	G 1/4"	G 1/2"	40.0	12.0	20.0	27	B	GRI-1/4" x 1/2"
630	G 1/4"	G 3/8"	36.0	12.0	17.0	24	B	GRI-1/4" x 3/8"
630	G 1/4"	G 1/8"	28.0	12.0	12.0	19	B	GRI-1/4" x 1/8"
400	G 3/8"	G 1"	46.5	12.0	24.5	41	B	GRI-3/8" x 1"
400	G 3/8"	G 3/4"	44.0	12.0	22.0	36	B	GRI-3/8" x 3/4"
400	G 3/8"	G 1/2"	41.0	12.0	20.0	27	B	GRI-3/8" x 1/2"
400	G 3/8"	G 1/4"	36.0	12.0	17.0	22	B	GRI-3/8" x 1/4"
250	G 1/2"	G 1 1/4"	53.0	14.0	26.5	55	B	GRI-1/2" x 1 1/4"
400	G 1/2"	G 1"	49.0	14.0	24.5	41	B	GRI-1/2" x 1"
400	G 1/2"	G 3/4"	46.0	14.0	22.0	36	B	GRI-1/2" x 3/4"
400	G 1/2"	G 3/8"	36.0	14.0	17.0	27	B	GRI-1/2" x 3/8"
250	G 3/4"	G 1 1/2"	57.0	16.0	28.5	60	B	GRI-3/4" x 1 1/2"
250	G 3/4"	G 1 1/4"	55.0	16.0	26.5	55	B	GRI-3/4" x 1 1/4"
400	G 3/4"	G 1"	51.0	16.0	24.5	41	B	GRI-3/4" x 1"
400	G 3/4"	G 1/2"	41.0	16.0	20.0	32	B	GRI-3/4" x 1/2"
250	G 1"	G 1 1/2"	59.0	18.0	28.5	60	B	GRI-1" x 1 1/2"
250	G 1"	G 1 1/4"	57.0	18.0	26.5	55	B	GRI-1" x 1 1/4"
400	G 1"	G 3/4"	47.0	18.0	22.0	41	B	GRI-1" x 3/4"
250	G 1 1/4"	G 1 1/2"	60.0	20.0	28.5	60	B	GRI-1 1/4" x 1 1/2"
250	G 1 1/4"	G 1"	52.0	20.0	24.5	50	B	GRI-1 1/4" x 1"
250	G 1 1/2"	G 1 1/4"	58.0	22.0	26.5	55	B	GRI-1 1/2" x 1 1/4"

Hexagonal reducing bush – BSP parallel – with captive seal

BOOK INDEX

SECTION INDEX

Form A

Both threads BSP parallel
to DIN / ISO 228

Male thread with Viton
elastomeric soft seal

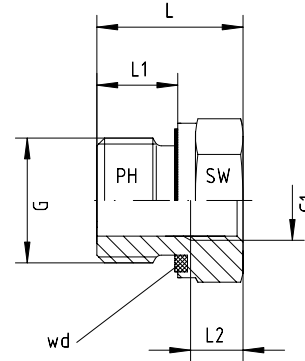
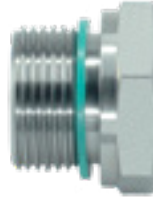

Pressure PN	Male Thread G	Female Thread G1	Approx. Dimensions				Form	Part code
			L	L1	L2	SW		
630	G 3/8"	G 1/8"	22.5	12.0	8.0	22	A	GRI-3/8"-wd x 1/8"
630	G 1/2"	G 1/4"	24.0	14.0	12.0	27	A	GRI-1/2"-wd x 1/4"
630	G 1/2"	G 1/8"	24.0	14.0	8.0	27	A	GRI-1/2"-wd x 1/8"
400	G 3/4"	G 3/8"	26.0	16.0	13.0	32	A	GRI-3/4"-wd x 3/8"
400	G 3/4"	G 1/4"	26.0	16.0	12.0	32	A	GRI-3/4"-wd x 1/4"
400	G 3/4"	G 1/8"	26.0	16.0	8.0	32	A	GRI-3/4"-wd x 1/8"
400	G 1"	G 1/2"	29.0	18.0	14.0	41	A	GRI-1"-wd x 1/2"
400	G 1"	G 3/8"	29.0	18.0	12.0	41	A	GRI-1"-wd x 3/8"
400	G 1"	G 1/4"	29.0	18.0	12.0	41	A	GRI-1"-wd x 1/4"
400	G 1 1/4"	G 3/4"	32.0	20.0	16.0	50	A	GRI-1 1/4"-wd x 3/4"
400	G 1 1/4"	G 1/2"	32.0	20.0	14.0	60	A	GRI-1 1/4"-wd x 1/2"
400	G 1 1/4"	G 3/8"	32.0	20.0	17.0	50	A	GRI-1 1/4"-wd x 3/8"
315	G 1 1/2"	G 1"	36.0	22.0	18.0	55	A	GRI-1 1/2"-wd x 1"
315	G 1 1/2"	G 3/4"	36.0	22.0	16.0	55	A	GRI-1 1/2"-wd x 3/4"
315	G 1 1/2"	G 1/2"	36.0	22.0	14.0	55	A	GRI-1 1/2"-wd x 1/2"
250	G 2"	G 1 1/2"	42.0	22.5	18.5	70	A	GRI-2"-wd x 1 1/2"
250	G 2"	G 1 1/4"	42.0	22.5	18.5	70	A	GRI-2"-wd x 1 1/4"
250	G 2"	G 1"	42.0	22.5	18.5	70	A	GRI-2"-wd x 1"
250	G 2"	G 3/4"	42.0	22.5	16.0	70	A	GRI-2"-wd x 3/4"
250	G 2"	G 1/2"	41.5	22.5	16.0	70	A	GRI-2"-wd x 1/2"

Hexagonal reducing bush – BSP parallel – with captive seal

BOOK INDEX

SECTION INDEX

Form B

Both threads BSP parallel
to DIN / ISO 228

Male thread with Viton
elastomeric soft seal

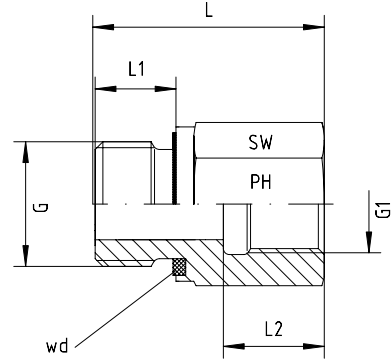
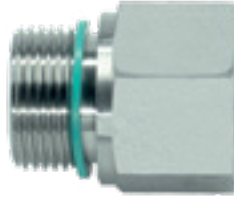

Pressure PN	Male Thread G	Female Thread G1	Approx. Dimensions				Form	Part code
			L	L1	L2	SW		
630	G 1/8"	G 3/8"	32.0	8.0	17.0	24	B	GRI-1/8"-wd x 1/2"
630	G 1/8"	G 1/4"	31.0	8.0	17.0	19	B	GRI-1/8"-wd x 3/8"
400	G 1/4"	G 1"	46.0	12.0	24.5	41	B	GRI-1/4"-wd x 1"
630	G 1/4"	G 3/4"	43.0	12.0	22.0	36	B	GRI-1/4"-wd x 3/4"
630	G 1/4"	G 1/2"	40.0	12.0	20.0	27	B	GRI-1/4"-wd x 1/2"
630	G 1/4"	G 3/8"	36.0	12.0	17.0	24	B	GRI-1/4"-wd x 3/8"
630	G 1/4"	G 1/8"	28.0	12.0	12.0	19	B	GRI-1/4"-wd x 1/8"
400	G 3/8"	G 1"	46.5	12.0	24.5	41	B	GRI-3/8"-wd x 1"
400	G 3/8"	G 3/4"	44.0	12.0	22.0	36	B	GRI-3/8"-wd x 3/4"
630	G 3/8"	G 1/2"	41.0	12.0	20.0	27	B	GRI-3/8"-wd x 1/2"
630	G 3/8"	G 1/4"	36.0	12.0	17.0	22	B	GRI-3/8"-wd x 1/4"
400	G 1/2"	G 1 1/4"	53.0	14.0	26.5	55	B	GRI-1/2"-wd x 1 1/4"
400	G 1/2"	G 1"	49.0	14.0	24.5	41	B	GRI-1/2"-wd x 1"
400	G 1/2"	G 3/4"	46.0	14.0	22.0	36	B	GRI-1/2"-wd x 3/4"
630	G 1/2"	G 3/8"	36.0	14.0	17.0	27	B	GRI-1/2"-wd x 3/8"
315	G 3/4"	G 1 1/2"	57.0	16.0	28.5	60	B	GRI-3/4"-wd x 1 1/2"
400	G 3/4"	G 1 1/4"	55.0	16.0	26.5	55	B	GRI-3/4"-wd x 1 1/4"
400	G 3/4"	G 1"	51.0	16.0	24.5	41	B	GRI-3/4"-wd x 1"
400	G 3/4"	G 1/2"	41.0	16.0	20.0	32	B	GRI-3/4"-wd x 1/2"
315	G 1"	G 1 1/2"	59.0	18.0	28.5	60	B	GRI-1"-wd x 1 1/2"
400	G 1"	G 1 1/4"	57.0	18.0	26.5	55	B	GRI-1"-wd x 1 1/4"
400	G 1"	G 3/4"	47.0	18.0	22.0	41	B	GRI-1"-wd x 3/4"
315	G 1 1/4"	G 1 1/2"	60.0	20.0	28.5	60	B	GRI-1 1/4"-wd x 1 1/2"
400	G 1 1/4"	G 1"	52.0	20.0	24.5	50	B	GRI-1 1/4"-wd x 1"
315	G 1 1/2"	G 1 1/4"	58.0	22.0	26.5	55	B	GRI-1 1/2"-wd x 1 1/4"

Compression blanking end

BOOK INDEX

SECTION INDEX

to ISO 8434-1 / DIN 2353

L and S series

Connection to W DIN 3861

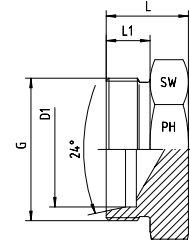

Series	Pressure PN	Tube O.D. D1	Thread G	Approx. Dimensions			Part code
				L	L1	SW	
L	500	6	M 12 x 1.5	14	10	12	XROV-L-06
L	500	8	M 14 x 1.5	15	10	14	XROV-L-08
L	500	10	M 16 x 1.5	16	11	17	XROV-L-10
L	400	12	M 18 x 1.5	17	11	19	XROV-L-12
L	400	15	M 22 x 1.5	18	12	24	XROV-L-15
L	400	18	M 26 x 1.5	19	12	27	XROV-L-18
L	250	22	M 30 x 2	21	14	32	XROV-L-22
L	250	28	M 36 x 2	22	14	41	XROV-L-28
L	250	35	M 45 x 2	25	16	46	XROV-L-35
L	250	42	M 52 x 2	27	16	55	XROV-L-42

Series	Pressure PN	Tube O.D. D1	Thread G	Approx. Dimensions			Part code
				L	L1	SW	
S	800	6	M 14 x 1.5	18	12	14	XROV-S-06
S	800	8	M 16 x 1.5	20	12	17	XROV-S-08
S	800	10	M 18 x 1.5	20	12	19	XROV-S-10
S	630	12	M 20 x 1.5	22	12	22	XROV-S-12
S	630	14	M 22 x 1.5	24	14	24	XROV-S-14
S	630	16	M 24 x 1.5	24	14	27	XROV-S-16
S	420	20	M 30 x 2	28	16	32	XROV-S-20
S	420	25	M 36 x 2	32	18	41	XROV-S-25
S	420	30	M 42 x 2	34	20	46	XROV-S-30
S	420	38	M 52 x 2	39	22	55	XROV-S-38

Compression blanking plug

BOOK INDEX

SECTION INDEX

to ISO 8434-1 / DIN 2353

L and S series

Connection to W DIN 3861

Supplied with NBR O-ring

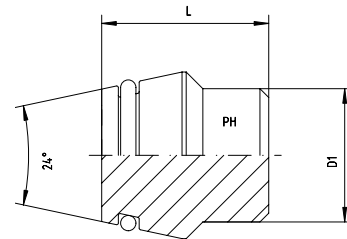

Series	Pressure PN	Tube O.D. D1	L	Part code
L	500	6	19.0	VKA-L-06
L	500	8	18.5	VKA-L-08
L	500	10	21.0	VKA-L-10
L	400	12	19.0	VKA-L-12
L	400	15	22.0	VKA-L-15
L	400	18	24.0	VKA-L-18
L	250	22	25.0	VKA-L-22
L	250	28	26.0	VKA-L-28
L	250	35	24.0	VKA-L-35
L	250	42	27.0	VKA-L-42

Series	Pressure PN	Tube O.D. D1	L	Part code
S	800	6	19.0	VKA-S-06
S	800	8	18.5	VKA-S-08
S	800	10	21.0	VKA-S-10
S	630	12	19.0	VKA-S-12
S	630	14	23.5	VKA-S-14
S	630	16	20.0	VKA-S-16
S	420	20	28.0	VKA-S-20
S	420	25	28.0	VKA-S-25
S	420	30	30.5	VKA-S-30
S	420	38	40.0	VKA-S-38

BSP and metric parallel allen key plugs

BOOK INDEX

SECTION INDEX

Round head, allen key socket.

Supplied with Viton elastomeric soft seal.

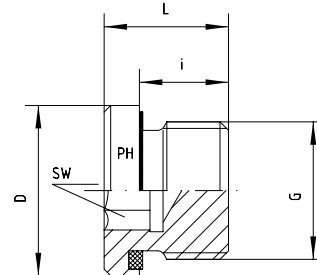

Pressure PN	Thread: Metric - Parallel G	Approx. Dimensions				Part code
		D	L	i	SW	
400	M 8 x 1	12	12.0	8	4	VST-M 8x1-wd
400	M 10 x 1	14	12.0	8	5	VST-M 10x1-wd
400	M 12 x 1.5	17	17.0	12	6	VST-M 12x1.5-wd
400	M 14 x 1.5	19	17.0	12	6	VST-M 14x1.5-wd
400	M 16 x 1.5	22	17.0	12	8	VST-M 16x1.5-wd
400	M 18 x 1.5	24	17.0	12	8	VST-M 18x1.5-wd
400	M 20 x 1.5	26	19.0	14	10	VST-M 20x1.5-wd
400	M 22 x 1.5	27	19.0	14	10	VST-M 22x1.5-wd
400	M 26 x 1.5	32	21.0	16	12	VST-M 26x1.5-wd
400	M 27 x 2	32	21.0	16	12	VST-M 27x2-wd
400	M 33 x 2	40	22.5	16	17	VST-M 33x2-wd
315	M 42 x 2	50	22.5	16	22	VST-M 42x2-wd
315	M 48 x 2	55	22.5	16	24	VST-M 48x2-wd

Pressure PN	Thread: Metric - Parallel G	Approx. Dimensions				Part code
		D	L	i	SW	
400	1/8"	14	12.0	8	5	VST-R 1/8"-wd
400	1/4"	19	17.0	12	6	VST-R 1/4"-wd
400	3/8"	22	17.0	12	8	VST-R 3/8"-wd
400	1/2"	27	19.0	14	10	VST-R 1/2"-wd
400	3/4"	32	21.0	16	12	VST-R 3/4"-wd
400	1"	40	22.5	16	17	VST-R 1"-wd
315	1 1/4"	50	22.5	16	22	VST-R 1 1/4"-wd
315	1 1/2"	55	22.5	16	24	VST-R 1 1/2"-wd
250	2"	70	34.0	24	32	VST-R 2"-wd

Tube reinforcing ring

BOOK INDEX

SECTION INDEX

Used to reinforce thin-walled tube to prevent tube collapse during fitting assembly.

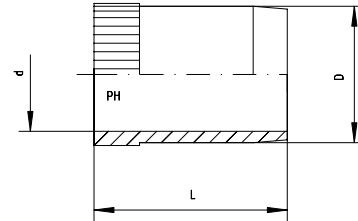

Tube Inside	Approx. Dimensions			Part code
	D	d	L	
4	3.8	2.5	17.0	VSHU-04
5	4.8	3.5	17.0	VSHU-05
6	5.8	4.5	14.0	VSHU-06
7	6.8	5.5	17.0	VSHU-07
8	7.8	6.5	15.5	VSHU-08
9	8.8	7.5	17.0	VSHU-09
10	9.8	8.5	15.5	VSHU-10
11	10.8	9.5	17.0	VSHU-11
12	11.8	10.5	17.0	VSHU-12
13	12.8	11.5	17.0	VSHU-13
14	13.8	12.0	17.0	VSHU-14
15	14.8	13.0	18.0	VSHU-15
16	15.8	14.0	18.0	VSHU-16
17	16.8	15.0	20.0	VSHU-17
18	17.8	16.0	20.0	VSHU-18
19	18.8	17.0	20.0	VSHU-19
20	19.8	18.0	20.0	VSHU-20
21	20.8	19.0	21.5	VSHU-21
22	21.8	20.0	24.0	VSHU-22
23	22.8	21.0	24.0	VSHU-23
24	23.8	22.0	23.5	VSHU-24
25	24.8	23.0	23.5	VSHU-25
26	25.8	24.0	23.5	VSHU-26
30	29.8	27.8	26.5	VSHU-30
31	30.8	28.0	26.5	VSHU-31
32	31.8	29.5	26.5	VSHU-32
33	32.8	30.0	26.5	VSHU-33
38	37.8	35.0	26.5	VSHU-38

Locknut

BOOK INDEX

SECTION INDEX

Metric thread -
for bulkhead fittings

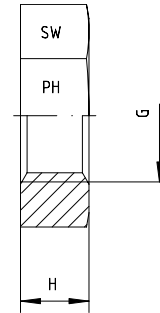

Thread G	H	SW	Part code
M 12 x 1.5 = 06-L	6	17	GM-12x1.5
M 14 x 1.5 = 08-L + 06-S	6	19	GM-14x1.5
M 16 x 1.5 = 10-L + 08-S	6	22	GM-16x1.5
M 18 x 1.5 = 12-L + 10-S	6	24	GM-18x1.5
M 20 x 1.5 = 12-S	6	27	GM-20x1.5
M 22 x 1.5 = 15-L + 14-S	7	30	GM-22x1.5
M 24 x 1.5 = 16-S	7	32	GM-24x1.5
M 26 x 1.5 = 18-L	8	36	GM-26x1.5
M 30 x 2 = 22-L + 20-S	8	41	GM-30x2
M 36 x 2 = 28-L + 25-S	9	46	GM-36x2
M 42 x 2 = 30-S	9	50	GM-42x2
M 45 x 2 = 35-L	9	55	GM-45x2
M 52 x 2 = 42-L + 38-S	10	65	GM-52x2

Internal coupling nut

BOOK INDEX

SECTION INDEX

Metric parallel thread

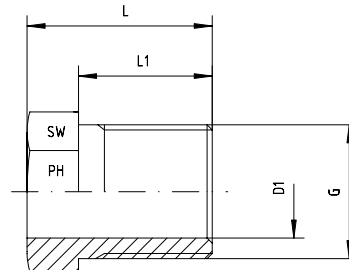

Series	Pressure PN	Tube O.D. D1 +Tol.	Thread G	Approx. Dimensions			DIN 3871	Part code	
				L	L1	SW			
LL	100	4	M 8 x 1	12	8.0	8	ALL 4		UWS-M 8x1
LL	100	6	M 10 x 1	13	9.0	10	ALL 6		UWS-M 10x1
LL	100	8	M 12 x 1	14	9.5	12	ALL 8		UWS-M 12x1
L	250	6	M 12 x 1.5	16	11.5	12	AL 6		UWS-M 12x1.5
L	250	8	M 14 x 1.5	16	11.5	14	AL 8		UWS-M 14x1.5
L	250	10	M 16 x 1.5	17	11.5	17	AL 10		UWS-M 16x1.5
L	250	12	M 18 x 1.5	18	12.0	19	AL 12		UWS-M 18x1.5

for WHV & THV banjo fittings
with wide port sealing faces

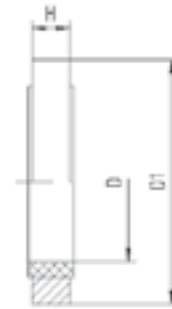

To use for: WHV / THV	Thread	Approx. Dimensions			Part code
		D	D1	H	
6 - LR KDR	G 1/8"	10.0	17.0	2.5	KDR-1/8"
8 - LR / 6 - SR KDR	G 1/4"	13.5	22.0	3.0	KDR-1/4"
10 - LR / 8 - SR KDR	G 1/4"	13.5	22.0	3.0	KDR-1/4"
12 - LR / 10 - SR KDR	G 3/8"	17.1	27.0	3.0	KDR-3/8"
12 - SR KDR	G 3/8"	17.1	27.0	3.0	KDR-3/8"
15 - LR / 14 - SR KDR	G 1/2"	21.4	32.0	4.5	KDR-1/2"
18 - LR / 16 - SR KDR	G 1/2"	21.4	32.0	4.5	KDR-1/2"
22 - LR / 20 - SR KDR	G 3/4"	26.8	41.0	3.5	KDR-3/4"
28 - LR / 25 - SR KDR	G 1"	33.5	46.0	3.5	KDR-1/33"
35 - LR / 30 - SR KDR	G 1 1/4"	42.4	57.0	3.5	KDR-1 1/4"/42
42 - LR / 38 - SR KDR	G 1 1/2"	48.4	64.0	3.5	KDR-1 1/2"/48
6 - LM KDR	M 10 x 1	10.3	17.0	2.5	KDR-10x1
8 - LM / 6 - SM KDR	M 12 x 1.5	12.3	22.0	3.0	KDR-12x1.5
10 - LM / 8 - SM KDR	M 14 x 1.5	14.3	22.5	3.0	KDR-14x1.5
12 - LM / 10 - SM KDR	M 16 x 1.5	16.4	27.0	3.0	KDR-16x1.5
15 - LM / 12 - SM KDR	M 18 x 1.5	18.4	29.0	3.0	KDR-18x1.5
14 - SM KDR	M 20 x 1.5	20.4	32.0	3.0	KDR-20x1.5
18 - LM / 16 - SM KDR	M 22 x 1.5	22.4	32.0	4.5	KDR-22x1.5
22 - LM	M 26 x 1.5	26.4	41.0	3.5	KDR-26x1.5
20 - SM KDR	M 27 x 2	27.4	41.0	3.5	KDR-27x2
28 - LM / 25 - SM KDR	M 33 x 2	33.5	46.0	3.5	KDR-33x2/1"
35 - LM / 30 - SM KDR	M 42 x 2	42.4	57.0	3.5	KDR-42x2/1 1/4"
42 - LM / 38 - SM KDR	M 48 x 2	48.4	64.0	3.5	KDR-48x2/1 1/2"

Self-centering 316 stainless bonded seals

NBR as standard, Viton upon request.

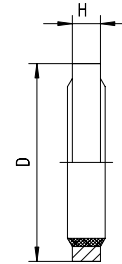

To use for:		Approx. Dimensions		Part code
Thread		D	H	
M 10 x 1	G 1/8"	16.0	2.5	DBS-G 1/8"
M 12 x 1.5		18.0	3.0	DBS-M 12
M 14 x 1.5	G 1/4"	20.0	3.0	DBS-G 1/4"
M 16 x 1.5	G 3/8"	24.0	3.0	DBS-G 3/8"
M 18 x 1.5		23.9	3.0	DBS-M 18
M 22 x 1.5	G 1/2"	30.0	4.5	DBS-G 1/2"
M 26 x 1.5		35.0	3.5	DBS-M 26
M 27 x 2	G 3/4"	38.0	3.5	DBS-G 3/4"
M 33 x 2	G 1"	42.0	3.5	DBS-G 1"
M 42 x 2	G 1 1/4"	49.9	3.5	DBS-G 1 1/4"
M 48 x 2	G 1 1/2"	60.0	3.5	DBS-G 1 1/2"
	G 2"			DBS-G 2"

for WHV & THV banjo fittings

Viton

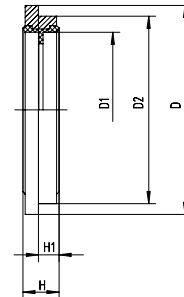

To use for: WHV / THV	Thread		Approx. Dimensions					Part code
			D	D1	D2	H	H1	
6 - LM / LR	M 10 x 1	G 1/8"	16.0	10.3	14.9	2.5	1.1	WDS-10
6 - SM / 8 - LM	M 12 x 1.5		18.0	12.3	17.0	3.0	1.6	WDS-12
6 - SR		G 1/4"	20.0	14.3	18.9	3.0	1.6	WDS-14
8 - LR / SR / SM	M 14 x 1.5	G 1/4"	20.0	14.3	18.9	3.0	1.6	WDS-14
10 - LM / LR	M 14 x 1.5	G 1/4"	20.0	14.3	18.9	3.0	1.6	WDS-14
10 - SR / SM	M 16 x 1.5	G 3/8"	24.0	17.0	21.9	3.0	2.1	WDS-16
12 - LR / LM /SR	M 16 x 1.5	G 3/8"	24.0	17.0	21.9	3.0	2.1	WDS-16
12 - SM / 15 - LM	M 18 x 1.5		23.9	18.3	23.9	3.0		WDS-18
15 - LR / 14 - SR		G 1/2"	30.0	22.3	26.9	4.5	2.6	WDS-22
16 - SR / 16 - SM	M 22 x 1.5	G 1/2"	30.0	22.3	26.9	4.5	2.6	WDS-22
18 - LR / 18 - LM	M 22 x 1.5	G 1/2"	30.0	22.3	26.9	4.5	2.6	WDS-22
22 - LM	M 26 x 1.5		35.0	26.3	31.9	3.5	2.6	WDS-26
20 - SR / 20 - SM	M 27 x 2	G 3/4"	38.0	27.3	32.9	3.5	2.6	WDS-27
22 - LR		G 3/4"	38.0	27.3	32.9	3.5	2.6	WDS-27
25 - SR / 25 - SM	M 33 x 2	G 1"	42.0	33.6	39.9	3.5	2.6	WDS-33
28 - LR / 28 - LM	M 33 x 2	G 1"	42.0	33.6	39.9	3.5	2.6	WDS-33
30 - SR / 30 - SM	M 42 x 2	G 1 1/4"	49.9	42.4	49.9	3.5		WDS-42
35 - LR / 35 - LM	M 42 x 2	G 1 1/4"	49.9	42.4	49.9	3.5		WDS-42
38 - SR / 38 - SM	M 48 x 2	G 1 1/2"	60.0	48.4	55.9	3.5	2.6	WDS-48
42 - LR / 42 - LM	M 48 x 2	G 1 1/2"	60.0	48.4	55.9	3.5	2.6	WDS-48

for WHV & THV banjo fittings
to seal external threads

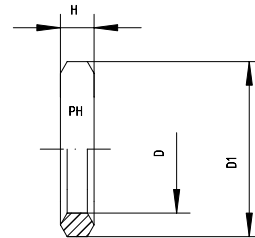

Thread	Approx. Dimensions			Part code
	D	D1	H	
G 1/8"	9.8	14	2.5	DKR-G 1/8"
G 1/4"	13.3	18	3.0	DKR-G 1/4"
G 3/8"	16.8	22	3.0	DKR-G 3/8"
G 1/2"	21.1	26	4.5	DKR-G 1/2"
G 3/4"	27.1	32	4.0	DKR-G 3/4"
G 1"	33.4	39	4.0	DKR-G 1"
G 1 1/4"	42.1	49	4.0	DKR-G 1 1/4"
G 1 1/2"	48.1	55	4.0	DKR-G 1 1/2"
M 10 x 1	10.0	14	2.5	DKR-M 10x1
M 12 x 1.5	12.1	17	3.0	DKR-M 12x1.5
M 14 x 1.5	14.1	19	3.0	DKR-M 14x1.5
M 16 x 1.5	16.1	21	3.0	DKR-M 16x1.5
M 18 x 1.5	18.1	23	3.0	DKR-M 18x1.5
M 20 x 1.5	20.1	25	3.0	DKR-M 20x1.5
M 22 x 1.5	22.1	27	3.0	DKR-M 22x1.5
M 26 x 1.5	26.1	31	3.0	DKR-M 26x1.5
M 27 x 2	27.1	32	4.0	DKR-M 27x2
M 33 x 2	33.1	39	4.0	DKR-M 33x2
M 42 x 2	42.1	49	4.0	DKR-M 42x2
M 48 x 2	48.1	55	4.0	DKR-M 48x2

sits inside pressure gauge
female threads

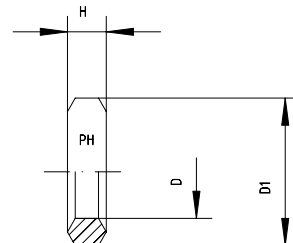

Thread	Approx. Dimensions			Part code
	D	D1	H	
G 1/4"	6	11.3	4.5	DKRi-G 1/4"
G 3/8"				DKRi-G 3/8"
G 1/2"	12	18.5	5.0	DKRi-G 1/2"
M 18 x 1.5				DKRi-M 18x1.5
M 20 x 1.5	12	17.5	5.0	DKRi-M 20x1.5

To DIN 3869
FPM (Viton)
-20°C to +200°C

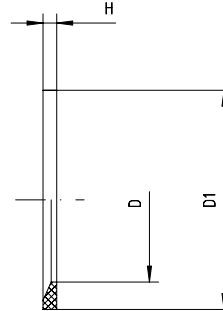

Thread		Approx. Dimensions			Part code
		D	D1	H	
M 8 x 1		6.5	9.9	1.0	WD-8x1
M 10 x 1	R 1/8"	8.4	11.9	1.0	WD-10x1/1/8"
M 12 x 1.5		9.8	14.4	1.5	WD-12x1.5
M 14 x 1.5	R 1/4"	11.6	16.5	1.5	WD-14x1.5/1/4"
M 16 x 1.5		13.8	18.9	1.5	WD-16x1.5
	R 3/8"	14.7	18.9	1.5	WD-3/8"
M 18 x 1.5		15.7	20.9	1.5	WD-18x1.5
M 20 x 1.5		17.8	22.9	1.5	WD-20x1.5
	R 1/2"	18.5	23.9	1.5	WD-1/2"
M 22 x 1.5		19.6	24.3	1.5	WD-22x1.5
M 26 x 1.5	R 3/4"	23.9	29.2	1.5	WD-26x1.5/3/4"
M 27 x 2	R 3/4"	23.9	29.2	1.5	WD-27x2/3/4"
M 33 x 2	R 1"	29.7	35.7	2.0	WD-33x2/1"
M 42 x 2	R 1 1/4"	38.8	45.8	2.0	WD-42x2/1 1/4"
M 48 x 2	R 1 1/2"	44.7	50.7	2.0	WD-48x2/1 1/2"



24° compression fittings to ISO 8434-1 / DIN 2354

SAE flange seals

BOOK INDEX

SECTION INDEX

Material – Polyurethane
-40°C to +100°C
for SAE flanges to SAE J518 / ISO 6162
3000 and 6000 psi

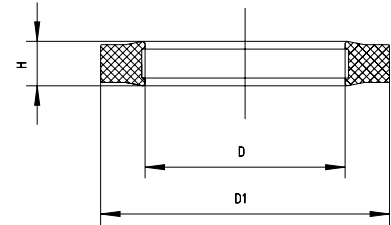

Flange Dimensions 3000 + 6000 P.S.I.	Pressure PN	Approx. Dimensions			Part code
		D	D1	H	
1/2"	420	17.0	25.4	3.5	PU-1/2"
3/4"	420	23.4	31.8	3.5	PU-3/4"
1"	420	31.3	39.7	3.5	PU-1"
1 1/4"	420	36.1	44.5	3.5	PU-1 1/4"
1 1/2"	420	45.4	53.8	3.5	PU-1 1/2"
2"	420	55.0	63.4	3.5	PU-2"

Double bite compression cutting rings – “Olives”

BOOK INDEX

SECTION INDEX

Made from heat-hardened stainless steel

LL, L and S series

LL series are only single-bite

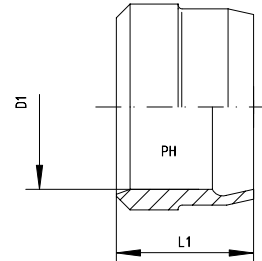

Tube O.D. D1	L1	DN 3861	Part code
4	6.0	ALL 4	SR-LL-04/1 K
6	7.0	ALL 6	SR-LL-06/1 K
8	7.0	ALL 8	SR-LL-08/1 K

Tube O.D. D1	L1	DN 3861	Part code
6	9.0	BL 6	SR-L-06/2 K
8	9.0	BL 8	SR-L-08/2 K
10	9.5	BL 10	SR-L-10/2 K
12	10.0	BL 12	SR-L-12/2 K
15	10.0	BL 15	SR-L-15/2 K
18	10.0	BL 18	SR-L-18/2 K
22	11.0	BL 22	SR-L-22/2 K
28	11.0	BL 28	SR-L-28/2 K
35	13.5	BL 35	SR-L-35/2 K
42	13.5	BL 42	SR-L-42/2 K

Tube O.D. D1	L1	DN 3861	Part code
6	9.0	BS 6	SR-S-06/2 K
8	9.0	BS 8	SR-S-08/2 K
10	9.5	BS 10	SR-S-10/2 K
12	10.0	BS 12	SR-S-12/2 K
14	9.5	BS 14	SR-S-14/2 K
16	10.0	BS 16	SR-S-16/2 K
20	11.5	BS 20	SR-S-20/2 K
25	12.5	BS 25	SR-S-25/2 K
30	12.5	BS 30	SR-S-30/2 K
38	13.5	BS 38	SR-S-38/2 K

Hardened cutting rings with
Viton elastomeric soft seal.

L and S series

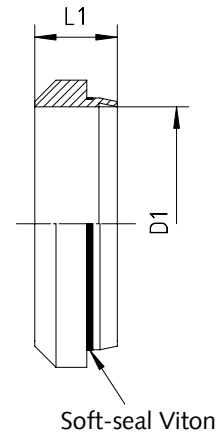

Tube O.D. D1	L1	Pressure PN	Part code
6	8.8	315	ES4-L-06-wd
8	8.8	315	ES4-L-08-wd
10	9.8	315	ES4-L-10-wd
12	9.8	315	ES4-L-12-wd
15	10.2	315	ES4-L-15-wd
18	10.2	315	ES4-L-18-wd
22	11.5	160	ES4-L-22-wd
28	11.5	160	ES4-L-28-wd
35	13.5	160	ES4-L-35-wd
42	13.5	160	ES4-L-42-wd

Tube O.D. D1	L1	Pressure PN	Part code
6	8.8	630	ES4-S-06-wd
8	8.8	630	ES4-S-08-wd
10	9.8	630	ES4-S-10-wd
12	9.8	630	ES4-S-12-wd
14	10.2	630	ES4-S-14-wd
16	10.2	400	ES4-S-16-wd
20	12.5	400	ES4-S-20-wd
25	12.5	400	ES4-S-25-wd
30	13.5	400	ES4-S-30-wd
38	13.5	315	ES4-S-38-wd

Nut

BOOK INDEX

SECTION INDEX

to DIN 3870 + DIN EN ISO 8434-1
for compression connections

LL, L and S series

For nuts with silver-plated threads add
-SC to the part code, eg. UWM-L-12-SC

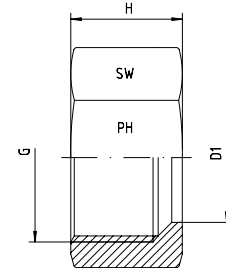

Tube O.D. D1	Thread G	Approx. Dimensions		DIN 3861		Part code
		SW	H			
4	M 8 x 1	10	11.0	ALL 4		UWM-LL-04
6	M 10 x 1	12	12.0	ALL 6		UWM-LL-06
8	M 12 x 1	14	12.5	ALL 8		UWM-LL-08

Tube O.D. D1	Thread G	Approx. Dimensions		ISO 8434-1	Part code
		SW	H		
6	M 12 x 1.5	14	14.5	N-L 6	UWM-L-06
8	M 14 x 1.5	17	14.5	N-L 8	UWM-L-08
10	M 16 x 1.5	19	15.5	N-L 10	UWM-L-10
12	M 18 x 1.5	22	15.5	N-L 12	UWM-L-12
15	M 22 x 1.5	27	17.0	N-L 15	UWM-L-15
18	M 26 x 1.5	32	18.0	N-L 18	UWM-L-18
22	M 30 x 2	36	20.0	N-L 22	UWM-L-22
28	M 36 x 2	41	21.0	N-L 28	UWM-L-28
35	M 45 x 2	50	24.0	N-L 35	UWM-L-35
42	M 52 x 2	60	24.0	N-L 42	UWM-L-42

Tube O.D. D1	Thread G	Approx. Dimensions		ISO 8434-1	Part code
		SW	H		
6	M 14 x 1.5	17	16.5	N-S 6	UWM-S-06
8	M 16 x 1.5	19	16.5	N-S 8	UWM-S-08
10	M 18 x 1.5	22	17.5	N-S 10	UWM-S-10
12	M 20 x 1.5	24	17.5	N-S 12	UWM-S-12
14	M 22 x 1.5	27	20.5	N-S 14	UWM-S-14
16	M 24 x 1.5	30	20.5	N-S 16	UWM-S-16
20	M 30 x 2	36	24.0	N-S 20	UWM-S-20
25	M 36 x 2	46	27.0	N-S 25	UWM-S-25
30	M 42 x 2	50	29.0	N-S 30	UWM-S-30
38	M 52 x 2	60	32.5	N-S 38	UWM-S-38